



Designation: **F1566—09 F1566 – 14**

Standard Test Methods for Evaluation of Innersprings, Boxsprings, Mattresses or Mattress Sets¹

This standard is issued under the fixed designation F1566; the number immediately following the designation indicates the year of original adoption or, in the case of revision, the year of last revision. A number in parentheses indicates the year of last reapproval. A superscript epsilon (ϵ) indicates an editorial change since the last revision or reapproval.

1. Scope

1.1 These test methods cover recognized methods for testing mattress innersprings, boxsprings, and finished mattresses or mattress sets, or both, to ensure uniformity of results.

1.2 These test methods are applicable to un-upholstered mattress core units including but not limited to innersprings, air chambers, and foam cores, un-upholstered foundations including but not limited to boxspring and build up foundations, finished foundations and mattress constructions. Data developed is for comparative analysis with no pass/fail criteria applicable.

1.3 The durability test (Section 7), impact test (Section 8) and firmness retention test/surface deformation (Section 9) require upholstered samples. Firmness testing may be ran on un-upholstered components, innerspring units and flexible boxsprings (6.1 through 6.4), or finished mattresses or mattress sets (6.5 through 6.8). A standardized upholstery package is specified if evaluating a mattress core or un-upholstered foundation. These test methods are intended to be used on newly manufactured products..

1.4 The values stated in SI units are to be regarded as standard. The values in parentheses are for information only.

1.5 *This standard does not purport to address all of the safety concerns, if any, associated with its use. It is the responsibility of the user of this standard to establish appropriate safety and health practices and determine the applicability of regulatory limitations prior to use.*

2. Referenced Documents

2.1 *ASTM Standards:*²

E4 Practices for Force Verification of Testing Machines

3. Terminology

3.1 *Definitions:*

3.1.1 *boxspring unit, n*—foundation for the mattress consisting of wire spring elements mounted on a frame.

3.1.2 *boxspring, upholstered, n*—foundation for the mattress consisting of wire spring elements mounted on a frame, generally upholstered and covered on top and sides with ticking, and bottom with a dust cover.

3.1.3 *foundation, n*—support base for a finished mattress generally upholstered and covered on top and sides with ticking, and bottom with a dust cover.

3.1.4 *innerspring unit, n*—interconnection of wire spring elements other than mounting on a frame that forms a single unit that can be incorporated into a mattress.

3.1.5 *mattress, innerspring, n*—any mattress containing an innerspring unit.

3.1.6 *posturized innerspring, n*—innerspring assembly having a varying coil density or varying wire gauge.

3.1.7 *mattress, n*—finished, assembled mattress core with upholstery package and cover.

3.1.8 *mattress core, n*—innermost support core of a mattress upon which upholstery is affixed.

3.1.9 *mattress set, n*—finished mattress and foundation combination.

¹ These test methods are under the jurisdiction of ASTM Committee F15 on Consumer Products and are the direct responsibility of Subcommittee F15.32 on Innersprings and Boxsprings.

Current edition approved Dec. 1, 2009; Nov. 15, 2014. Published January 2010; November 2014. Originally approved in 1994. Last previous edition approved in 2008; 2009 as F1566—08; F1566—09. DOI: 10.1520/F1566-09; 10.1520/F1566-14.

² For referenced ASTM standards, visit the ASTM website, www.astm.org, or contact ASTM Customer Service at service@astm.org. For *Annual Book of ASTM Standards* volume information, refer to the standard's Document Summary page on the ASTM website.

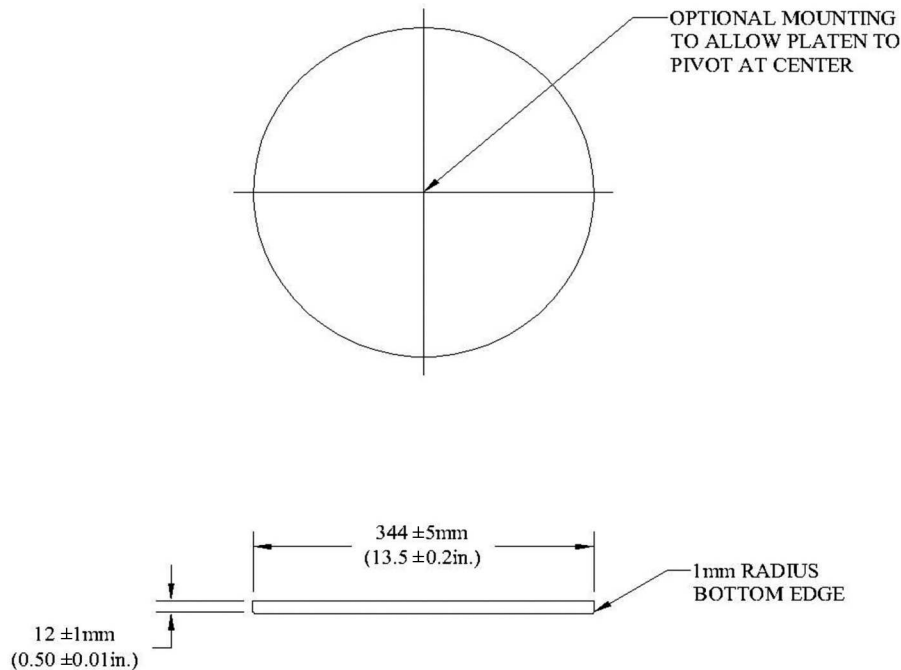

FIG. 1 Firmness Platen

3.1.10 *upholstery, n*—combination of materials designed to cover and add support or comfort, or both, to a mattress core.

4. Significance and Use

4.1 Two separate test methods are outlined for use in evaluation of (1) mattress components, innersprings and boxsprings and (2) mattresses and mattress sets.

4.2 Component innerspring and boxspring test methods include measurements of firmness, firmness retention, durability, and effect of impact.

4.3 Mattress and mattress set test methods include measurements of firmness, firmness retention, durability, effect of impact, and height change.

4.4 One or more of the test methods shall be used separately or in combination to provide for appropriate evaluations.

4.5 Any variation from test procedure should be noted on the appropriate test form and in the end results as notification of variance.

5. Conditioning

5.1 Before testing, condition units for a minimum of 8 h at $23 \pm 2.8^\circ\text{C}$ ($73.4 \pm 5^\circ\text{F}$), with a relative humidity of $50 \pm 5\%$, 5°F in a flat position.

6. Firmness Rating

FIRMNESS RATING FOR INNERSPRING AND FLEXIBLE FOUNDATION

6.1 *Specimen*—The unit to be tested is an un-upholstered mattress core or flexible foundation unit. Adjustable firmness type cores should note the firmness setting of the core on the appropriate test form.

6.2 Apparatus:

6.2.1 *Platen*—The platen shall be a round rigid disk with a diameter of 344 ± 5 mm (13.54 ± 0.2 in.) connected to the loading mechanism with a flexible connection (see Fig. 1).

6.2.2 *Loading Mechanism*³—A device capable of providing a load of 1335 N (300 lbf) or more with accuracy of $\pm 1\%$.

6.2.3 *Deflection Device*—For use in determining deflection, that is, ruler or electronic device accurate to 1 mm ($1/32$ in.) with minimum stroke of 101.6 mm (4 in.).

6.3 Test Procedure:

6.3.1 Place specimen directly onto a rigid, flat surface.

³ See Practices E4 for calibration techniques.

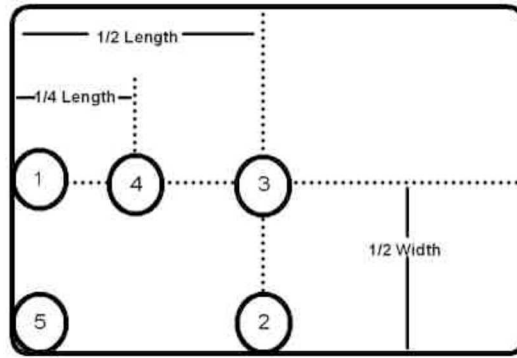

Procedure 6A - Innerspring/Boxspring Test Locations

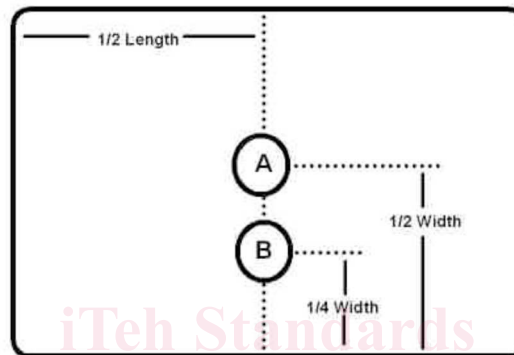

Procedure 6B - Mattress/Mattress Set Firmness Locations

NOTE 1—Procedure 6A: At Locations 1, 2, and 5, platen is flush outside of border (Location 5 is optional).

NOTE 2—Procedure 6B: A – 3/3 and 4/6 Width; B – 5/0 and 6/6 Width.

NOTE 3—Platen Size (both): 343.9 ± 8 mm (13.54 ± 0.2 in.) diameter.

FIG. 2 Firmness Test Locations

6.3.2 At each specimen location as shown in Fig. 2 Procedure 2A with the platen applied, the zero reference point shall be determined using common contact force of 4.4 N (1 lb).

6.3.3 Run tests at four separate locations as shown in Fig. 2; Procedure 6A. Location 5 being optional.

INNERSPRING

6.3.4 At each test location, determine resistance values in 2-N (0.5-lbf) increments at location as the platen is pushed down into the unit, measure the force rounded to the nearest 2 N (0.5 lb) at depths of 12.5, 25, 38, 50, 63, and 76 mm (0.5, 1, 1.5, 2, 2.5, and 3 in.) with a tolerance of ±1 mm (±0.04 in.) of deflection of (± 0.04 in.) from the top surface for innersprings and 12.5 and 25 mm (0.5 and 1 in.) with a tolerance of ±1 mm (±0.04 in.) of deflection of the top surface for flexible foundations. of the innerspring unit.

FLEXIBLE FOUNDATION

6.3.4.1 At each test location as the platen is pushed down into the unit, measure the force rounded to the nearest 2 N (0.5 lb) at depths of 12.5 and 25 mm (0.5 and 1 in.) with a tolerance of ±1 mm (± 0.04 in.) from the top surface of the flexible foundation.

6.3.4 The zero reference point shall be determined using a common contact force of 4.4 N (1 lb).

6.3.5 The test speed is 50 ± 5 mm/min (2 ± 0.2 in./min).

6.4 Calculation/Results:

6.4.1 Determine a firmness rating for a uniformly constructed innerspring unit by totaling resistance values at Locations 3 and 4 for all deflections and dividing the total by two for an average.

6.4.2 Determine firmness rating for a non-uniformly constructed (posturized) innerspring unit by using resistance values at Location 3 only.

6.4.3 Determine a firmness rating for the calf/shoulder area using the values at Location 4 only. Any difference between readings 3 and 4 will be calculated as a percentage of increase of Location 3 over the readings at Location 4.

6.4.4 Determine a firmness rating for the edge by totaling the resistance values at Locations 1 and 2 for all deflections and dividing the total by two for an average.

6.4.5 *Optional*—Determine a firmness rating of the corner by totaling the resistance value for all deflections at Location 5.

MATTRESS OR MATTRESS SET, OR BOTH

6.5 *Specimen*—The unit to be tested is a mattress or mattress set. Adjustable firmness type mattresses should note the firmness setting of the mattress on the appropriate test form.

6.6 Apparatus:

6.6.1 *Platen*—The platen shall be a round rigid disk with a diameter of 344 ± 5 mm (13.54 ± 0.2 in.) connected to the loading mechanism with a flexible connection (see Fig. 1).

6.6.2 *Loading Mechanism*³—A device capable of providing a load of 1335 N (300 lbf) or more with accuracy of ± 1 %.

6.6.3 *Deflection Device*—For use in determining deflection, that is, a ruler or electronic device accurate to 1 mm ($1/32$ in.) with a minimum stroke of 203.2 mm (8 in.).

6.7 Test Procedure:

6.7.1 Place specimen directly onto a rigid flat surface.

6.7.2 Run test at $1/4$ width – $1/2$ length for King and Queen samples and $1/2$ width – $1/2$ length for Full and Twin samples (see Fig. 2).

6.7.3 Preflex the area to be tested by twice lowering the platen at a rate of 250 mm/min (10 in./min) to a load of 778 ± 5 N (175 ± 1 lbf). Allow the sample to rest 6 ± 1 min after preflex.

6.7.4 Preload the sample to a 4.4 N (1 lbf). ~~Record overall height of sample with 4.4 N (1 lbf) applied. Begin recording resistance values in~~ At each test location as the platen is pushed down into the unit, record the force rounded to the nearest 2 N (0.5 lbf) increments lb at 12.5 mm (0.5 in.) intervals with a tolerance of ± 1 mm (± 0.04 in.) until a load of 778 N (175 lbf) load lb is achieved.

6.7.5 The zero reference point and height of sample shall be determined using a common contact force of 4.4 N (1 lb).

6.7.6 The test speed is 50 ± 5 mm/min (2 ± 0.2 in./min).

6.8 Calculation/Results:

6.8.1 Determine mattress or mattress set, or both, firmness rating by dividing the 778 N (175 lbf) test load by the deflection needed to achieve that load. Firmness value shall be recorded in N/mm (lb/in.).

6.8.2 Determine mattress or mattress set, or both, spring rate by graphically representing the load/deflection values through the 778 N (175 lbf) test load.

6.8.3 *Optional*—Alternate positions may be ran for comparative analysis.

7. Durability Test

INNERSPRING OR BOXSPRING, OR BOTH

7.1 *Specimen*: ~~Specimen~~—Any innerspring or boxspring, or both.

7.1.1 When testing mattress componetry, innerspring, a standard upholstered foundation shall be used for the comparison. Conversely, when testing a foundation unit, standard innerspring mattresses shall be used. A 312-coil, 13-gauge, 2.34-mm (0.092-in.) diameter, tempered steel spring wire, 5-turn, shall be the standard test innerspring unit and an 81-coil, 10-gauge, 3.4-mm (0.135-in.) diameter, tempered steel spring wire boxspring unit shall be the standard foundation construction.

7.1.2 The test upholstery for the standard innerspring mattress will be a 52.4 ± 4 g/m² (1.85 ± 0.15 -oz/ft²) synthetic fiber pad primary insulation layer positioned next to the subject on both flat surfaces. A 19-mm (0.75-in.) thick, 17.5 ± 1.5 -kg/m³ (1.1 ± 0.1 -lb/ft³) density, 110 to 155-N (25 to 35-lbf) polyurethane foam cushioning layer shall be placed on top of the primary insulator pad on each side. A quilt assembly sandwich shall be constructed consisting of a top layer of 100-end damask fabric ticking. The middle layer of 13-mm (0.5-in.) thick, 17.5 ± 1.5 -kg/m³ (1.1 ± 0.1 -lb/ft³) density, 110 to 155-N (25 to 35-lbf) polyurethane foam and the bottom layer is of 34 ± 17 -g/m² (1.0 ± 0.5 -oz/yd²) quilt backing.

7.1.3 This assembly shall be unitized by automatic sewing and then placed over the foam cushioning layer on both sides and attached to the subject mattress innerspring, using techniques commonly accepted by the bedding industry.

7.1.4 The standard foundation assembly shall be upholstered with a 52.4 ± 4.0 -g/m² (1.85 ± 0.15 -oz/ft²) synthetic fiber pad primary insulator next to the subject boxspring. The fabric of commercially acceptable grades shall be placed directly over the pad and attached to the spring and wood assembly, using techniques commonly accepted by the bedding industry.

7.1.5 For direct comparative analysis of component testing, mattress and foundation constructions may be altered. All compared product must be mated with a like mattress or foundation constructions.

7.1.6 Analysis of differing mattress sets may be compared when like durability procedure is conducted.

MATTRESS OR MATTRESS SET, OR BOTH

7.2 *Specimen*—Any finished mattress or mattress set.

7.3 *Apparatus*:

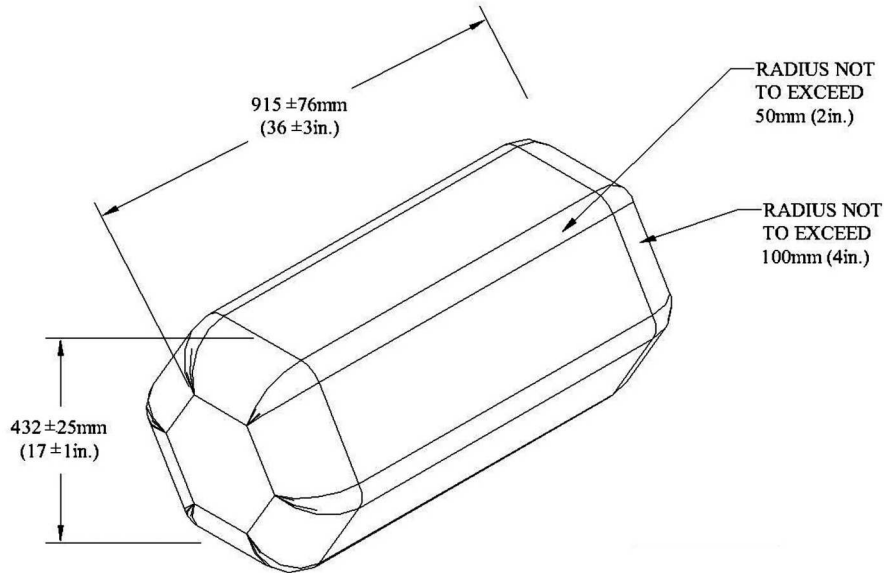

NOTE 1—Total Mass: $109 \pm 4 \text{ kg}$ ($240 \pm 10 \text{ lb}$).

FIG. 3 Roller

7.3.1 Juggernaut Roller⁴(see Fig. 3),

7.3.1.1 Shape of Roller, six-sided,

7.3.1.2 Length, $915 \pm 75 \text{ mm}$ ($36 \pm 3 \text{ in.}$),

7.3.1.3 Weight, $109 \pm 4.5 \text{ kg}$ ($240 \pm 10 \text{ lb}$),

7.3.1.4 Diameter of Roller (Flat to Flat), $432 \pm 25 \text{ mm}$ ($17 \pm 1 \text{ in.}$),

7.3.1.5 All Sharp-Edged Radiuses, not to exceed 50 mm (2 in.) on face of roller and 100 mm (4 in.) on end cap of roller,

7.3.1.6 Operating Speed, not to exceed 20 cycles/min, and

7.3.1.7 Roller, shall float free in the vertical direction of the arm.

7.3.1.8 The driving forces should act horizontally no more than $(-0^\circ, +2^\circ)$.

7.4 Test Procedure:

7.4.1 Determine a firmness rating and height of the specimen in accordance with ~~6.16.7 through 6.4~~ or ~~6.5 through 6.8~~.

7.4.2 Measure height of mattress or mattress set in accordance with ~~6.5 through 6.8~~ for mattress or mattress set.

7.4.2 Durability testing shall be done in the center of the mattress (measured from head to foot) across the mattress surface from side to side.

7.4.3 A hold down device may be used outside of the roller path to keep mattress from moving.

7.4.4 The maximum stroke of the roller shall be the width of the mattress, minus the width of one flat side of the roller.

7.4.5 The minimum stroke shall be no less than 70 % of the width of the mattress, or 965 mm (38 in.), whichever is smaller.

7.4.6 The roller starting position, measured from the center line of the roller, shall be one half the width of the roller from the side of the mattress, with the flat face of the roller resting on the surface of the mattress.

7.4.7 Stroke is determined by one pass across the test area and a cycle determined by two strokes or two passes.

7.4.8 The mattress shall remain in the same position throughout the entire test. If the test is interrupted for a period greater than 30 min, the roller shall be lifted from the set and returned to the original starting position for testing to resume.

7.4.9 The test shall be continued for a total of 100 000 cycles.

7.4.10 Allow to sample recover for $60 \pm 15 \text{ min}$.

7.4.11 Determine the final firmness rating and height of the specimen in accordance with ~~6.56.7 through 6.8~~.

7.5 Report—Report the following information:

7.5.1 Any decrease/increase in height,

7.5.2 Any change in firmness rating, and

7.5.3 Any damage or structural observations.

8. Impact Test

8.1 Specimen—See specimen descriptions in 7.1 and 7.2.

8.2 Apparatus:

⁴ Detailed construction drawings for this equipment are available from American Innerspring Manufacturers Association, 1918 North Parkway, Memphis, TN 38112.

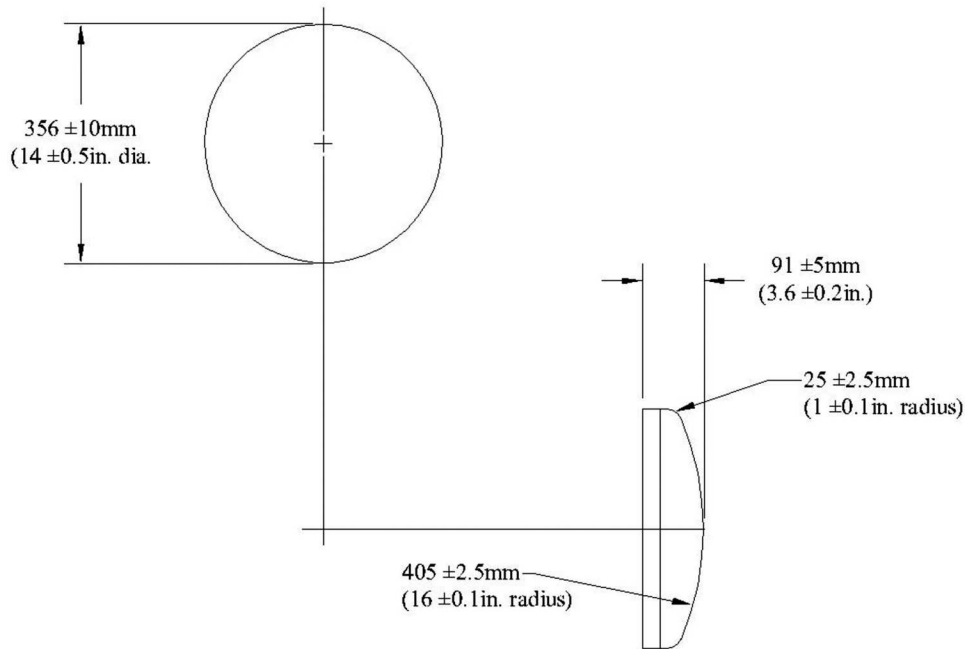

NOTE 1—Total Weight: 79.38 ± 1 kg (175 ± 2 lb).

FIG. 4 Impact Platen

8.2.1 *Platen*—A 356 ± 10 -mm (14.0 ± 0.5 -in.) diameter disk as shown in Fig. 4 with a total mass of 79.5 ± 1.0 kg (175 ± 2 lb).

8.2.2 *Drop Weight Equipment*—A device capable of lifting the platen to a controlled height over the top surface of the specimen and designed to release the platen in “free drop” such that the vertical component is free but the horizontal component is restrained.

8.3 *Test Procedure:*

8.3.1 Place the specimen directly on a rigid, flat surface.

8.3.2 Select drop locations to compare performance at various positions (1 through 5) as shown in Fig. 2:

NOTE 1—For safety reasons, it is recommended that the platen not extend beyond the edge/end of the mattress during any drop test to prevent high side loads from being generated.

8.3.3 Measure the original height of the specimen at Locations 1 through 5 as shown in Fig. 2. Height must be measured from the top of the specimen to the bottom of the support span. Any change in height would be recorded as permanent set or deformation.

8.3.4 Drop heights are measured above the surface of the mattress at the location being tested.

8.3.5 For comparative testing, the drop height shall be constant for each sample set being tested.

8.3.6 Drop the platen from a height of 25 mm (1 in.) above the surface of the mattress at each of five positions (see Fig. 2).

8.3.7 Measure the heights of the specimen at five positions (see 8.3.3).

8.3.8 Repeat 8.3.6 and 8.3.7 at 25-mm (1-in.) increments until there is a 19-mm (0.75-in.) permanent deformation or structural failure.

8.4 *Calculation/Results:*

8.4.1 Record after each series of impacts the following information:

8.4.1.1 Permanent deformation of support elements, and

8.4.1.2 Any structural failures.

9. Firmness Retention and Surface Deformation

9.1 *Specimen*—See specimen descriptions in 7.1 and 7.2.

9.2 *Principle:*

9.2.1 *Testing Machine (commonly referred to as the Cornell Tester):*

9.2.1.1 Applies repeated controlled, counted strokes of a rounded end plunger (ram head) acting on the surface of the mattress set,

9.2.1.2 Measures the support firmness of the mattress set,

9.2.1.3 Measures the deformation of the mattress set in the form of a dimple on the surface of the mattress, and