



Designation: C170/C170M – 14a

Standard Test Method for Compressive Strength of Dimension Stone¹

This standard is issued under the fixed designation C170/C170M; the number immediately following the designation indicates the year of original adoption or, in the case of revision, the year of last revision. A number in parentheses indicates the year of last reapproval. A superscript epsilon (ϵ) indicates an editorial change since the last revision or reapproval.

This standard has been approved for use by agencies of the U.S. Department of Defense.

1. Scope

1.1 This test method covers the sampling, preparation of specimens, and determination of the compressive strength of dimension stone.

1.2 The values stated in either SI units or inch-pound units are to be regarded separately as standard. The values stated in each system may not be exact equivalents; therefore, each system shall be used independently of the other. Combining values from the two systems may result in non-conformance with the standard.

1.3 *This standard does not purport to address all of the safety concerns, if any, associated with its use. It is the responsibility of the user of this standard to establish appropriate safety and health practices and determine the applicability of regulatory limitations prior to use.*

2. Referenced Documents

2.1 *ASTM Standards:*²

C39 Test Method for Compressive Strength of Cylindrical Concrete Specimens

C119 Terminology Relating to Dimension Stone

D4543 Practices for Preparing Rock Core as Cylindrical Test Specimens and Verifying Conformance to Dimensional and Shape Tolerances

D7012 Test Methods for Compressive Strength and Elastic Moduli of Intact Rock Core Specimens under Varying States of Stress and Temperatures

E4 Practices for Force Verification of Testing Machines

3. Terminology

3.1 *Definitions*—All definitions are in accordance with Terminology C119.

¹ This test method is under the jurisdiction of ASTM Committee C18 on Dimension Stone and is the direct responsibility of Subcommittee C18.01 on Test Methods.

Current edition approved Oct. 15, 2014. Published November 2014. Originally approved in 1941. Last previous edition approved in 2014 as C170/C170M-14. DOI: 10.1520/C0170_C0170M-14A.

² For referenced ASTM standards, visit the ASTM website, www.astm.org, or contact ASTM Customer Service at service@astm.org. For *Annual Book of ASTM Standards* volume information, refer to the standard's Document Summary page on the ASTM website.

4. Significance and Use

4.1 This test method is useful in indicating the differences in compressive strength between the various dimension stones. This test method also provides one element in comparing stones of the same type.

5. Apparatus

5.1 The testing machine used shall conform to the requirements of Test Method C39, Section 5, including the calibration requirements of Practices E4.

5.2 The testing machine used shall be capable of applying the required load at a uniform rate as prescribed in Section 9 and applying load in a steady manner as to avoid sudden or rapid load changes.

5.3 The spherical bearing block of the testing machine shall be suspended from the upper head so that the contact plate remains in a central position (spherical surfaces in full contact) when not loaded. The spherical surfaces shall be well lubricated, and the center of curvature shall be aligned within the surface of contact with the specimen.

5.4 Fig. 1 illustrates the correct alignment of a specimen and the typical components of a testing machine conforming to these requirements.

6. Sampling

6.1 The sample shall be selected to represent a true average of the type or grade of stone under consideration and shall be of the quality supplied to the market in finished form under the type designation to be tested. The sample may be selected by the purchaser or his authorized representative from quarried stone or taken from the natural ledge and shall be of adequate size to permit the preparation of the desired number of test specimens. When perceptible variations occur, the purchaser may select as many samples as are necessary for determining the variation in compressive strength.

7. Test Specimens

7.1 The test specimens may be cubes or right cylinders and shall be cut from the sample with saws or core drills. The diameter or lateral dimension (distance between opposite vertical surfaces) shall be not less than 2 in. [50 mm]

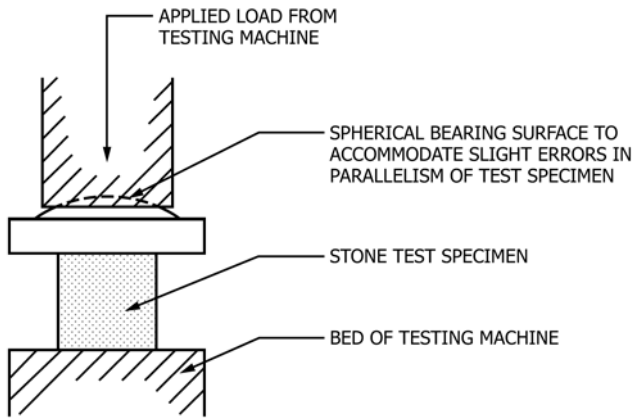

FIG. 1 Diagram of a Specimen Properly Aligned within a Testing Apparatus Suitable for Compressive Strength Testing

dimensional to accommodate variations in the grain size or composition of the sample (Explanatory Note 1).

7.2 The ratio of height (the distance between the surfaces in contact with the testing apparatus) to the diameter or lateral dimension shall be between 0.9:1.0 and 1.1:1.0 (Explanatory Note 2).

7.3 The sides of the specimen shall be smooth and straight to within 0.02 in. [0.5 mm] over the full height of the specimen.

7.4 The two surfaces in contact with the testing apparatus shall have a fine abrasive finish, and the other surfaces shall have a fine sawn finish (Explanatory Note 5). The surfaces in contact with the testing apparatus shall be ground or lapped to a flatness tolerance of plus or minus 0.005 in. [0.1 mm], and shall not depart from perpendicular to the longitudinal axis of the specimen by more than 0.25 deg.

7.5 At least five specimens shall be prepared for each test condition. Final test conditions are determined by the project conditions and specified with the testing request. Typically, testing includes wet and dry conditions both perpendicular and parallel to the stone rift (plane of easiest splitting, typically consistent with the bedding plane orientation), requiring a minimum of 20 specimens. Fig. 2a and Fig. 2b illustrate the proper placement of test specimens within a testing apparatus for the two most common rift orientations. The load-bearing surfaces shall be finished by grinding to as nearly true and parallel planes (Explanatory Note 5) as practicable.

7.6 The load-bearing surfaces and the direction of rift shall be marked on each specimen.

7.7 Use of capping materials or end surfacing treatments other than grinding shall not be permitted.

8. Conditioning

8.1 Before testing the specimens in a dry condition, dry them for 48 h at $140 \pm 4^\circ\text{F}$ [$60 \pm 2^\circ\text{C}$]. At the 46th, 47th, and 48th h, weigh the specimens to ensure that the weight is the same. If the weight continues to drop, continue to dry the specimens until there are 3 successive hourly readings with the same weight. After removing the specimens from the oven, cool them to room temperature in a desiccator before testing them.

8.2 Before testing the specimens in a wet condition, immerse them in water for 48 h at $72 \pm 4^\circ\text{F}$ [$22 \pm 2^\circ\text{C}$]. Test them immediately upon removal from the bath, wiping the specimens free of surface water.

9. Procedure

9.1 The load-bearing area of each specimen shall be calculated from measurements taken midway between the surfaces in contact with the testing apparatus and calculated to the nearest 0.1 in.²[60 mm²]. An alternate approach for determining the load-bearing area is to calculate the areas of the top and bottom bearing surfaces to the nearest 0.1 in.²[60 mm²] and average these values.

9.2 Center the specimens in the testing machine and apply an initial seating load that will hold the specimen in place but still permit hand adjustment of the contact plate on the specimen. Rotate the contact plate back and forth through an angle of approximately 30 deg. to properly seat the spherical block, but do not move the specimen out of the central position.

9.3 Apply load at a uniform rate not exceeding 100 psi/s [0.5 MPa/s].

9.4 Apply the load until specimen failure. Failure of the specimen is defined as the inability of the specimen to resist additional load.

9.5 Record the load at failure to the nearest 100 lb [500 N].

10. Calculation

10.1 Calculate the compressive strength of each specimen as follows:

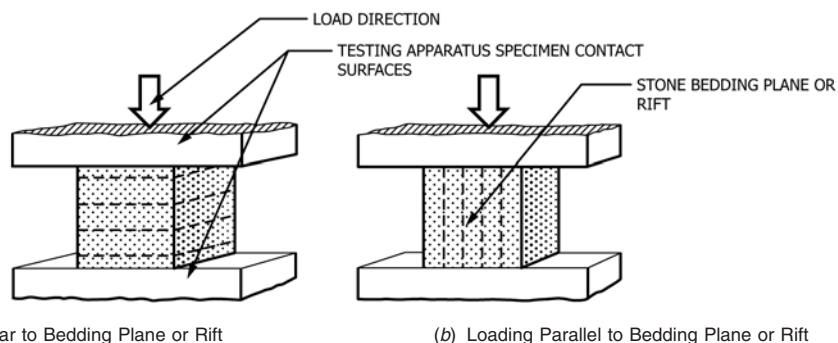

FIG. 2 Orientation of Specimen in a Testing Apparatus with Respect to Bedding Plane or Rift