



Designation: **F746 – 04 (Reapproved 2009)^{ε1} F746 – 04 (Reapproved 2014)**

Standard Test Method for Pitting or Crevice Corrosion of Metallic Surgical Implant Materials¹

This standard is issued under the fixed designation F746; the number immediately following the designation indicates the year of original adoption or, in the case of revision, the year of last revision. A number in parentheses indicates the year of last reapproval. A superscript epsilon (ϵ) indicates an editorial change since the last revision or reapproval.

^{ε1} NOTE—Units information was editorially corrected in January 2010.

1. Scope

1.1 This test method covers the determination of resistance to either pitting or crevice corrosion of metals and alloys from which surgical implants will be produced. It is a modified version of an established test² and is used as a screening test to rank surgical implant alloys in order of their resistance to localized corrosion.

1.2 This test method applies only to passive metals and alloys. Nonpassive alloys (other than noble alloys) are susceptible to general corrosion and are not normally suitable for implant use.

1.3 This test method is intended for use as a laboratory screening test for metals and alloys which undergo pitting or crevice corrosion, or both.

1.4 The values stated in either SI units or inch-pound units are to be regarded separately as standard. The values stated in each system may not be exact equivalents; therefore, each system shall be used independently of the other. Combining values from the two systems may result in non-conformance with the standard.

1.5 *This standard does not purport to address all of the safety concerns, if any, associated with its use. It is the responsibility of the user of this standard to establish appropriate safety and health practices and determine the applicability of regulatory limitations prior to use.*

2. Referenced Documents

2.1 *ASTM Standards:*³

D1193 Specification for Reagent Water

F86 Practice for Surface Preparation and Marking of Metallic Surgical Implants

F2129 Test Method for Conducting Cyclic Potentiodynamic Polarization Measurements to Determine the Corrosion Susceptibility of Small Implant Devices

G3 Practice for Conventions Applicable to Electrochemical Measurements in Corrosion Testing

G5 Reference Test Method for Making Potentiodynamic Anodic Polarization Measurements

G15 Terminology Relating to Corrosion and Corrosion Testing (Withdrawn 2010)⁴

3. Summary of Test Method

3.1 A cylindrical specimen fitted with an inert tapered collar is immersed in a phosphate buffered saline electrolyte at 37°C for 1 h to establish a corrosion potential. Pitting (or crevice corrosion) is then stimulated by potentiostatically polarizing the specimen to a potential much more noble than the corrosion potential. Stimulation of pitting (or crevice corrosion) will be marked by a large and generally increasing polarizing current.

3.2 Immediately after the stimulation step, the potential is decreased as rapidly as possible to one of several preselected potentials at, or more noble than, the corrosion potential. If the alloy is susceptible to pitting (or crevice corrosion) at the

¹ This test method is under the jurisdiction of ASTM Committee F04 on Medical and Surgical Materials and Devices and is the direct responsibility of Subcommittee F04.15 on Material Test Methods.

Current edition approved Dec. 1, 2009; Oct. 1, 2014. Published January 2010; November 2014. Originally approved in 1981. Last previous edition approved in 2004 as F746 – 04; F746 – 04(2009)^{ε1}. DOI: 10.1520/F0746-04R09E01.10.1520/F0746-04R14.

² Syrett, B. C., *Corrosion*, Vol 33, 1977, p. 221.

³ For referenced ASTM standards, visit the ASTM website, www.astm.org, or contact ASTM Customer Service at service@astm.org. For *Annual Book of ASTM Standards* volume information, refer to the standard's Document Summary page on the ASTM website.

⁴ The last approved version of this historical standard is referenced on www.astm.org.

preselected potential, the polarizing current will remain at relatively high values and will fluctuate or increase with time. A post-test examination of the metal specimen establishes whether localized corrosion has occurred by pitting of the exposed surface or by preferential attack at the crevice formed by the tapered collar, or both.

3.3 If the pit (or crevice) surface repassivates at the pre-selected potential and localized corrosion is halted, the polarizing current will drop to values typical for passive surfaces and the current will decrease continuously. The parameter of interest, the critical potential for pitting (or crevice corrosion), is defined as the highest (most noble) pre-selected potential at which pit (or crevice) surfaces repassivate after the stimulation step.

4. Significance and Use

4.1 This test method is designed solely for determining comparative laboratory indices of performance. The results may be used for ranking alloys in order of increasing resistance to pitting and crevice corrosion under the specific conditions of this method. It should be noted that the method is intentionally designed to reach conditions that are sufficiently severe to cause breakdown of at least one alloy (Type 316 L stainless steel) currently considered acceptable for surgical implant use, and that those alloys which suffer pitting or crevice corrosion during the more severe portions of the test do not necessarily suffer localized corrosion when placed within the human body as a surgical implant.

5. Apparatus

5.1 The following required equipment is described in Reference Test Method G5:

- 5.1.1 *Standard Polarization Cell*, of 1000 cm³.
- 5.1.2 *Electrode Holders*, for auxiliary and working electrodes.
- 5.1.3 *Potentiostat*, calibrated in accordance with Reference Test Method G5.
- 5.1.4 *Potential-Measuring Instrument*.
- 5.1.5 *Current-Measuring Instrument*.
- 5.1.6 *Anodic Polarization Circuit*.
- 5.1.7 *Platinum Auxiliary Electrodes*.
- 5.1.8 *Saturated Calomel Electrode (SCE)*.
- 5.1.9 *Salt Bridge Probe*.

5.2 A cylindrical working electrode is fabricated from the test material by machining, grinding, and suggested final polishing with 600-grit metallographic paper. It is suggested that the part of the cylindrical specimen that is exposed to the test solution have a length of 20.00 ± 1.00 mm [0.787 ± 0.039 in.] and a diameter of 6.35 ± 0.03 mm [0.250 ± 0.001 in.] (see Fig. 1).

5.3 A crevice is created by fitting the cylindrical specimen with a tapered collar, machined from commercial purity polytetrafluoroethylene (PTFE). The collar should have an outer diameter of 12.70 ± 0.05 mm [0.500 ± 0.002 in.] and a thickness of 3.18 ± 0.20 mm [0.125 ± 0.008 in.]. The inside diameter of the tapered collar should range from 0.38 mm [0.015 in.] smaller than the diameter of the specimen to 0.38 mm [0.015 in.] larger. To be consistent with the dimensions suggested in 5.2, the inside diameter should taper from 5.97 ± 0.05 mm [0.235 ± 0.002 in.] to 6.73 ± 0.05 mm [0.265 ± 0.002 in.]. See Fig. 1 for drawing of the tapered collar. The relatively fine tolerances are needed to ensure a reproducible fit and crevice.

5.4 In Reference Test Method G5, the method of specimen attachment is to drill and tap the specimen to receive a threaded stainless steel connection rod. A4-40 thread is used, typically. However, because many surgical implant alloys are not easily drilled,

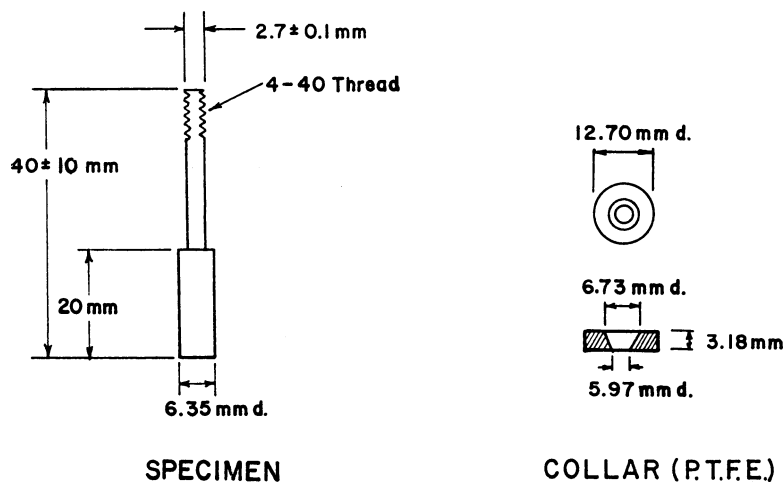

NOTE 1—Unless shown, dimensional tolerances are given in text.

FIG. 1 Dimensions of Specimen and Collar

external threads may also be machined, ground, or cast, as illustrated in Fig. 1. A small stainless steel adapter is fitted onto these threads and the adapter then accepts the connection rod.

5.5 Determine the total exposed surface area of the specimen before placement of the PTFE collar, A_T ; determine the area on the internal surface of the collar (the creviced area), A_C ; and determine the exposed surface area of the specimen after placement of the collar, A_S (where: $A_S = A_T - A_C$). Dimensions should be measured to the nearest 0.1 mm.

5.5.1 Example—Using the dimensions suggested previously for the specimen diameter ($d = 6.35$ mm), the specimen length ($l = 20.00$ mm), and the collar thickness ($t = 3.18$ mm),

$$A_T = \pi dl + \frac{\pi d^2}{4} = 431 \text{ mm}^2 \quad (1)$$

$$A_C = \pi dt = 63 \text{ mm}^2 \quad (2)$$

$$A_S = A_T - A_C = 386 \text{ mm}^2 \quad (3)$$

6. Reagents

6.1 *Electrolyte*—Unless otherwise specified, phosphate buffered saline (PBS) should be used as the standard test solution. A standard PBS formulation (see Table X2.3 of Test Method F2129) is the following: NaCl 8.0 g/L, KCl 0.2 g/L, $\text{Na}_2\text{HPO}_4 \cdot 12\text{H}_2\text{O}$ 1.15 g/L, KH_2PO_4 0.2 g/L, and bring to 1 L volumetrically using distilled water.

6.1.1 The water shall be distilled conforming to the purity requirements of Specification D1193, Type IV reagent water.

6.1.2 After transferring the appropriate amount of electrolyte to the test cell (7.5), the pH is measured both before and after the test.

7. Preparation of Specimens and Conditioning

7.1 Prepare the test specimen surface within 1 h of the start of the experiment by the method described in Reference Test Method G5.

7.2 Using a suitable mechanical jig, force-fit the PTFE collar onto the cylindrical specimen so that the base of the collar is up 10 ± 2 mm [0.393 ± 0.079 in.] from the bottom of the specimen (see Fig. 2). Care should be taken to avoid scratching the metal surface.

NOTE 1—Once the collar is removed from the specimen, it should not be reused.

7.3 Mount the specimen on the holder and on the electrode rod as described in Reference Test Method G5.

7.4 Ultrasonically degrease the electrode assembly in either acetone, toluene, or boiling benzene (with caution, under hood), rinse in distilled water, and dry.

7.5 Transfer 500 mL of electrolyte solution to a clean polarization cell. Bring the temperature of the solution to $37 \pm 1^\circ\text{C}$ by immersing the test cell in a controlled temperature water bath or by other suitable means.

7.6 Place the platinum auxiliary electrodes, salt bridge probe and other components in the test cell and temporarily close the center opening with a stopper. Fill the salt-bridge with the electrolyte.

NOTE 2—The levels of the solution in the reference and the polarization cells should be the same to avoid siphoning. If this is not possible, a

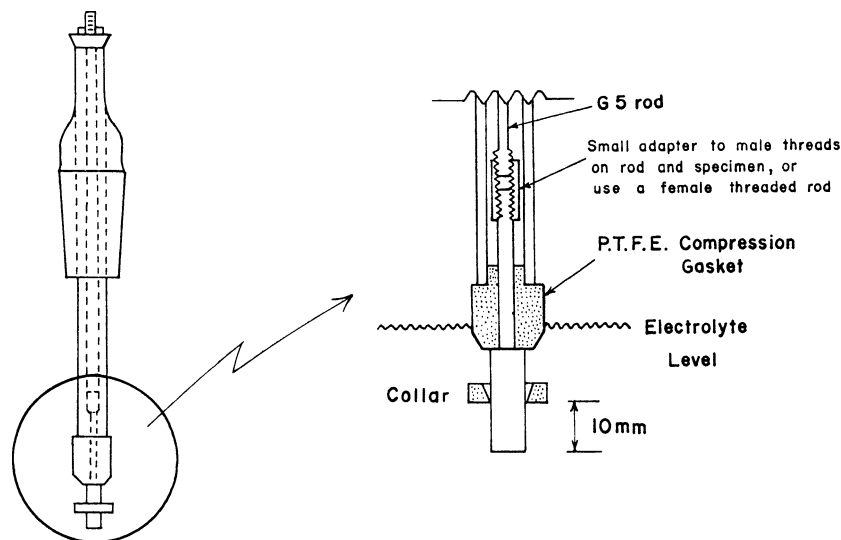

FIG. 2 Assembly into G5 Electrode Holder