



Designation: ~~D305 – 84 (Reapproved 2008)~~ D305 – 84 (Reapproved 2014)

Standard Test Method for Solvent-Extractable Material in Black Pigments¹

This standard is issued under the fixed designation D305; the number immediately following the designation indicates the year of original adoption or, in the case of revision, the year of last revision. A number in parentheses indicates the year of last reapproval. A superscript epsilon (ϵ) indicates an editorial change since the last revision or reapproval.

This standard has been approved for use by agencies of the U.S. Department of Defense.

1. Scope

1.1 This test method covers the determination of the solvent-extractable material in black pigments such as carbon black, lampblack, and bone black.

1.2 The values stated in SI units are to be regarded as the standard. The values given in parentheses are for information only.

1.3 *This standard does not purport to address all of the safety concerns, if any, associated with its use. It is the responsibility of the user of this standard to establish appropriate safety and health practices and determine the applicability of regulatory limitations prior to use.*

2. Referenced Documents

2.1 *ASTM Standards:*²

[D329 Specification for Acetone](#)

3. Significance and Use

3.1 This test method is used by black pigment producers and users for product acceptance.

4. Apparatus

4.1 *Extraction Apparatus*, consisting of a flask, siphon cup, and a condenser similar to the apparatus shown in either [Fig. 1](#) or [Fig. 2](#).

NOTE 1—A Siphlet apparatus may be used as an alternative.

4.2 *Extraction Thimbles*—The thimble must be made of greaseless paper and be of correct size to fill the selected apparatus.

<https://standards.iteh.ai/catalog/standards/sist/a0839082-4848-439d-9a42-e89d179d7dc9/astm-d305-842014>

¹ This test method is under the jurisdiction of ASTM Committee D01 on Paint and Related Coatings, Materials, and Applications and is the direct responsibility of Subcommittee D01.31 on Pigment Specifications.

Current edition approved Feb. 1, 2008; Dec. 1, 2014. Published February 2008; December 2014. Originally approved in 1929. Last previous edition approved in 2003-2008 as D305 – 84 (2003)-(2008). DOI: [10.1520/D0305-84R08](https://doi.org/10.1520/D0305-84R08); [10.1520/D0305-84R14](https://doi.org/10.1520/D0305-84R14).

² For referenced ASTM standards, visit the ASTM website, www.astm.org, or contact ASTM Customer Service at service@astm.org. For *Annual Book of ASTM Standards* volume information, refer to the [standard's Document Summary page](#) on the ASTM website.

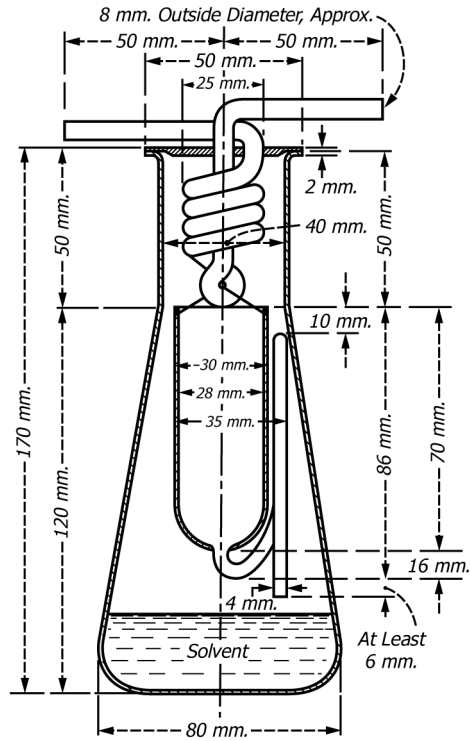

FIG. 1 Extraction Apparatus

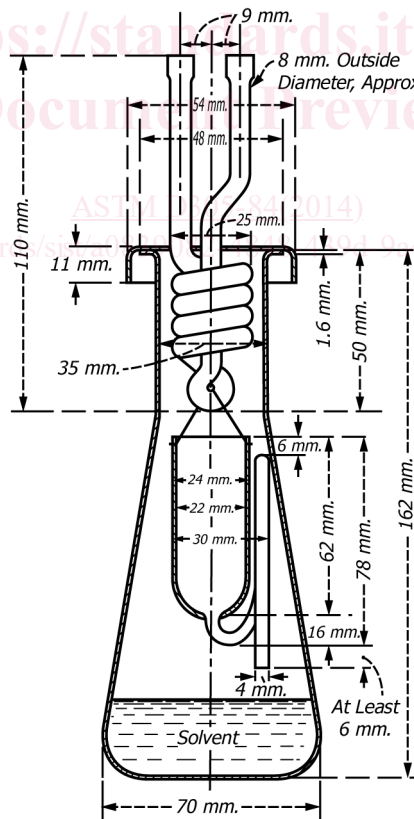

FIG. 2 Extraction Apparatus

NOTE 2—The recommended thimble size for each of the apparatus shown in Fig. 1 is listed below: