



Designation: D1200 – 10 (Reapproved 2014)

Standard Test Method for Viscosity by Ford Viscosity Cup¹

This standard is issued under the fixed designation D1200; the number immediately following the designation indicates the year of original adoption or, in the case of revision, the year of last revision. A number in parentheses indicates the year of last reapproval. A superscript epsilon (ϵ) indicates an editorial change since the last revision or reapproval.

This standard has been approved for use by agencies of the U.S. Department of Defense.

1. Scope

1.1 This test method covers the determination of the viscosity of Newtonian or near-Newtonian paints, varnishes, lacquers, and related liquid materials with the Ford-type efflux viscosity cup. If the material is non-Newtonian, that is, shear-thinning or thixotropic, Test Method D2196 should be used.

1.2 The values stated in SI units are to be regarded as the standard. The values given in parentheses are for information only.

1.3 *This standard does not purport to address all of the safety concerns, if any, associated with its use. It is the responsibility of the user of this standard to establish appropriate safety and health practices and determine the applicability of regulatory limitations prior to use.*

2. Referenced Documents

2.1 *ASTM Standards:*²

D2196 Test Methods for Rheological Properties of Non-Newtonian Materials by Rotational (Brookfield type) Viscometer

E1 Specification for ASTM Liquid-in-Glass Thermometers

3. Terminology

3.1 *Definitions:*

3.1.1 *Newtonian liquid, n*—a liquid in which the viscosity is independent of the shear stress or shear rate. If the ratio of shear stress to shear rate is not constant, the liquid is non-Newtonian.

3.1.2 *Near-Newtonian liquid, n*—a liquid in which the variation of viscosity with shear rate is small and the effect on viscosity of mechanical disturbances such as stirring is negligible.

¹ This test method is under the jurisdiction of ASTM Committee D01 on Paint and Related Coatings, Materials, and Applications and is the direct responsibility of Subcommittee D01.24 on Physical Properties of Liquid Paints and Paint Materials.

Current edition approved Dec. 1, 2014. Published December 2014. Originally approved in 1952. Last previous edition approved in 2010 as D1200 – 10. DOI: 10.1520/D1200-10R14.

² For referenced ASTM standards, visit the ASTM website, www.astm.org, or contact ASTM Customer Service at service@astm.org. For *Annual Book of ASTM Standards* volume information, refer to the standard's Document Summary page on the ASTM website.

4. Summary of Test Method

4.1 The Ford viscosity cup is filled level full with the liquid under test, and the time for the material to flow through one of the standard orifices is measured.

5. Significance and Use

5.1 This test method is useful for the determination of package and application viscosities of a number of paints and other coatings and in the thinning of these materials, but is limited to Newtonian or near-Newtonian liquids.

5.2 There are other types of apparatus for measuring viscosity in the laboratory that produce more accurate results.

6. Apparatus

6.1 *Ford Viscosity Cups*—Nos. 1, 2, 3, 4, and 5 Ford viscosity cups made of corrosion- and solvent-resistant materials assembled as complete units (Note 1), and conforming to the dimensional requirements shown in Fig. 1. The orifice dimensions are considered as a guide only as the combination of cup and orifice dimensions must permit conformance to the flow formula for each cup as listed in the Appendix.

NOTE 1—If the orifice is removed from the cup for any reason the cup should be recalibrated before use as described in the Appendix.

6.2 *Thermometer*—Saybolt Viscosity Thermometer conforming to the requirements for Thermometer 17C (19 to 27°C) or 17F (66 to 80°F) as prescribed in Specification E1. In addition, temperature measuring devices such as non-mercury liquid-in-glass thermometers, thermocouples, or platinum resistance thermometers that provide equivalent or better accuracy and precision, that cover the temperature range for thermometer 17C and 17F, may be used.

6.3 *Timing Device*—Any timing device may be used providing that the readings can be taken with a discrimination of 0.2 s or better.

7. Test Specimen

7.1 The specimen of the material to be tested shall be visibly homogeneous and free of any foreign material or air bubbles.

8. Temperature of Testing

8.1 All measurements with the Ford viscosity cups shall be made at 25°C (77°F) or a temperature agreed upon between

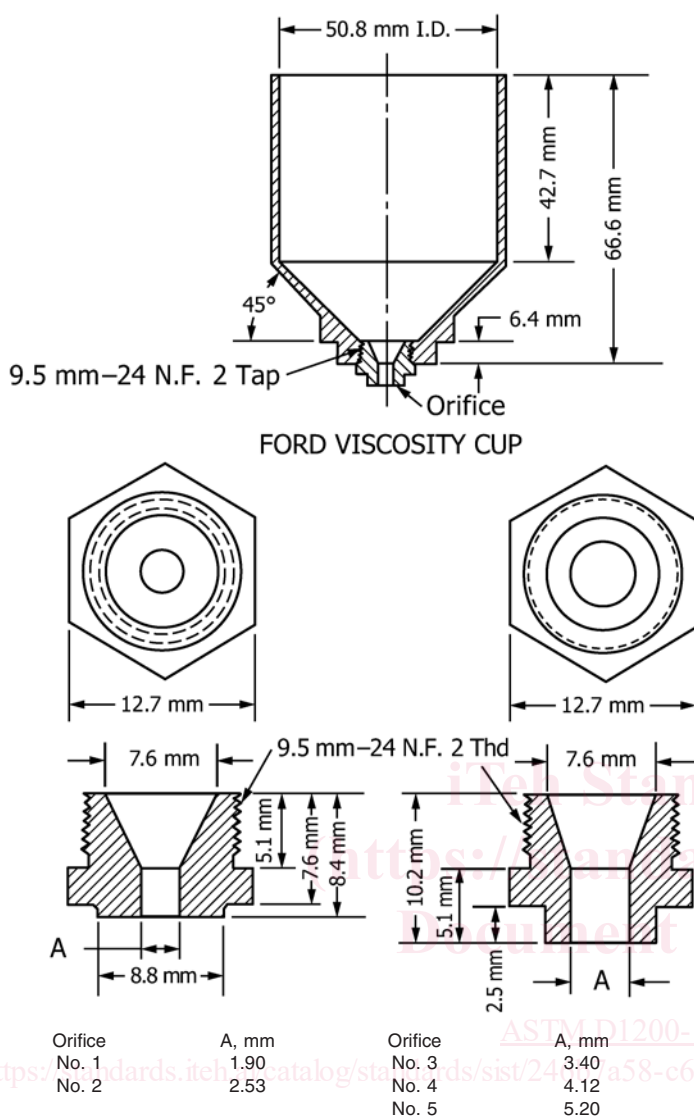

FIG. 1 Ford Viscosity Cup and Orifices

producer and user. Temperature drift during the test should be kept to a minimum and should not exceed $\pm 0.2^\circ\text{C}$ ($\pm 0.4^\circ\text{F}$).

NOTE 2— It is impossible to predict the effect of temperature change on each material with which the apparatus may be used. This factor may be less than 1 % per degree Celsius for some liquids whereas others may be as high as 8 to 10 % per degree Celsius.

9. Calibration

9.1 Cups should be calibrated in accordance with the procedure described in Appendix X1. The frequency of this calibration check depends upon the amount of use and the care that the individual cup receives. If the cup varies more than 10 % from standard, it should not be used.

10. Conditioning

10.1 Bring the material to a temperature a few degrees below that desired and then agitate vigorously for 10 min on a reciprocating shaker in a pint can two-thirds full. Allow to stand undisturbed for 10 min while adjusting further to the

desired temperature. Make the viscosity determination at the end of the 10-min period.

11. Procedure

11.1 Make viscosity determinations in a room free of drafts and rapid changes in temperature. For the highest degree of precision the room temperature should be between 22 and 28°C (72 and 82°F). Determinations should be made at a temperature above the dew point of the atmosphere surrounding the apparatus.

11.2 Choose the proper cup so that the time of efflux will be between 20 and 100 s (preferably between 30 and 100 s) for cup Nos. 3, 4, and 5; between 55 and 100 s for cup No. 1; and between 40 and 100 s for cup No. 2 (Fig. 2).

11.3 Level the instrument so that a cup may be filled level full without a meniscus or overflow at one side.

11.4 Determine the time in seconds of efflux as follows: Close the orifice, for example, by holding a rubber stopper against it. Fill the cup with the prepared specimen. The preferred method is to overfill the cup and scrape off the excess with a straightedge. Pull the stopper away and simultaneously start the timing device. Measure the time until the first break in the stream.

11.5 Measure the temperature of the fluid in the efflux stream.

11.6 If the cup has been established to be nonstandard when calibrated as described in the Appendix, apply the percent difference to the measured seconds to get the corrected viscosity in Ford-cup seconds.

12. Care of Cup

12.1 Following each determination, clean the cup by the use of a suitable solvent and a soft brush. Under no conditions should metal cleaning tools be brought into contact with the instrument. Particular care must be exercised in cleaning the orifice to avoid any film deposit or nicks on the inside walls.

13. Report

13.1 Report the following information:

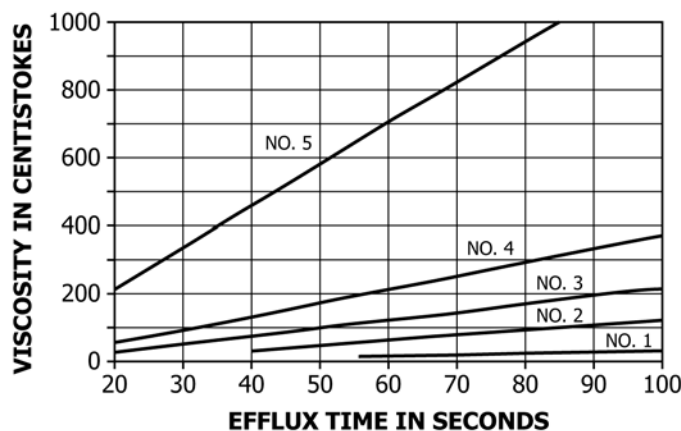

FIG. 2 Approximate Viscosity Curves for Ford Cups