



Designation: ~~D1200 – 10~~ D1200 – 10 (Reapproved 2014)

Standard Test Method for Viscosity by Ford Viscosity Cup¹

This standard is issued under the fixed designation D1200; the number immediately following the designation indicates the year of original adoption or, in the case of revision, the year of last revision. A number in parentheses indicates the year of last reapproval. A superscript epsilon (ϵ) indicates an editorial change since the last revision or reapproval.

This standard has been approved for use by agencies of the U.S. Department of Defense.

1. Scope

1.1 This test method covers the determination of the viscosity of Newtonian or near-Newtonian paints, varnishes, lacquers, and related liquid materials with the Ford-type efflux viscosity cup. If the material is non-Newtonian, that is, shear-thinning or thixotropic, Test Method [D2196](#) should be used.

1.2 The values stated in SI units are to be regarded as the standard. The values given in parentheses are for information only.

1.3 *This standard does not purport to address all of the safety concerns, if any, associated with its use. It is the responsibility of the user of this standard to establish appropriate safety and health practices and determine the applicability of regulatory limitations prior to use.*

2. Referenced Documents

2.1 *ASTM Standards:*²

[D2196 Test Methods for Rheological Properties of Non-Newtonian Materials by Rotational \(Brookfield type\) Viscometer](#)
[E1 Specification for ASTM Liquid-in-Glass Thermometers](#)

3. Terminology

3.1 *Definitions:*

3.1.1 *Newtonian liquid, n*—a liquid in which the viscosity is independent of the shear stress or shear rate. If the ratio of shear stress to shear rate is not constant, the liquid is non-Newtonian.

3.1.2 *Near-Newtonian liquid, n*—a liquid in which the variation of viscosity with shear rate is small and the effect on viscosity of mechanical disturbances such as stirring is negligible.

4. Summary of Test Method

4.1 The Ford viscosity cup is filled level full with the liquid under test, and the time for the material to flow through one of the standard orifices is measured.

5. Significance and Use

5.1 This test method is useful for the determination of package and application viscosities of a number of paints and other coatings and in the thinning of these materials, but is limited to Newtonian or near-Newtonian liquids.

5.2 There are other types of apparatus for measuring viscosity in the laboratory that produce more accurate results.

6. Apparatus

6.1 *Ford Viscosity Cups*—Nos. 1, 2, 3, 4, and 5 Ford viscosity cups made of corrosion- and solvent-resistant materials assembled as complete units ([Note 1](#)), and conforming to the dimensional requirements shown in [Fig. 1](#). The orifice dimensions are considered as a guide only as the combination of cup and orifice dimensions must permit conformance to the flow formula for each cup as listed in the Appendix.

¹ This test method is under the jurisdiction of ASTM Committee [D01](#) on Paint and Related Coatings, Materials, and Applications and is the direct responsibility of Subcommittee [D01.24](#) on Physical Properties of Liquid Paints and Paint Materials.

Current edition approved July 1, 2010Dec. 1, 2014. Published July 2010December 2014. Originally approved in 1952. Last previous edition approved in 20052010 as ~~D1200 – 94 (2005)~~D1200 – 10. DOI: ~~10.1520/D1200-10~~10.1520/D1200-10R14.

² For referenced ASTM standards, visit the ASTM website, www.astm.org, or contact ASTM Customer Service at service@astm.org. For *Annual Book of ASTM Standards* volume information, refer to the [standard's Document Summary page](#) on the ASTM website.

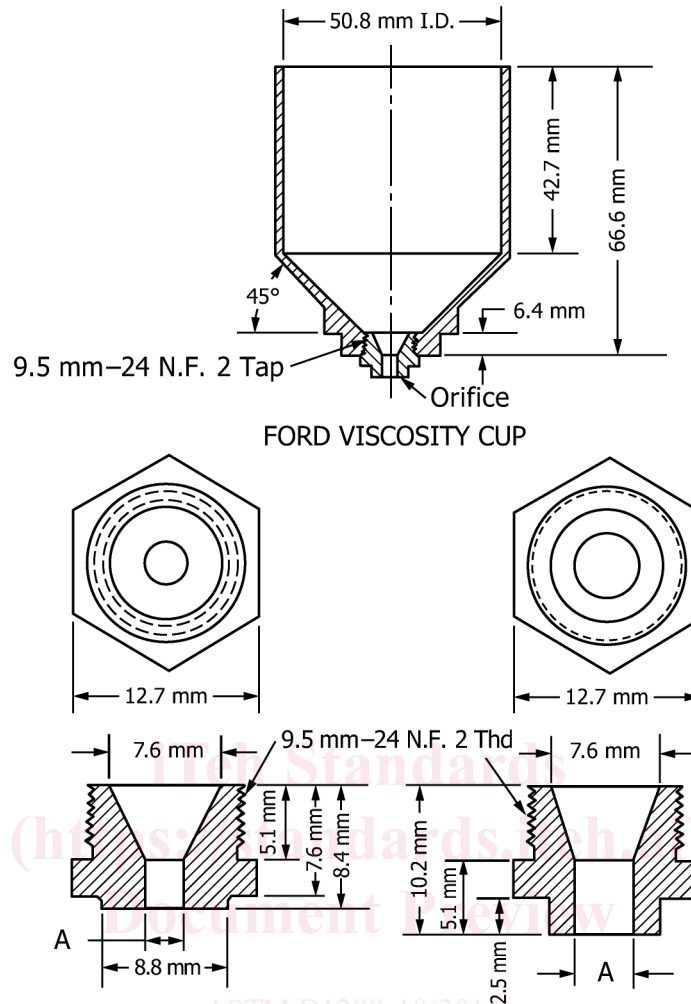

FORD VISCOSITY CUP

Orifice	A, mm	Orifice	A, mm
No. 1	1.90	No. 3	3.40
No. 2	2.53	No. 4	4.12
		No. 5	5.20

FIG. 1 Ford Viscosity Cup and Orifices

NOTE 1—If the orifice is removed from the cup for any reason the cup should be recalibrated before use as described in the Appendix.

6.2 *Thermometer*—Saybolt Viscosity Thermometer conforming to the requirements for Thermometer 17C (19 to 27°C) or 17F (66 to 80°F) as prescribed in Specification E1. In addition, temperature measuring devices such as non-mercury liquid-in-glass thermometers, thermocouples, or platinum resistance thermometers that provide equivalent or better accuracy and precision, that cover the temperature range for thermometer 17C and 17F, may be used.

6.3 *Timing Device*—Any timing device may be used providing that the readings can be taken with a discrimination of 0.2 s or better.

7. Test Specimen

7.1 The specimen of the material to be tested shall be visibly homogeneous and free of any foreign material or air bubbles.

8. Temperature of Testing

8.1 All measurements with the Ford viscosity cups shall be made at 25°C (77°F) or a temperature agreed upon between producer and user. Temperature drift during the test should be kept to a minimum and should not exceed ±0.2°C (±0.4°F).

NOTE 2— It is impossible to predict the effect of temperature change on each material with which the apparatus may be used. This factor may be less than 1 % per degree Celsius for some liquids whereas others may be as high as 8 to 10 % per degree Celsius.