



Designation: ~~D4212 – 10~~ **D4212 – 10 (Reapproved 2014)**

Standard Test Method for Viscosity by Dip-Type Viscosity Cups¹

This standard is issued under the fixed designation D4212; the number immediately following the designation indicates the year of original adoption or, in the case of revision, the year of last revision. A number in parentheses indicates the year of last reapproval. A superscript epsilon (ϵ) indicates an editorial change since the last revision or reapproval.

1. Scope

1.1 This test method covers the determination of viscosity of paints, varnishes, lacquers, inks, and related liquid materials by dip-type viscosity cups. This test method is recommended for viscosity control work within one plant or laboratory and should be used to check compliance with specifications only when sufficient controls have been instituted to ensure adequate comparability of results.

1.2 Viscosity cups are designed for testing of Newtonian and near-Newtonian liquids. If the test material is non-Newtonian, for example, shear-thinning or thixotropic, another method, such as Test Methods **D2196**, should be used. Under controlled conditions, comparisons of the viscosity of non-newtonian materials may be helpful, but viscosity determination methods using controlled shear rate or shear stress are preferred.

1.3 The values stated in SI units are to be regarded as the standard. The values given in parentheses are for information only.

1.4 *This standard does not purport to address all of the safety concerns, if any, associated with its use. It is the responsibility of the user of this standard to establish appropriate safety and health practices and determine the applicability of regulatory limitations prior to use.*

2. Referenced Documents

2.1 *ASTM Standards:*²

D1200 Test Method for Viscosity by Ford Viscosity Cup

D2196 Test Methods for Rheological Properties of Non-Newtonian Materials by Rotational (Brookfield type) Viscometer

D4287 Test Method for High-Shear Viscosity Using a Cone/Plate Viscometer

E1 Specification for ASTM Liquid-in-Glass Thermometers

3. Terminology

3.1 *Definitions:*

3.1.1 *near-Newtonian liquid, n*—a liquid in which the variation of viscosity with shear rate is small and the effect on viscosity of mechanical disturbances such as stirring is negligible.

3.1.2 *Newtonian liquid, n*—a liquid in which the viscosity is independent of the shear stress or shear rate. If the ratio of shear stress to shear rate is not constant, the liquid is non-Newtonian.

4. Summary of Test Method

4.1 The cup is completely immersed in the material to be tested, withdrawn, and the time for the material to flow through a hole in the base of the cup is measured.

5. Significance and Use

5.1 Viscosity is a measure of the fluidity of a material. Viscosity data are useful in the determination of the ease of stirring, pumping, dip coating, or other flow-related properties of paints and related fluids.

5.2 This type of cup is used to measure viscosity because it is easy to use, robust, and may be used in tanks, reservoirs, and reactors.

¹ This test method is under the jurisdiction of ASTM Committee **D01** on Paint and Related Coatings, Materials, and Applications and is the direct responsibility of Subcommittee **D01.24** on Physical Properties of Liquid Paints and Paint Materials.

Current edition approved July 1, 2010/Dec. 1, 2014. Published July 2010/December 2014. Originally approved in 1982. Last previous edition approved in 2005/2010 as ~~D4212 – 99 (2005)~~ **D4212 – 10**. DOI: ~~10.1520/D4212-10~~ 10.1520/D4212-10R14.

² For referenced ASTM standards, visit the ASTM website, www.astm.org, or contact ASTM Customer Service at service@astm.org. For *Annual Book of ASTM Standards* volume information, refer to the ~~standard's~~ Document Summary page on the ASTM website.

5.3 There are other types of apparatus for measuring viscosity in the laboratory that provide better precision and bias, including the Ford viscosity cup (Test Method D1200), and the Brookfield viscometer (Test Methods D2196).

5.4 Certain higher shear rate devices such as cone/plate viscometers (Test Method D4287) provide more information about sprayability, roll coatability, and other high-shear rate related properties of coatings.

6. Apparatus

6.1 *Zahn Viscosity Cup*—No. 1 through No. 5 Zahn viscosity cups made of corrosion- and solvent-resistant materials. The nominal capacity of the cup is 44 mL, but may vary from 43 to 49 mL, depending on the manufacturer. A diagram of a Zahn cup is given in Fig. 1. The dimensions, including orifices, are only approximate because the cups are not made to a uniform specification. Each manufacturer produces a different cup and considerable variation between batches from some manufacturers has been noted in the past. This is a major reason why Zahn cups should not be referenced in specifications between producer and user only when controls sufficient to ensure adequate cup-to-cup and operator-to-operator comparison are included. (See Appendix X1 for additional information on Zahn Cups.)

NOTE 1—The various cup numbers are for identification of the viscosity ranges within the series only and should not be used for comparison between different kinds of cups, that is, a No. 2 Zahn cup has no relationship whatsoever with a No. 2 Shell cup.

6.1.1 Nominal Zahn cup orifice diameters are listed in Table X2.1. Cup No. 1 with the smallest orifice is used for determining the viscosity of thin-bodied materials. Cup No. 2 is for use with clears, lacquers, enamels, and press-side adjustment of flexographic inks; cups Nos. 3 and 4 are for use with more viscous paints and inks (No. 3 for manufacturing of flexographic inks); and cup No. 5 is used for silk screen inks.

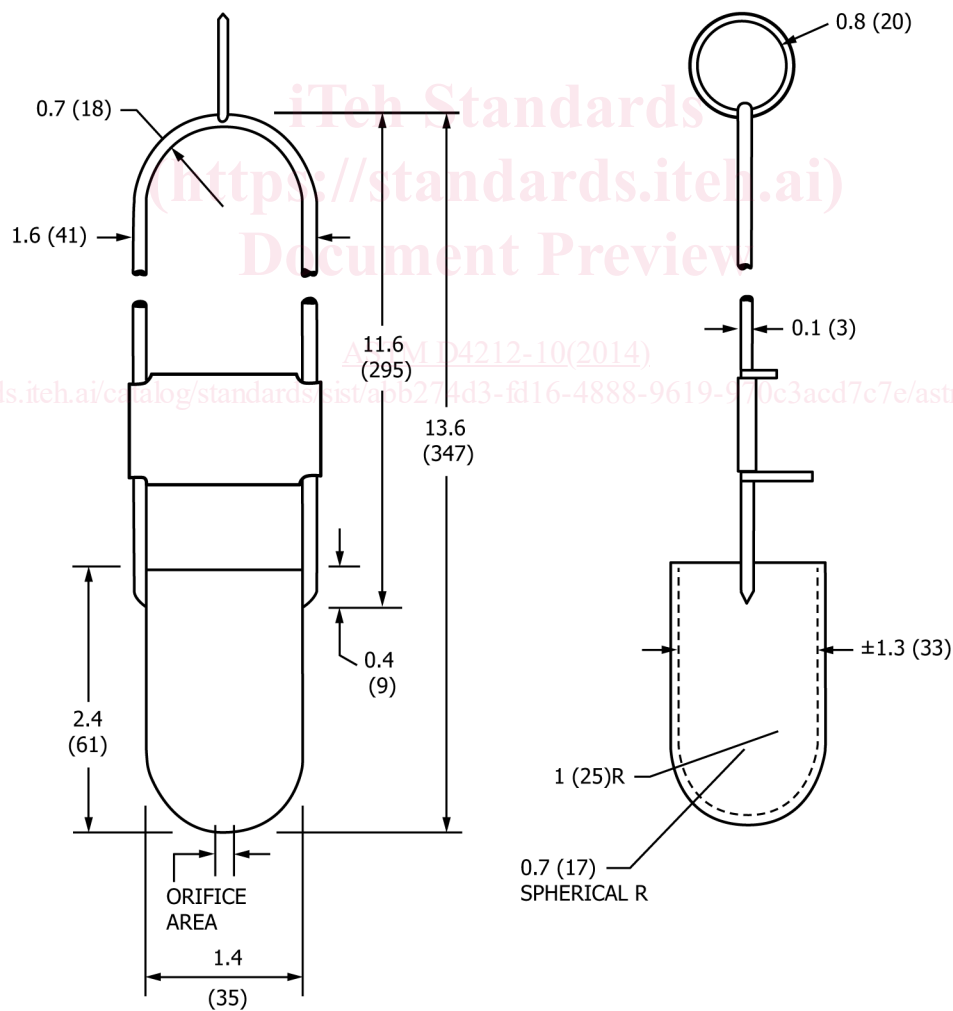

DIMENSIONS IN INCHES
(MILLIMETERS IN PARENTHESES)

NOTE 1—Dimensions are approximate only and may vary with the manufacturer and from batch to batch.

FIG. 1 Zahn Cup Nominal Dimensions

6.2 *Shell Viscosity Cup*³—No. 1 through No. 6 Shell viscosity cups made of stainless steel with a capacity of 23 mL and a 25-mm (1-in.) long capillary in the bottom and conforming to the dimensions shown in Fig. 2.

6.2.1 Nominal Shell cup orifice diameters are listed in Table X2.1. Cup Nos. 1 through 2½ are recommended for use with reduced rotogravure inks; No. 2 is for use with flexographic inks; Nos. 3 through 4 are used for industrial enamels, lacquers, flexographic, and gravure inks; Nos. 5 and 6 are used for heavy materials.

6.3 *Calibration Thermometer*—ASTM Saybolt Viscosity Thermometer 17F having a range of 66 to 80°F and subdivisions of 0.2°F, or 17C having a range of 19 to 27°C and subdivisions of 0.1°C, both conforming to the requirements of Specification E1. Thermometers having subdivisions other than these may be used depending on the sensitivity of the material to be tested, the demands of the application, and the agreement between the purchaser and seller. In addition, temperature measuring devices such as non-mercury liquid-in-glass thermometers, thermocouples, or platinum resistance thermometers that provide equivalent or better accuracy and precision, that cover the temperature range for thermometer 17C and 17F, may be used.

6.4 *Timer*—Any timing device may be used provided that the readings can be taken with a discrimination of 0.1 s or better.

7. Test Materials

7.1 The material to be tested should be visibly homogeneous and free from any foreign material or air bubbles.

8. Temperature of Testing

8.1 Measurements should be made at 25°C (77°F) unless otherwise specified. Temperature drift during the test should be kept to a minimum. The viscosities of paints and related materials are highly dependent on temperature. Differences in temperature between measurements can give substantially different viscosities (up to 5 % per °F). For careful work, the temperature should be taken in the efflux stream, but for process control (such as monitoring a dip tank), this is not necessary.

8.2 A temperature correction curve may be constructed for each liquid by plotting viscosity (seconds) against temperature over the expected temperature range. With this curve, a viscosity determined at one measured temperature may be converted quickly to a viscosity at another temperature.

NOTE 2—When dip cups are used for original purposes, that is thinning or monitoring of materials in tanks, coaters, etc., temperature is not important. This is because the key to good operation is to maintain the fluid within a certain range of dip cup-seconds regardless of the temperature of the fluid.

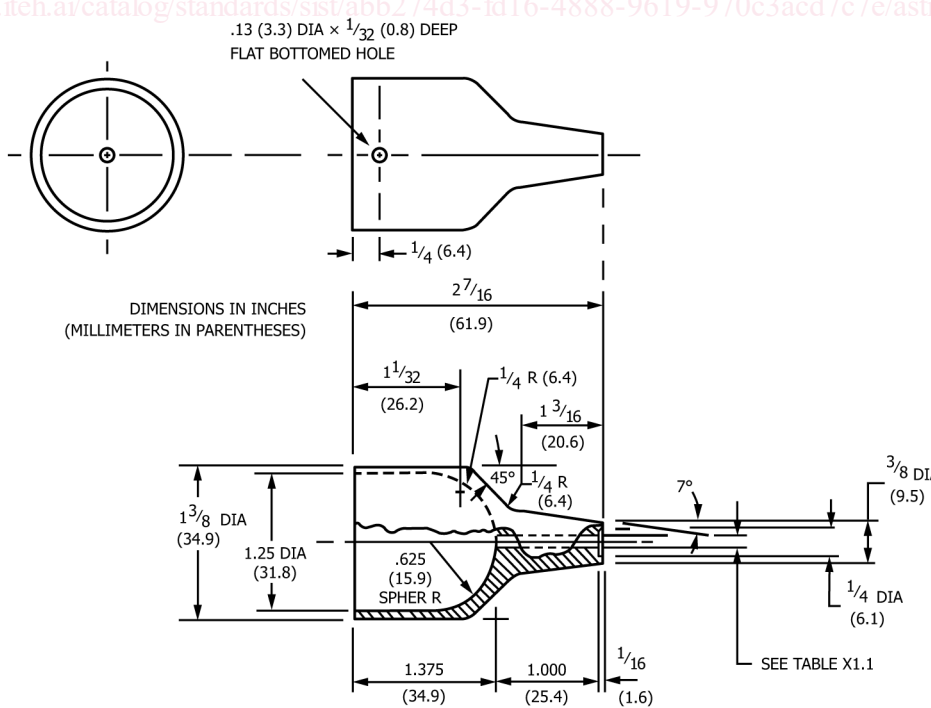

FIG. 2 Shell Cup

³ Shell cups may be obtained from the Norcross Corp., 255 Newtonville Ave., Newton, MA 02158. This committee is not aware of any other source for flow cups having properties similar enough to the Shell cup to be included in this test method. If you have knowledge of a cup that should be considered, please provide details to ASTM International Headquarters. Your comments will receive careful consideration at a meeting of the responsible technical committee,¹ which you may attend.

<https://standards.iteh.ai/catalog/standards/sist/abb274d3-fd16-4888-9619-970c3acd7c7e/astm-d4212-102014>