



Standard Test Method for Stress Cracking of Transparent Plastics¹

This standard is issued under the fixed designation F 791; the number immediately following the designation indicates the year of original adoption or, in the case of revision, the year of last revision. A number in parentheses indicates the year of last reappraisal. A superscript epsilon (ϵ) indicates an editorial change since the last revision or reappraisal.

1. Scope

1.1 This test method covers the determination of the critical crazing stress for a transparent plastic material when exposed to a specific solvent, chemical, or compound at a specific temperature.

1.2 *This standard does not purport to address all of the safety concerns, if any, associated with its use. It is the responsibility of the user of this standard to establish appropriate safety and health practices and determine the applicability of regulatory limitations prior to use.*

2. Referenced Documents

2.1 ASTM Standards:

D 618 Methods of Conditioning Plastics for Testing²

E 691 Practice for Conducting an Interlaboratory Study to Determine the Precision of a Test Method³

2.2 Other Method:

ARTC (Aircraft Research and Testing Committee of the Aircraft Industries Association of America, Inc.) Conditioning Method⁴

3. Terminology

3.1 Definitions of Terms Specific to This Standard:

3.1.1 *crazing*—a group of surface fissures that appear to be small cracks in the material, although they are not.

3.1.1.1 *Discussion*—Crazing is a form of yielding in polymers characterized by a spongy void filled fibrillar structure. The density in the craze changes resulting in a change in the index of refraction, which causes light to be reflected off of the crazes. This light reflection causes the crazes to sparkle when viewed from certain angles. The crazes are sometimes random and scattered with varied lengths and depths but usually are oriented perpendicular to a tensile stress. Crazing may be difficult to detect. It becomes more pronounced when viewed with a light source that is at an oblique angle.

¹ This test method is under the jurisdiction of ASTM Committee F-7 on Aerospace and Aircraft and is the direct responsibility of Subcommittee F07.08 on Transparent Materials and Enclosures.

Current edition approved Oct. 10, 1996. Published December 1996. Originally published as F 791 – 82. Last previous edition F 791 – 82 (1988).

² *Annual Book of ASTM Standards*, Vol 08.01.

³ *Annual Book of ASTM Standards*, Vol 14.02.

⁴ Available from Aircraft Industries Association, 1725 DeSales St. NW, Washington, DC 20034.

4. Significance and Use

4.1 This test method provides a guide for evaluating a specific solvent, chemical, or compound that may be detrimental to a transparent plastic as a result of a manufacturing process, a fabrication operation, or the operational environment. All transparent plastics are susceptible to crazing, though in widely varying degree and from a variety of causes. This test method is intended to allow establishment of the crazing stress when the simultaneous action of both load and a material that would cause crazing is applied producing non-reversible damage that might limit the usage of that transparent plastic in a specific application.

5. Apparatus

5.1 *Test Fixture*, with fluorescent light source illustrated and constructed as shown in Figs. 1 and 2.

5.2 *Drill Fixture* constructed as shown in Fig. 3.

5.3 *Marking Fixture*, constructed as shown in Fig. 3.

5.4 *Portable Specimen Rack*, constructed in the manner as shown in Fig. 4 for handling and conditioning test specimens.

5.5 *Weights*—A container and shot for the application of weight on the rack as shown in Fig. 1.

5.6 *Filter Paper*, quantity of 0.50 by 1.0-in. (12.7 by 25.4-mm) pieces of filter, medium-retention filter paper.

6. Test Specimens

6.1 The test specimen shall be machined from the transparent plastic material to be evaluated. A minimum of six specimens for each solvent, chemical, or compound is required. It is preferred that the transparent plastic sheet material thickness be 6.35 ± 0.64 mm (0.250 ± 0.025 in.), but any thickness material may be used. Orientation of each test specimen within the test sheet or part should be recorded.

6.2 The test specimens shall be 25.4 ± 0.8 mm (1.00 ± 0.03 in.) wide by 177.8 ± 1.27 mm (7.00 ± 0.05 in.) long by thickness.

6.3 The edges shall be smooth machined surfaces without cracks, and the test specimen surface shall be free of defects or irregularities. If the test specimen has been machined to thickness, the nonmachined surface shall be the test surface.

7. Preparation of Apparatus

7.1 Once the load for a particular stress is calculated, that load will be the sum of the individual weights of the weight

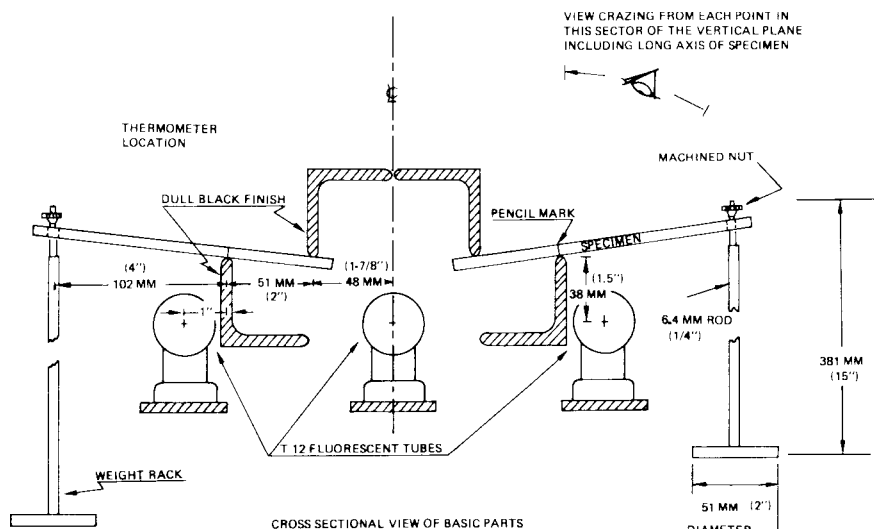

SPECIMEN SUPPORTS: 51 MM x 51 MM x 6.4 MM (2" x 2" x 1/4") ANGLE HAVING 3.2 MM (1/8") RADIUS ON BEARING EDGES. PLANE OF UPPER BEARING EDGES MAY VARY FROM ZERO TO 6.4 MM (1/4") ABOVE PLANE OF FULCRUM BEARING EDGES.

FIG. 1 Accelerated Craze Test Fixture

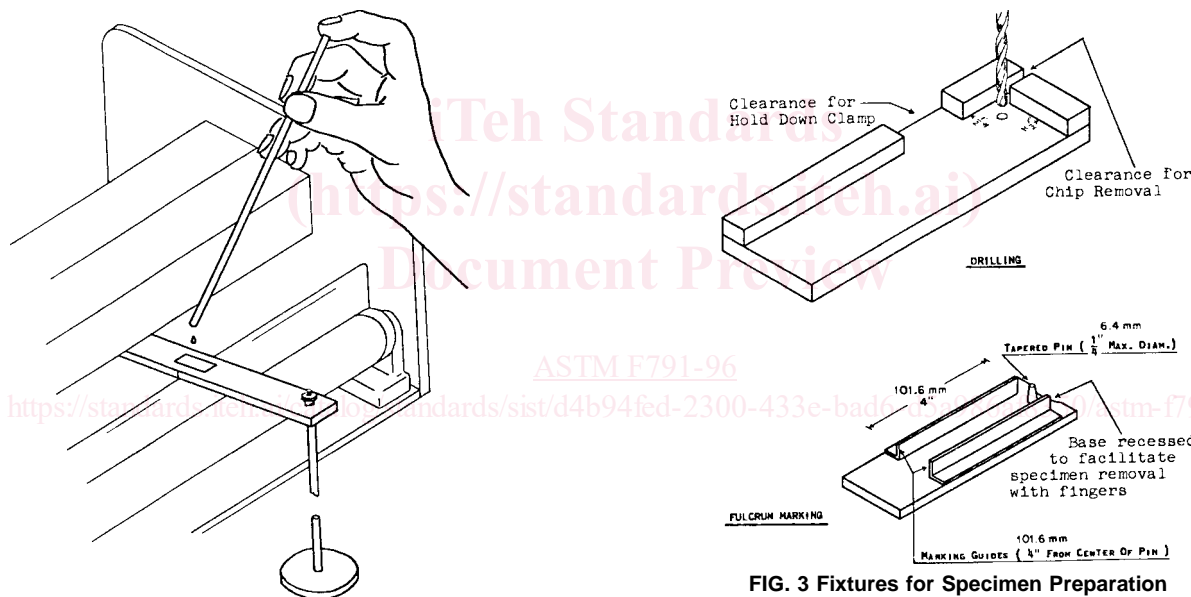

FIG. 2 Application of Test Liquid to Piece of Filter Paper on Top Surface of Test Specimen

FIG. 3 Fixtures for Specimen Preparation

rack, rod, lead weights, container, shot, and the radiused nut. For convenience of assembly, the weight rack pan may be stamped with the total weight of the pan, rod, and nuts as a unit. A container, such as a 1/2-pt (0.24-L) paint can with a 6.4-mm (1/4-in.) hole drilled in the center of the bottom and installed so it slides up and down on the rod, can serve as a receptacle for the lead shot to attain required weight.

8. Conditioning

8.1 Precondition the test specimens in accordance with one of the following procedures:

8.1.1 Practice D 618 Procedure B. Forty-eight hours at 50°C (122°F) followed by cooling to room temperature in desiccator over anhydrous calcium chloride for at least 5 h. Designate as Condition 1 and test within 15 min.

8.1.2 Two hours at 90°C (194°F), ambient cooled, and followed by 7 days at 23 ± 1.1°C (73.5 ± 2°F) and 50 ± 5 % relative humidity. Designate as Condition 2 and test within 1 h.

8.1.3 ARTC Method. Sixteen hours at 14°C (25°F) below the average heat deflection temperature, cool at a rate not exceeding 28°C (50°F)/h and follow by 96 h at 23 ± 1.1°C (73.5 ± 2°F) and 50 ± 5 % relative humidity. Designate as Condition 3 and test within 1 h.

8.1.4 As received, no preconditioning. Designate as Condition 4.

NOTE 1—The conditions listed above may not result in uniform moisture content for certain plastics. Moisture content reportedly may have a strong effect on craze results for certain plastics. If other preconditionings are required to ensure uniform or desired moisture content, the use of these should be reported in the test report.

9. Calculation of Loads

9.1 The width and thickness of each specimen shall be