



Designation: **D5045 – 99 (Reapproved 2007)^{ε1} D5045 – 14**

Standard Test Methods for Plane-Strain Fracture Toughness and Strain Energy Release Rate of Plastic Materials¹

This standard is issued under the fixed designation D5045; the number immediately following the designation indicates the year of original adoption or, in the case of revision, the year of last revision. A number in parentheses indicates the year of last reapproval. A superscript epsilon (ϵ) indicates an editorial change since the last revision or reapproval.

^{ε1} NOTE—Reapproved with editorial changes in March 2007

1. Scope*

1.1 These test methods are designed to characterize the toughness of plastics in terms of the critical-stress-intensity factor, K_{Ic} , and the energy per unit area of crack surface or critical strain energy release rate, G_{Ic} , at fracture initiation.

1.2 Two testing geometries are covered by these test methods, single-edge-notch bending (SENB) and compact tension (CT).

1.3 The scheme used assumes linear elastic behavior of the cracked specimen, so certain restrictions on linearity of the load-displacement diagram are imposed.

1.4 A state-of-plane strain at the crack tip is required. Specimen thickness must be sufficient to ensure this stress state.

1.5 The crack must be sufficiently sharp to ensure that a minimum value of toughness is obtained.

1.6 The significance of these test methods and many conditions of testing are identical to those of Test Method E399, and, therefore, in most cases, appear here with many similarities to the metals standard. However, certain conditions and specifications not covered in Test Method E399, but important for plastics, are included.

1.7 This protocol covers the determination of G_{Ic} as well, which is of particular importance for plastics.

1.8 These test methods give general information concerning the requirements for K_{Ic} and G_{Ic} testing. As with Test Method E399, two annexes are provided which give the specific requirements for testing of the SENB and CT geometries.

1.9 Test data obtained by these test methods are relevant and appropriate for use in engineering design.

1.10 *This standard does not purport to address all of the safety concerns, if any, associated with its use. It is the responsibility of the user of this standard to establish appropriate safety and health practices and determine the applicability of regulatory limitations prior to use.*

NOTE 1—There is currently no ISO standard that duplicates these test methods. Pending ISO/CD 13586 covers similar testing and references this test method for testing conditions. This standard and ISO 13586 address the same subject matter, but differ in technical content.

2. Referenced Documents

2.1 *ASTM Standards:*²

D638 Test Method for Tensile Properties of Plastics

D4000 Classification System for Specifying Plastic Materials

E399 Test Method for Linear-Elastic Plane-Strain Fracture Toughness K_{Ic} of Metallic Materials

E691 Practice for Conducting an Interlaboratory Study to Determine the Precision of a Test Method

3. Terminology

3.1 *Definitions:*

3.1.1 *compact tension, n*—specimen geometry consisting of single-edge notched plate loaded in tension. See 3.1.5 for reference to additional definition.

¹ These test methods are under the jurisdiction of ASTM Committee D20 on Plastics and is the direct responsibility of Subcommittee D20.10 on Mechanical Properties. Current edition approved March 1, 2007/Dec. 1, 2014. Published June 2007/December 2014. Originally approved in 1990. Last previous edition approved in 1999 as D5045 – 99; D5045 – 99(2007)^{ε1}. DOI: 10.1520/D5045-99R07E01.10.1520/D5045-14.

² For referenced ASTM standards, visit the ASTM website, www.astm.org, or contact ASTM Customer Service at service@astm.org. For *Annual Book of ASTM Standards* volume information, refer to the standard's Document Summary page on the ASTM website.

*A Summary of Changes section appears at the end of this standard

3.1.2 *critical strain energy release rate, G_{Ic}* n —toughness parameter based on energy required to fracture. See 3.1.5 for reference to additional definition.

3.1.3 *plane-strain fracture toughness, K_{Ic}* n —toughness parameter indicative of the resistance of a material to fracture. See 3.1.5 for reference to additional definition.

3.1.4 *single-edge notched bend, n* —specimen geometry consisting of center-notched beam loaded in three-point bending. See 3.1.5 for reference to additional definition.

3.1.5 Reference is made to Test Method E399 for additional explanation of definitions.

3.2 *Definitions of Terms Specific to This Standard:*

3.2.1 *yield stress, n* —stress at fracture is used. The slope of the stress-strain curve is not required to be zero. See 7.2 for reference to additional definition.

4. Summary of Test Methods

4.1 These test methods involve loading a notched specimen that has been pre-cracked, in either tension or three-point bending. The load corresponding to a 2.5 % apparent increment of crack extension is established by a specified deviation from the linear portion of the record. The K_{Ic} value is calculated from this load by equations that have been established on the basis of elastic stress analysis on specimens of the type described in the test methods. The validity of the determination of the K_{Ic} value by these test methods depends upon the establishment of a sharp-crack condition at the tip of the crack, in a specimen of adequate size to give linear elastic behavior.

4.2 A method for the determination of G_{Ic} is provided. The method requires determination of the energy derived from integration of the load versus load-point displacement diagram, while making a correction for indentation at the loading points as well as specimen compression and system compliance.

5. Significance and Use

5.1 The property K_{Ic} (G_{Ic}) determined by these test methods characterizes the resistance of a material to fracture in a neutral environment in the presence of a sharp crack under severe tensile constraint, such that the state of stress near the crack front approaches plane strain, and the crack-tip plastic (or non-linear viscoelastic) region is small compared with the crack size and specimen dimensions in the constraint direction. A K_{Ic} value is believed to represent a lower limiting value of fracture toughness. This value ~~may be~~ has been used to estimate the relation between failure stress and defect size for a material in service wherein the conditions of high constraint described above would be expected. Background information concerning the basis for development of these test methods in terms of linear elastic fracture mechanics can be found in Refs (1-5).³

5.1.1 The K_{Ic} (G_{Ic}) value of a given material is a function of testing speed and temperature. Furthermore, cyclic loads ~~can have~~ been found to cause crack extension at K values less than K_{Ic} (G_{Ic}). Crack extension under cyclic or sustained load will be increased by the presence of an aggressive environment. Therefore, application of K_{Ic} (G_{Ic}) in the design of service components should be made considering differences that may exist between laboratory tests and field conditions.

5.1.2 Plane-strain fracture toughness testing is unusual in that sometimes there ~~can be~~ is no advance assurance that a ~~valid~~ valid K_{Ic} (G_{Ic}) will be determined in a particular test. Therefore it is essential that all of the criteria concerning validity of results be carefully considered as described herein.

5.1.3 Clearly, it will not be possible to determine K_{Ic} (G_{Ic}) if any dimension of the available stock of a material is insufficient to provide a specimen of the required size.

5.2 Inasmuch as the fracture toughness of plastics is often dependent on specimen process history, that is, injection molded, extruded, compression molded, etc., the specimen crack orientation (parallel or perpendicular) relative to any processing direction ~~should~~ shall be noted on the report form discussed in 10.1.

5.3 ~~For many materials, there may be a specification that requires the use of these test methods, but with some procedural modifications that take precedence when adhering to the specification. Therefore, it is advisable to refer to that material specification before using these test methods. Table 1 of Classification System~~ Before proceeding with this test method, reference should be made to the specification of the material being tested. Any test specimen preparation, conditioning, dimensions, or testing ~~D4000 lists the ASTM materials standards that currently exist; parameters, or combination thereof, covered in the relevant ASTM materials specification shall take precedence over those mentioned in this test method. If there are no relevant ASTM material specifications, then the default conditions apply.~~

6. Apparatus

6.1 *Testing Machine*—A constant displacement-rate device shall be used such as an electromechanical, screw-driven machine, or a closed loop, feedback-controlled servohydraulic load frame. For SENB, a rig with either stationary or moving rollers of sufficiently large diameter to avoid excessive plastic indentation is required. A suitable arrangement for loading the SENB

³ The boldface numbers in parentheses refer to the list of references at the end of these test methods.

specimen is that shown in Fig. 1. A loading clevis suitable for loading compact tension specimens is shown in Fig. 2. Loading is by means of pins in the specimen holes (Fig. 3(b)).

6.2 *Displacement Measurement*—An accurate displacement measurement must be obtained to assure accuracy of the G_{Ic} value.

6.2.1 *Internal Displacement Transducer*—For either SENB or CT specimen configurations, the displacement measurement shall be performed using the machine’s stroke (position) transducer. The fracture-test-displacement data must be corrected for system compliance, loading-pin penetration (brinelling) and specimen compression by performing a calibration of the testing system as described in 9.2.

6.2.2 *External Displacement Transducer*—If an internal displacement transducer is not available, or has insufficient precision, then an externally applied displacement-measuring device shall be used as illustrated in Fig. 1 for the SENB configuration. For CT specimens, a clip gauge shall be mounted across the loading pins. For both the SENB and CT specimens, specimens measure the displacement should be taken at the load point.

7. Specimen Size, Configurations, and Preparation

7.1 *Specimen Size:*

7.1.1 SENB and CT geometries are recommended over other configurations because these have predominantly bending stress states which allow smaller specimen sizes to achieve plane strain. Specimen dimensions are shown in Fig. 3 (a, b). If the material is supplied in the form of a sheet, the specimen thickness, B , ~~should be is~~ identical with the sheet thickness, in order to maximize this dimension. The specimen width, W , is $W = 2B$. In both geometries the crack length, a , ~~should shall~~ be selected such that $0.45 < a/W <= 0.55$.

7.1.2 In order for a result to be considered valid according to these test methods, the following size criteria must be satisfied:

$$B, a, (W - a) > 2.5 (K_Q / \sigma_y)^2 \tag{1}$$

where:

- K_Q = the conditional or trial K_{Ic} value (see Section 9), and
- σ_y = the yield stress of the material for the temperature and loading rate of the test.

The criteria require that B must be sufficient to ensure plane strain and that $(W - a)$ be sufficient to avoid excessive plasticity in the ligament. If $(W - a)$ is too small and non-linearity in loading occurs, then increasing the ~~W/B ratio~~ ratio to a maximum of 4 ~~shall be is~~ permitted for SENB specimens.

7.2 *Yield Stress:*

7.2.1 The yield stress, σ_y , is to be taken from the maximum load in a uniaxial tensile test. The yield-stress test can be performed in a constant stroke-rate uniaxial tensile test where the loading time to yield is within $\pm 20\%$ of the actual loading time observed in the fracture test. The definition of yield stress is not identical to that found in Test Method D638 which requires a zero slope to the stress-strain curve. If it is established that $2.5 (K_Q / \sigma_y)^2$ is substantially less than the specimen thickness employed, then a correspondingly smaller specimen can be used.

7.2.2 Yielding in tensile tests in most polymers can be achieved by carefully polishing the specimen sides. If yielding does not occur and brittle fracture is observed, the stress at fracture shall be used in the criteria to give a conservative size value.

7.2.3 If a tensile test cannot be performed, then an alternative method is to use 0.7 times the compressive yield stress.

7.2.4 If the form of the available material is such that it is not possible to obtain a specimen with both crack length and thickness greater than $2.5 (K_{Ic} / \sigma_y)^2$, it is not possible to make a valid $K_{Ic} (G_{Ic})$ measurement according to these test methods.

7.2.5 The test method employed for determining yield stress, as mentioned in 7.2.1 – 7.2.4, must be reported.

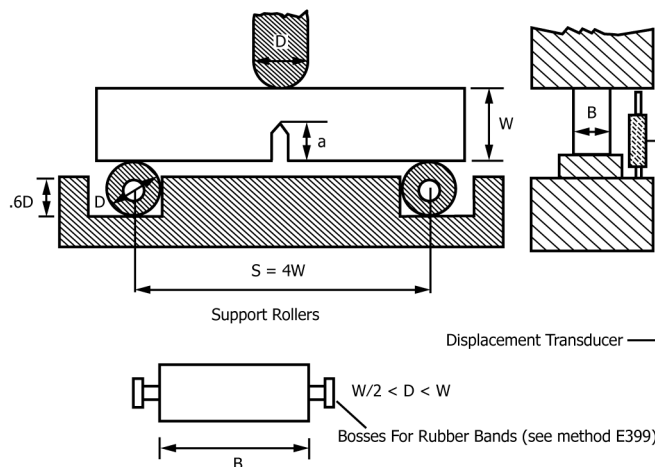

FIG. 1 Bending Rig with Transducer for SENB

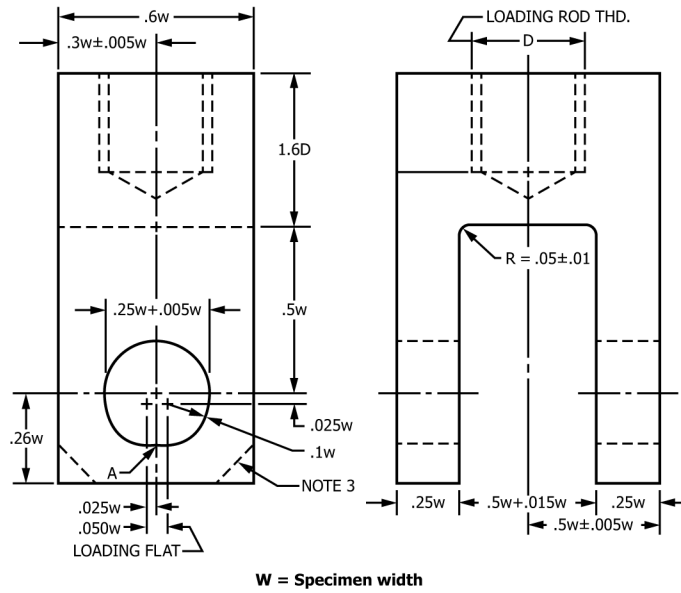

FIG. 2 Tension Testing Clevis Design for CT

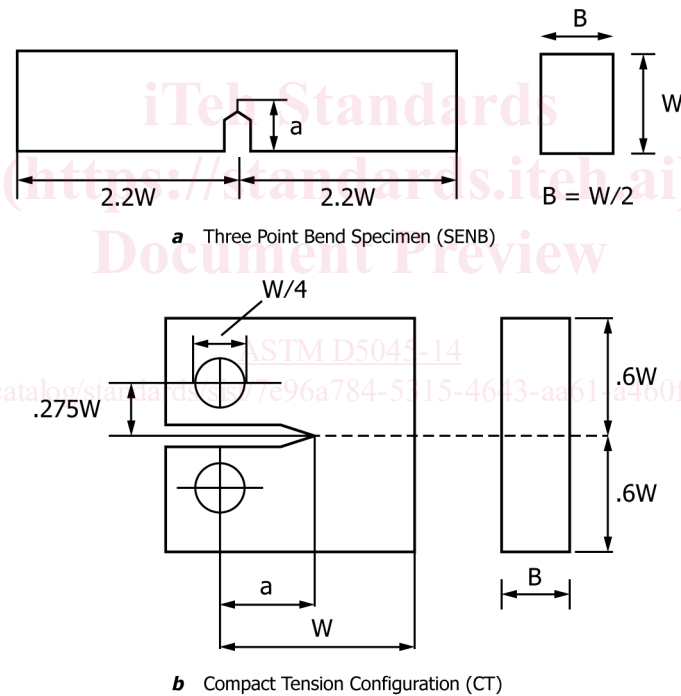

FIG. 3 Specimen Configuration as in Test Method E399

7.3 Specimen Configurations:

7.3.1 *Standard Specimens*—The configurations of the two geometries are shown in Fig. 3(a) (SENB) and Fig. 3(b) (CT), which are taken from Annexes A3 and A4, respectively, of Test Method E399. The crack length, a (crack + crack pre-notch plus razor notch), is nominally equal to the thickness, B , and is between 0.45 and 0.55 times the width, W . The ratio W/B is nominally equal to two.

7.3.2 *Alternative Specimens*—In certain cases it may be desirable to use specimens having W/B ratios other than two. Alternative proportions for bend specimens are $2 < W/B < 4$. This alternative shall have the same a/W and S/W ratios as the standard specimens (S = support span).

7.3.3 *Displacement Correction Specimens*—Separately prepared unnotched specimen configurations for the determination of the displacement correction mentioned in 9.2 are shown in Fig. 4(a) for SENB and in Fig. 4(b) for CT configurations, respectively.

7.4 Specimen Preparation:

a) Single edge notch bend

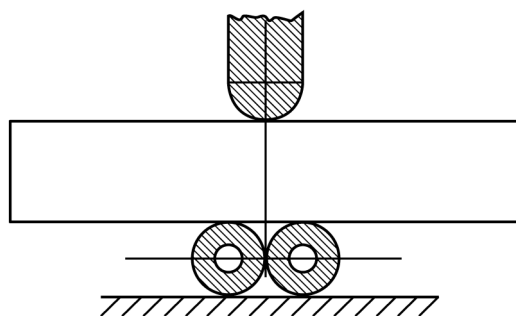

b) Compact Tension

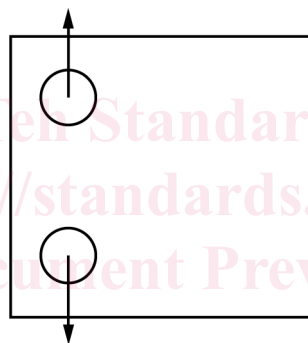

FIG. 4 Arrangements for Finding Indentation Displacement

7.4.1 Initially, prepare a sharp notch by machining. Subsequently, initiate a natural crack by inserting a fresh razor blade and tapping. If a natural crack cannot be successfully initiated by tapping, a sufficiently sharp crack shall alternatively be generated by sliding or sawing a new razor blade across the notch root. The procedure is given in 7.4.1.1 – 7.4.1.5.

7.4.1.1 Machine or saw a sharp notch in the specimen and generate a natural crack by tapping on a fresh razor blade placed in the notch.

7.4.1.2 The depth of the natural crack generated by tapping must be at least two times longer than the width of the sawed-in slot or the machined notch tip radius (notch diagram in Fig. 3 is not to scale).

7.4.1.3 If a natural crack cannot be successfully generated, either because the specimen fractures during tapping, as in some brittle materials, or because a crack cannot be seen, as in some tough materials, then a fresh razor blade can be slid in one motion, in one motion or with a sawing motion slide a fresh razor blade across the machined notch.

7.4.1.4 The depth of the razor notch generated by sliding the razor blade must be two times longer than the width of the sawed-in slot or of the pre-notch tip radius (the notch diagram in Fig. 3 is not to scale).

NOTE 2—Pressing the blade into the notch is not recommended for more ductile resins because it may induce residual stresses at the crack tip which may result in an artificially high value of K_{Ic} .

7.4.1.5 ~~The~~The total depth of the notch obtained by machining and generation of the natural crack is the crack length, a .

8. General Procedure

8.1 *Number of Tests*—It is recommended that at least three replicate tests be made for each material condition.

8.2 *Specimen Measurement*—Specimen dimensions shall conform to those shown in Fig. 3(a, b). Three fundamental measurements are necessary for the calculation of K_{Ic} and G_{Ic} , namely, the thickness, B , the crack length, a , and the width W .

8.2.1 Measure the thickness, B , to 0.1 % accuracy at not less than three positions. ~~The~~Record the average of these three measurements ~~should be recorded as~~ B .

8.2.2 Measure the crack length a , after fracture to the nearest 0.5 % accuracy at the following three positions: at the center of the crack front, and the end of the crack front on each surface of the specimen. Use the average of these three measurements as the crack length, a .

8.2.3 Measure the width, W , to within 0.1 % as described in the annex appropriate to the specimen type being tested.

8.3 Loading Rate:

8.3.1 Since plastics are viscoelastic materials, it is necessary to specify both the temperature and time scale under which the result was obtained. As a basic test condition it is recommended that a temperature of 23°C, and a crosshead rate of 1.67×10^{-4} m/s (10 mm/min) be used. ~~Both Record both~~ loading rate and loading time ~~should be noted~~ on the report form.

NOTE 3—If it is not possible to obtain valid results at 23°C, it is often possible to do so by decreasing the temperature which usually does not change K_{Ic} greatly but increases the yield stress, rendering the fracture more brittle.

8.3.2 It is recommended that speeds greater than 1 m/s or loading times less than 1 ms should be avoided because of the risk of dynamic effects causing errors.

8.4 Loading—The test is performed and the load versus loading-point displacement curve obtained. In the ideal case this is a linear diagram with an abrupt drop of load to zero at the instant of crack growth initiation. In some cases this occurs and K_Q shall be determined from the maximum load.

8.5 Load-Displacement Area—A procedure for determining G_{Ic} is included in 9.3. This requires an accurate integration of the load versus loading point displacement curve, which necessitates an accurate displacement determination using a displacement transducer. A cross check on the accuracy of G_{Ic} is provided through a corrected compliance.

9. Calculation and Interpretation of Results

9.1 Interpretation of Test Record and Calculation of K_Q —In order to establish that a valid K_{Ic} has been determined, it is first necessary to calculate a conditional result, K_Q , which involves a construction on the test record, and to then determine whether this result is consistent with the size of the specimen in accordance with 9.1.3. The procedure is given in 9.1.1 – 9.1.5.

9.1.1 Load the specimen and obtain a diagram as shown in Fig. 5. Draw a best straight line (AB) to determine the initial compliance, C . C is given by the reciprocal of the slope of line (AB). Draw a second line (AB') with a compliance 5 % greater than that of line (AB). If the maximum load that the specimen was able to sustain, P_{max} , falls within lines (AB) and (AB'), use P_{max} to calculate K_Q . If P_{max} falls outside line (AB) and line (AB'), then use the intersection of line (AB') and the load curve as P_Q . Furthermore, if $P_{max}/P_Q < 1.1$, use P_Q in the calculation of K_Q . However, if $P_{max}/P_Q > 1.1$, the test is invalid.

9.1.2 Calculate K_Q in accordance with the procedure given in A1.4 for SENB and A2.5 for CT. For this calculation, a value of a , which is the total crack length after both notching and pre-cracking, but before fracture, is best determined from the fracture surface after testing. An average value is used, but the difference between the shortest and longest length should not exceed 10 %. Take care that it is the original crack which is being observed, since slow growth can occur prior to catastrophic fast fracture.

9.1.3 Check the validity of K_Q via the size criteria. Calculate $2.5 (K_Q/\sigma_y)^2$ where σ_y is the yield stress discussed in 7.2.1. If this quantity is less than the specimen thickness, B , the crack length, a , and the ligament ($W - a$), K_Q is equal to K_{Ic} . Otherwise the test is not a valid K_{Ic} test.

NOTE 4—Note that use of a specimen with too small a thickness, B , will result in K_Q being higher than the true K_{Ic} value while a small ($W - a$) will

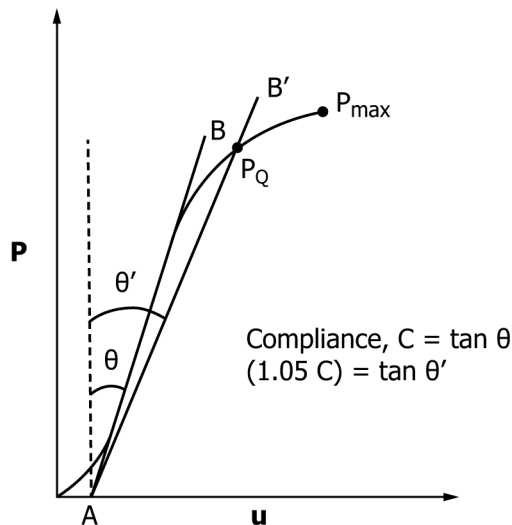

NOTE 1— C is the inverse slope of line AB.

FIG. 5 Determination of C and P_Q