



Designation: D635 – 14

# Standard Test Method for Rate of Burning and/or Extent and Time of Burning of Plastics in a Horizontal Position<sup>1</sup>

This standard is issued under the fixed designation D635; the number immediately following the designation indicates the year of original adoption or, in the case of revision, the year of last revision. A number in parentheses indicates the year of last reapproval. A superscript epsilon ( $\epsilon$ ) indicates an editorial change since the last revision or reapproval.

*This standard has been approved for use by agencies of the U.S. Department of Defense.*

## 1. Scope\*

1.1 This fire-test-response test method covers a small-scale laboratory screening procedure for comparing the relative linear rate of burning or extent and time of burning, or both, of plastics in the form of bars, molded or cut from sheets, plates, or panels, and tested in the horizontal position.

NOTE 1—This test method, and test method A of IEC 60695-11-10 are technically equivalent.

NOTE 2—For additional information on materials which do not burn to the first reference mark by this test, see Test Method D3801.

1.2 This test method was developed for polymeric materials used for parts in devices and appliances. The results are intended to serve as a preliminary indication of their acceptability with respect to flammability for a particular application. The final acceptance of the material is dependent upon its use in complete equipment that conforms with the standard applicable to such equipment.

1.3 The classification system described in Appendix X1 is intended for quality assurance and the preselection of component materials for products.

1.4 The values stated in SI units are to be regarded as standard. No other units of measurement are included in this standard.

1.5 *This standard is used to measure and describe the response of materials, products, or assemblies to heat and flame under controlled conditions, but does not by itself incorporate all factors required for fire hazards or fire risk assessment of materials, products, or assemblies under actual fire conditions.*

1.6 *This standard does not purport to address all of the safety concerns, if any, associated with its use. It is the responsibility of the user of this standard to establish appropriate safety and health practices and determine the applica-*

*bility of regulatory limitations prior to use. For specific hazards statements, see 9.2.*

## 2. Referenced Documents

### 2.1 ASTM Standards:<sup>2</sup>

- D618 Practice for Conditioning Plastics for Testing
- D648 Test Method for Deflection Temperature of Plastics Under Flexural Load in the Edgewise Position
- D883 Terminology Relating to Plastics
- D1929 Test Method for Determining Ignition Temperature of Plastics
- D2843 Test Method for Density of Smoke from the Burning or Decomposition of Plastics
- D3801 Test Method for Measuring the Comparative Burning Characteristics of Solid Plastics in a Vertical Position
- D5025 Specification for Laboratory Burner Used for Small-Scale Burning Tests on Plastic Materials
- D5207 Practice for Confirmation of 20-mm (50-W) and 125-mm (500-W) Test Flames for Small-Scale Burning Tests on Plastic Materials
- E84 Test Method for Surface Burning Characteristics of Building Materials
- E176 Terminology of Fire Standards
- E691 Practice for Conducting an Interlaboratory Study to Determine the Precision of a Test Method

### 2.2 IEC Standards:<sup>3</sup>

- IEC 60695-11-10 Fire Hazard Testing—Part 11-10 Test Flames—50W Horizontal and Vertical Flame Test Methods

## 3. Terminology

### 3.1 Definitions:

<sup>2</sup> For referenced ASTM standards, visit the ASTM website, www.astm.org, or contact ASTM Customer Service at service@astm.org. For *Annual Book of ASTM Standards* volume information, refer to the standard's Document Summary page on the ASTM website.

<sup>3</sup> Publications of the International Electrotechnical Commission (IEC) and International Organization for Standardization (ISO) are available from American National Standards Institute (ANSI), 25 W. 43rd St., 4th Floor, New York, NY 10036.

<sup>1</sup> This test method is under the jurisdiction of ASTM Committee D20 on Plastics and is the direct responsibility of Subcommittee D20.30 on Thermal Properties (Section D20.30.03).

Current edition approved Dec. 1, 2014. Published December 2014. Originally approved in 1941. Last previous edition approved in 2010 as D635 – 10. DOI: 10.1520/D0635-14.

\*A Summary of Changes section appears at the end of this standard

3.1.1 Definitions used in this test method are in accordance with Terminology **D883**, unless otherwise specified. For terms relating to fire, the definitions used in this test method are in accordance with Terminology **E176**.

#### 4. Summary of Test Method

4.1 A bar specimen of the material to be tested is supported horizontally at one end. The free end is exposed to a specified gas flame for 30 s. Time and extent of burning are measured and reported if the specimen does not burn 100 mm. An average burning rate is reported for a material if it burns to the 100 mm mark from the ignited end.

#### 5. Significance and Use

5.1 Tests made on a material under conditions herein prescribed are of value in comparing the rate of burning or extent and time of burning characteristics, or both, of different materials, in controlling manufacturing processes, or as a measure of deterioration or change in these burning characteristics prior to or during use. Correlation with flammability under actual use conditions is not implied.

5.2 The rate of burning and other burning phenomena will be affected by such factors as density, pigments, any anisotropy of the material and the thickness of the specimen. Test data shall be compared only for specimens of similar thickness, whether comparisons are being made with the same or different materials. The rate of burning and other burning phenomena will vary with thickness.

5.3 It is feasible that sheet materials that have been stretched during processing will relax during burning and give erratic results unless they are first heated above their deflection temperature, in accordance with Test Method **D648**, for a time sufficient to permit complete relaxation.

5.4 Burning tests require that certain variables be arbitrarily fixed, for example, specimen size, energy source and application time, and end points. Materials will be found that are unusually sensitive to one or more of the conditions chosen for this method leading to highly variable results. Additional burning characterization by other methods is highly desirable in such cases (see **Note 2**).

5.5 In this procedure, the specimens are subjected to specific laboratory test conditions. If different test conditions are substituted or the end-use conditions are changed, it will not always be possible by or from this test to predict changes in the fire-test-response characteristics measured. Therefore, the results are valid only for the fire-test-exposure conditions described in this procedure.

#### 6. Apparatus

6.1 *Test Chamber*, enclosed laboratory hood, or chamber free of induced or forced draft during test, having an inside volume of at least 0.5 m<sup>3</sup>. An enclosed laboratory hood with a heat-resistant glass window for observing the test and an exhaust fan for removing the products of combustion after the tests is recommended. The atmosphere in and around the test chamber shall be maintained between 15 to 35°C and ≤75 % relative humidity.

**NOTE 3**—The amount of oxygen available to support combustion is naturally important for the conduct of these fire-test-response tests. For tests conducted by this test method when burning times are protracted, chamber sizes less than 1 m<sup>3</sup> may not provide accurate results.

**NOTE 4**—Some laboratory hoods have induced drafts even with the exhaust fan off. A positive-closing damper is recommended.

**NOTE 5**—A mirror in the chamber, to provide a rear view of the specimen, has been found useful in some enclosures.

6.2 *Test Fixture*, A laboratory ring stand or test fixture equipped with a means of holding a 125 mm<sup>2</sup> wire gauze horizontal and a small clamp permitting the specimen to be held with its longitudinal axis horizontal and its transverse axis inclined at 45 ± 2° angle as illustrated in **Fig. 1**.

**NOTE 6**—A pan of water may be placed on the floor of the hood in position to catch any burning particles that may drop during the test.

6.3 *Laboratory Burner*, constructed in accordance with Specification **D5025**.

6.4 *Gas Supply*, a supply of technical-grade methane gas with suitable regulator and meter for uniform gas flow. Natural gas mixtures having an energy density of approximately 37 MJ/m<sup>3</sup> have been found to provide similar results. However, technical-grade methane gas shall be used as the referee in cases of dispute.

6.5 *Wire Gauze*, 20-mesh (approximately 20 openings per 25 mm), made with 0.43 ± 0.03 mm diameter iron wire cut to approximately 125 mm<sup>2</sup>, to sustain burning or glowing particles falling from the specimens.

6.6 *Timing Device*, accurate to 0.5 s.

6.7 *Scale*, graduated in millimetres.

6.8 *Micrometer*, accurate to 0.05 mm.

6.9 *Conditioning Room or Chamber*, capable of being maintained at 23 ± 2°C and 50 ± 10 % relative humidity.

6.10 *Flexible Specimen Support Fixture*, used to facilitate the testing of specimens that sag and touch the wire gauze. (See **9.4** and **Fig. 2**.)

#### 7. Test Specimens

7.1 All test specimens shall be cut from a representative sample of the material (sheet or end products), or shall be cast or injection-, compression-, transfer- or pultrusion-molded to the necessary form. After any cutting operation, care shall be taken to remove all dust and any particles from the surface; cut edges shall be fine sanded to have a smooth finish. Unless otherwise agreed, fabrication of test specimens shall be in accordance with the specifications of the material being tested.

7.2 Specimens shall be 125 ± 5 mm long by 13.0 ± 0.5 mm wide, and provided in the minimum thickness and in the 3.0 (−0.0 +0.2) mm thickness. The 3.0 mm thick specimens are not necessary if the minimum thickness is greater than 3.0 mm, or the maximum thickness is less than 3.0 mm. The maximum thickness shall not exceed 13 mm. The maximum width shall not exceed 13.5 mm. The edges shall be smooth, and the radius on the corners shall not exceed 1.3 mm.

7.3 It is possible that the results of tests carried out on test specimens of different colors, thicknesses, densities, molecular

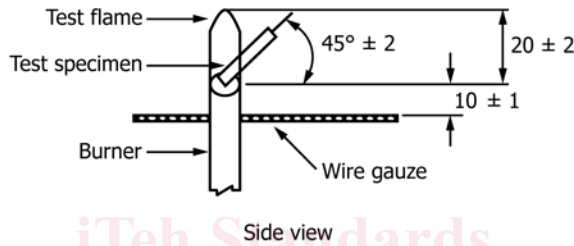
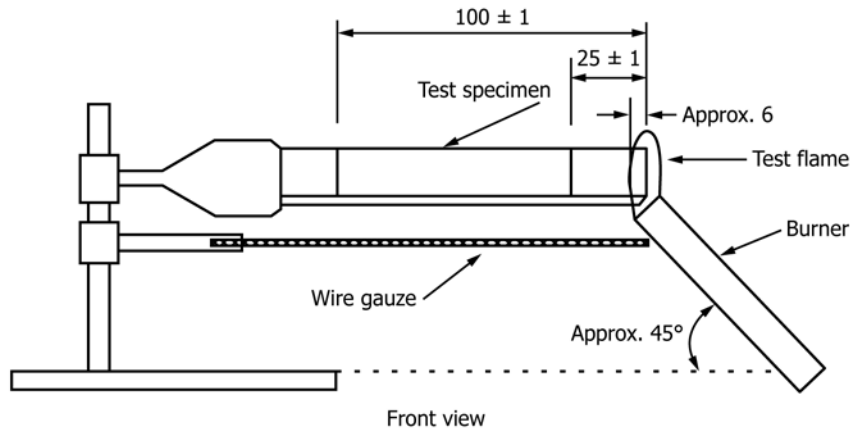

Dimensions in millimetres

FIG. 1 Test Fixture

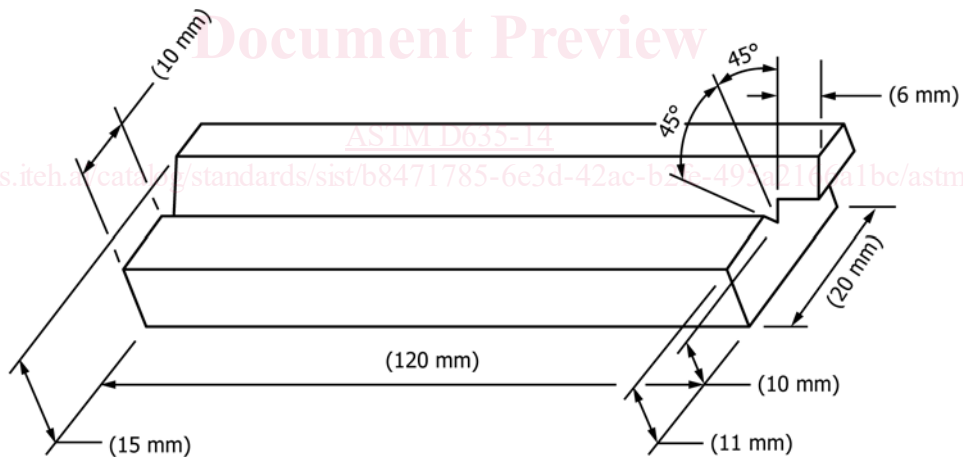

FIG. 2 Flexible Specimen Support Fixture

masses, directions of anisotropy and types, or with different additives, fillers/reinforcements will be different.

7.3.1 Test specimens in the minimum and maximum densities, melt flows and level of fillers/reinforcements contents shall be considered representative of the range, if the results yield the same flame test classification. If the burning characteristics are not essentially the same for all specimens representing the range, the evaluation is to be limited only to the materials in the densities, melt flows, and fillers/reinforcements contents tested. Additional specimens in the

intermediate densities, melt flows, and fillers/reinforcements contents are to be tested.

7.3.2 Uncolored test specimens and test specimens with the highest level of organic and inorganic pigment loading by weight are considered representative of the color range, if the test results are essentially the same. When certain pigments are known to affect flammability characteristics, they are also to be tested. Specimens to be tested are those that:

- (a) contain no coloring
- (b) contain the highest level of organic pigments