



Designation: **D746 – 13 D746 – 14**

Standard Test Method for Brittleness Temperature of Plastics and Elastomers by Impact¹

This standard is issued under the fixed designation D746; the number immediately following the designation indicates the year of original adoption or, in the case of revision, the year of last revision. A number in parentheses indicates the year of last reapproval. A superscript epsilon (ϵ) indicates an editorial change since the last revision or reapproval.

This standard has been approved for use by agencies of the U.S. Department of Defense.

1. Scope*

1.1 This test method covers the determination of the temperature at which plastics and elastomers (as defined by Terminology **D883**) exhibit brittle failure under specified impact conditions. Two routine inspection and acceptance procedures are also provided.

NOTE 1—When testing rubbers for impact brittleness use Test Method **D2137**. When testing plastic sheeting for impact brittleness, use Test Method **D1790**.

1.2 The values stated in SI units are to be regarded as the standard.

1.3 Due to the potential safety and environmental hazards associated with mercury-filled thermometers, the use of alternative temperature measuring devices (such as thermocouples and RTDs) is encouraged.

1.4 *This standard does not purport to address all of the safety concerns, if any, associated with its use. It is the responsibility of the user of this standard to establish appropriate safety and health practices and determine the applicability of regulatory limitations prior to use.*

NOTE 2—This test method and ISO 974 address the same subject matter, but differ in technical content.

2. Referenced Documents

2.1 *ASTM Standards:*²

D618 Practice for Conditioning Plastics for Testing

D832 Practice for Rubber Conditioning For Low Temperature Testing

D883 Terminology Relating to Plastics

D1790 Test Method for Brittleness Temperature of Plastic Sheet by Impact

D2137 Test Methods for Rubber Property—Brittleness Point of Flexible Polymers and Coated Fabrics

E1 Specification for ASTM Liquid-in-Glass Thermometers

E77 Test Method for Inspection and Verification of Thermometers

E608/E608M Specification for Mineral-Insulated, Metal-Sheathed Base Metal Thermocouples

E1137/E1137M Specification for Industrial Platinum Resistance Thermometers

2.2 *ISO Standard:*

ISO 974 Plastics—Determination of the Brittleness Temperature by Impact³

2.3 *ASTM Adjuncts:*

Detailed Drawing of a Typical Clamp⁴

3. Terminology

3.1 *General*—The definitions of plastics used in this test method are in accordance with Test Method **D883** unless otherwise specified.

¹ This test method is under the jurisdiction of ASTM Committee **D20** on Plastics and is the direct responsibility of Subcommittee **D20.30** on Thermal Properties.30.07). Current edition approved June 1, 2013Dec. 1, 2014. Published June 2013December 2014. Originally approved in 1943. Last previous edition approved in 20072013 as **D746 – 07:D746 – 13**. DOI: 10.1520/D0746-13.10.1520/D0746-14.

² For referenced ASTM standards, visit the ASTM website, www.astm.org, or contact ASTM Customer Service at service@astm.org. For *Annual Book of ASTM Standards* volume information, refer to the standard's Document Summary page on the ASTM website.

³ *ISO Standards Handbook 21*, Vol 1. ISO Standards are available from American National Standards Institute (ANSI), 25 W. 43rd St., 4th Floor, New York, NY 10036.

⁴ A detailed drawing of a typical clamp may be obtained from ASTM Headquarters. Order Adjunct : **ADJD0746**.

*A Summary of Changes section appears at the end of this standard

3.2 *brittleness temperature*—that temperature, estimated statistically, at which 50 % of the specimens would probably fail.

3.3 *failed specimen*—the division of a specimen into two or more completely separated pieces or as any crack in the specimen which is visible to the unaided eye.

4. Summary of Test Method

4.1 To determine the brittleness temperature, specimens are secured to a specimen holder using a torque wrench. The specimen holder is immersed in a bath containing a heat-transfer medium, which has been cooled. The specimens are struck at a specified linear speed and then examined for failures. The brittleness temperature is defined as the temperature at which 50 % of the specimens would probably fail.

5. Significance and Use

5.1 This test method establishes the temperature at which 50 % of the specimens tested would probably fail when subjected to the conditions specified herein. The test provides for the evaluation of long-time effects such as crystallization, or those effects that are introduced by low-temperature incompatibility of plasticizers in the material under test. Plastics and elastomers are used in many applications requiring low-temperature flexing with or without impact. Use data obtained by this method to predict the behavior of plastic and elastomeric materials at low temperatures only in applications in which the conditions of deformation are similar to those specified in this test method. This test method has been found useful for specification purposes, but does not necessarily measure the lowest temperature at which the material is suitable for use.

6. Apparatus

6.1 *Specimen Clamp and Striking Edge:*

6.1.1 *Type A:*

6.1.1.1 Design the specimen clamp to hold the specimen or specimens as a cantilever beam. Each individual specimen shall be firmly and securely held in a separate clamp. The striking edge shall be hardened-steel, have a radius of 1.6 ± 0.1 mm and shall move relative to the specimens at a linear speed of 2000 ± 200 mm/s at impact and during at least the following 6.4 mm of travel. In order to maintain this speed on some instruments, it is necessary to reduce the number of specimens tested at one time. The distance between the center line of the striking edge and the clamp shall be 7.87 ± 0.25 mm at impact. The striking edge and specimen clamp shall have a clearance of 6.35 ± 0.25 mm at and immediately following impact. These dimensional requirements are illustrated in Fig. 1. Fig. 2 shows a typical clamp.⁴ Use free-fitting clamping screws, 10-32 National Fine Thread.

6.1.2 *Type B:*

6.1.2.1 Design the specimen clamp to hold the specimen or specimens as a cantilever beam. Each individual specimen shall be firmly and securely held in a separate clamp. The striking edge shall be hardened-steel, have a radius of 1.6 ± 0.1 mm, and shall move relative to the specimens at a linear speed of 2000 ± 200 mm/s at impact and during at least the following 5.0 mm of travel. In order to maintain this speed on some instruments, it is necessary to reduce the number of specimens tested at one time. The radius of the lower jaw of the clamp shall be 4.0 ± 0.1 mm. The striking edge and specimen clamp shall have a clearance of 3.6 ± 0.1 mm at and immediately following impact. The clearance between the outside of the striking edge and the clamp shall be 2.0 ± 0.1 mm at impact. These dimensional requirements of the striking edge and clamping device are illustrated in Fig. 3. Fig. 4 shows a typical clamp. Details of the specimen clamp are given in Fig. 5.

6.2 *Torque Wrench*, 0 to 8.5 N · m.

NOTE 3—Because of the difference in geometry of the specimen clamps, test results obtained when using the Type A specimen clamp and striking member may not correlate with those results obtained when using the Type B apparatus.

6.3 *Temperature-Measurement System*—The temperature of the heat-transfer medium shall be determined with a temperature measuring device (for example, thermocouple, resistance thermometer, or liquid-in-glass thermometer) having a suitable range for the temperatures at which the determinations are to be made. The temperature-measuring device and the related readout equipment

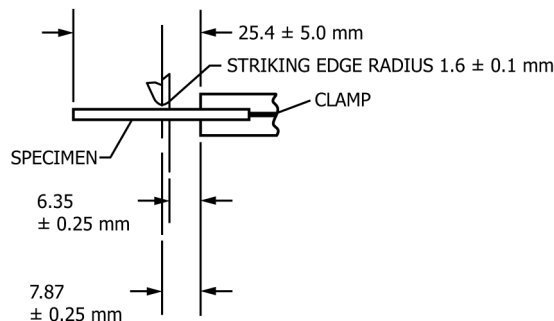

FIG. 1 Dimensional Requirements Between Specimen Clamp and Striking Edge (Type A)

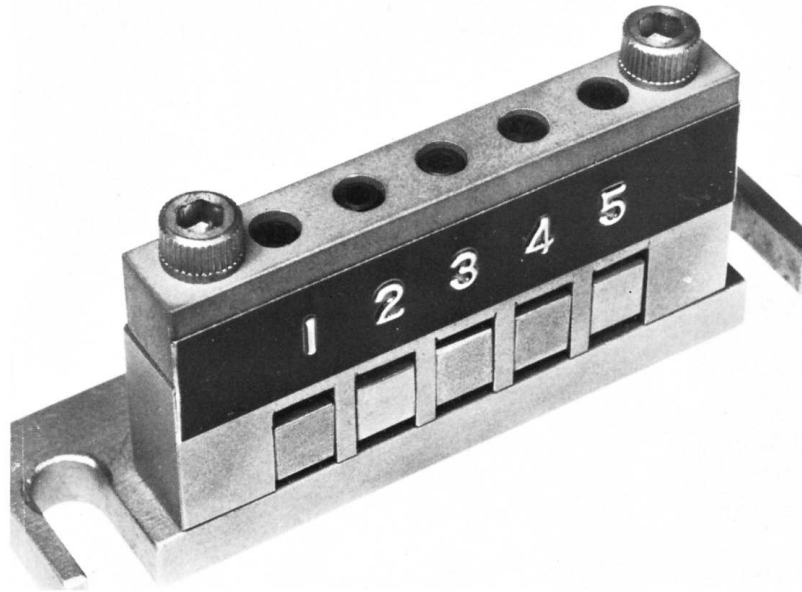
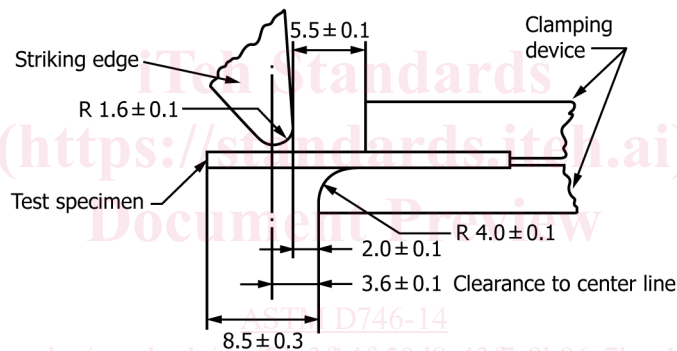

FIG. 2 Typical Clamp (Type A)



NOTE 1—Dimensions are in millimetres.

FIG. 3 Dimensional Details of Striking Edge and Clamping Device, Type B (Positioning of Unnotched Test Specimen)

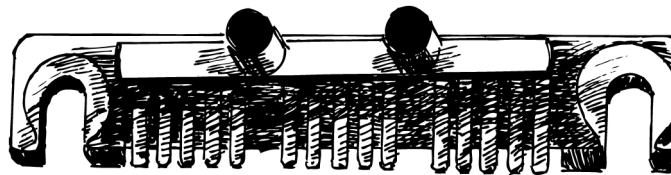

FIG. 4 Assembled Clamp with Test Specimens, Type B

shall be accurate to at least $\pm 0.5^\circ\text{C}$. The temperature-measuring device shall be located as close to the specimens as possible. Thermocouples shall conform to the requirements of Specification E608/E608M. Resistance temperature devices shall comply with the requirements of Specification E1137/E1137M. Liquid-in-glass thermometers, are described in Specification E1. Use the thermometer appropriate for the temperature range and accuracy required, and calibrate it for the appropriate immersion depth in accordance with Test Method E77.

6.4 *Heat-Transfer Medium*—Use any liquid heat transfer medium that remains fluid at the test temperature and does not appreciably affect the material being tested. Measurement of selected physical properties prior to and after 15-min exposure at the highest temperature used will provide an indication of the inertness of a plastic to the heat transfer medium.

6.4.1 Where a flammable or toxic solvent is used as the cooling medium, follow customary precautions when handling such materials. Methanol is the recommended heat transfer medium for rubber.

NOTE 4—The following materials have been found suitable for use at the indicated temperatures. When silicone oil is used, moisture from the air will condense on the surface of the oil, causing slush to form. If slush collects on the temperature-measuring device as ice, it will affect temperature

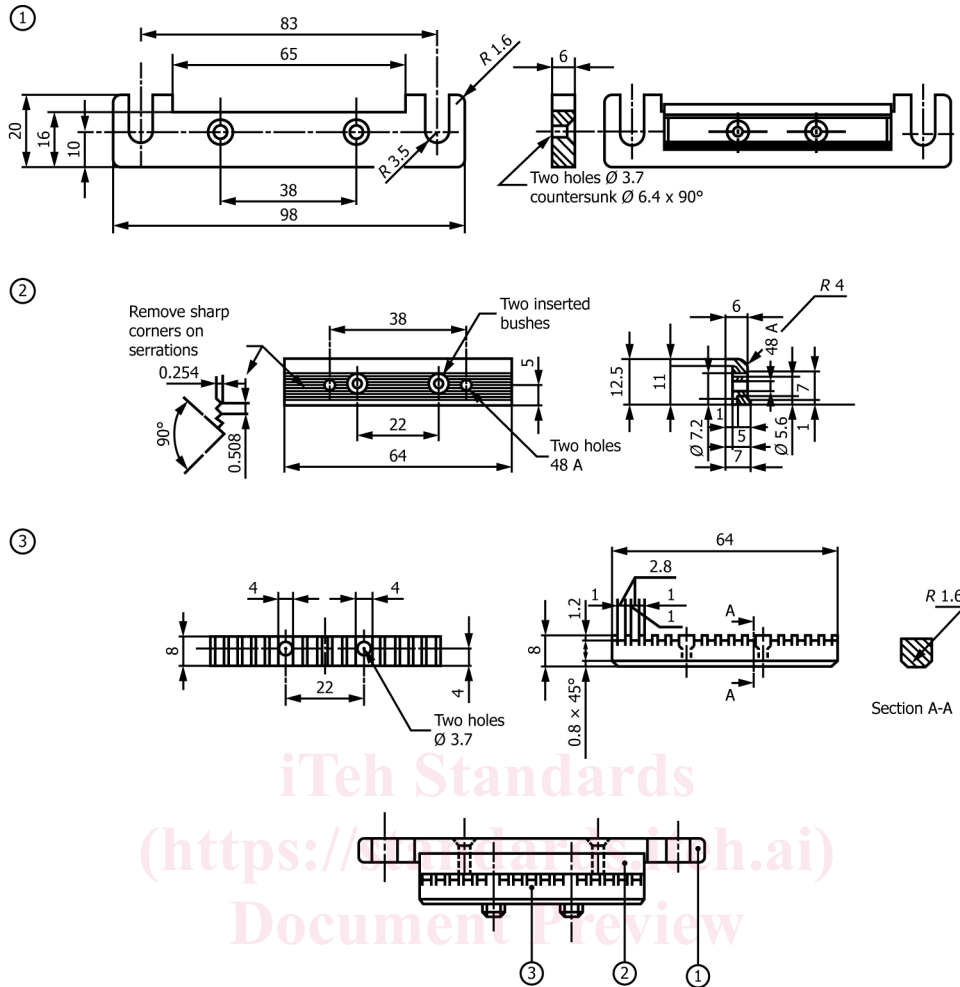

NOTE 1—Dimensions are in millimetres.

FIG. 5 Details of One Form of Clamp Meeting the Requirements of 6.1.2

<https://standards.iteh.ai/catalog/standards/sist/53a3114f-50d8-43f7-9b96-7baa1d67e926/astm-d746-14>

measurement. When this occurs, remove the ice from the temperature-measuring device.

Material	Temperature, °C
5-mm ² /s viscosity silicone oil	-60
2-mm ² /s viscosity silicone oil	-76
Methyl alcohol	-90

6.5 *Temperature Control*—Suitable means (automatic or manual) shall be provided for controlling the temperature of the heat-transfer medium to within $\pm 0.5^\circ\text{C}$ of the desired value. Powdered solid carbon dioxide (dry ice) and liquid nitrogen are recommended for lowering the temperature, and an electric immersion heater for raising the temperature.

6.6 *Tank*, insulated.

6.7 *Stirrer*, to provide thorough circulation of the heat transfer medium.

NOTE 5—Suitable apparatus is commercially available from several suppliers. The striking member may be motor-driven, solenoid-operated, gravity-actuated, or spring-loaded. Equip the motor-driven tester with a safety interlock to prevent striker arm motion when the cover is open.

7. Test Specimen

7.1 *Type I (for Type A Apparatus)*:

7.1.1 *Geometry*—This type of specimen shall be 6.35 ± 0.51 mm wide by 31.75 ± 6.35 mm long as illustrated in Fig. 6.

7.1.2 *Preparation*—Specimens shall be 1.91 ± 0.13 mm thick. Specimens shall be die-punched, cut by hand using a razor blade or other sharp tool, or cut by an automatic machine from flat sheet, or prepared by injection molding.

7.2 *Type II (for Type A Apparatus)*: