



Designation: ~~F2077~~ – ~~11~~ F2077 – 14

## Test Methods For Intervertebral Body Fusion Devices<sup>1</sup>

This standard is issued under the fixed designation F2077; the number immediately following the designation indicates the year of original adoption or, in the case of revision, the year of last revision. A number in parentheses indicates the year of last reapproval. A superscript epsilon ( $\epsilon$ ) indicates an editorial change since the last revision or reapproval.

### 1. Scope

1.1 This test method covers the materials and methods for the static and dynamic testing of intervertebral body fusion device assemblies, spinal implants designed to promote arthrodesis at a given spinal motion segment.

1.2 This test method is intended to provide a basis for the mechanical comparison among past, present, and future nonbiologic intervertebral body fusion device assemblies. This test method allows comparison of intervertebral body fusion device assemblies with different intended spinal locations and methods of application to the intradiscal spaces. This test method is intended to enable the user to compare intervertebral body fusion device assemblies mechanically and does not purport to provide performance standards for intervertebral body fusion device assemblies.

1.3 The test method describes static and dynamic tests by specifying force types and specific methods of applying these forces. These tests are designed to allow for the comparative evaluation of intervertebral body fusion device assemblies.

1.4 These tests are designed to characterize the structural integrity of the device and are not intended to test the bone-implant interface.

1.5 This test method does not address expulsion testing of intervertebral body fusion device assemblies (see 1.4).

1.6 Guidelines are established for measuring displacements, determining the yield force or moment, evaluating the stiffness, and strength of the intervertebral body fusion device assemblies.

1.7 Some intervertebral body fusion device assemblies may not be testable in all test configurations.

1.8 The values stated in SI units are to be regarded as standard. No other units of measurement are included in this standard, with the exception of angular measurements, which may be reported in terms of either degrees or radians.

1.9 *This standard does not purport to address all of the safety concerns, if any, associated with its use. It is the responsibility of the user of this standard to establish appropriate safety and health practices and determine the applicability of regulatory limitations prior to use.*

### 2. Referenced Documents

2.1 *ASTM Standards:*<sup>2</sup>

[E4 Practices for Force Verification of Testing Machines](#)

[E6 Terminology Relating to Methods of Mechanical Testing](#)

[E177 Practice for Use of the Terms Precision and Bias in ASTM Test Methods](#)

[E691 Practice for Conducting an Interlaboratory Study to Determine the Precision of a Test Method](#)

[E1823 Terminology Relating to Fatigue and Fracture Testing](#)

[E2309 Practices for Verification of Displacement Measuring Systems and Devices Used in Material Testing Machines](#)

[F1582 Terminology Relating to Spinal Implants](#)

### 3. Terminology

3.1 For definition of terms refer to Terminology [E6](#), [E1823](#), and [F1582](#).

3.2 *Definitions of Terms Specific to This Standard:*

<sup>1</sup> This test method is under the jurisdiction of ASTM Committee F04 on Medical and Surgical Materials and Devices and is the direct responsibility of Subcommittee F04.25.

Current edition approved July 15, 2011; Oct. 1, 2014. Published August 2011; December 2014. Originally published in 2000. Last previous edition approved in 2003; 2011 as F2077 – 03; F2077 – 11. DOI: 10.1520/F2077-11.10.1520/F2077-14.

<sup>2</sup> For referenced ASTM standards, visit the ASTM website, www.astm.org, or contact ASTM Customer Service at service@astm.org. For *Annual Book of ASTM Standards* volume information, refer to the standard's Document Summary page on the ASTM website.

3.2.1 *coordinate system/axes, n*—Three orthogonal axes are defined by Terminology F1582. The center of the coordinate system is located at the geometric center of the intervertebral body fusion device assembly. The XY plane is to bisect the sagittal plane angle between superior and inferior lines (surfaces) that are intended to simulate the adjacent vertebral end plates. The positive Z axis is to be directed superiorly. Force components parallel to the XY plane are shear components of loading. The compressive axial force is defined to be the component in the negative Z direction. Torsional force is defined to be the component of moment parallel to the Z axis.

3.2.2 *crack, n*—an externally visible physical discontinuity in the form of a narrow opening that arises from mechanical forces.

3.2.3 *fatigue life, n*—the number of cycles,  $N$ , that the intervertebral body fusion device assembly can sustain at a particular force or moment before mechanical or functional failure occurs.

3.2.4 *functional failure, n*—permanent deformation that renders the intervertebral body fusion device assembly ineffective or unable to resist force and/or maintain attachment adequately.

3.2.5 *ideal insertion location, n*—the implant location with respect to the simulated inferior and superior vertebral bodies (polyacetal or metal blocks) dictated by the type, design, and manufacturer’s surgical installation instructions.

3.2.6 *intended method of application, n*—intervertebral body fusion device assemblies may contain different types of stabilizing anchors such as threads, spikes, and knurled surfaces. Each type of anchor has an intended method of application or attachment to the spine.

3.2.7 *intended spinal location, n*—the anatomic region of the spine intended for the intervertebral body fusion device assembly. Intervertebral body fusion device assemblies may be designed and developed for specific regions of the spine such as the lumbar, thoracic, and cervical spine. Also, there exists different anatomical potential surgical approaches, which will result in different implant orientation at different levels of the spine.

3.2.8 *intervertebral body fusion device, n*—a structure (biologic or synthetic) that is placed in the disc space between two adjacent vertebral bodies to provide support for eventual arthrodesis of the two adjacent vertebral bodies.

3.2.9 *intradiscal height, n*—the straight-line distance along the Z axis between the unaltered simulated vertebral bodies—minimum height of 4 mm and a maximum height of 18 mm. See Fig. 1.

3.2.10 *force point, n*—the point through which the resultant force on the intervertebral device passes (that is, the geometric center of the superior fixture’s sphere) (Figs. 2-5).

3.2.11 *maximum run out force or moment, n*—the maximum force or moment for a given test that can be applied to an intervertebral body fusion device assembly in which all of the tested constructs have withstood 5 000 000 cycles without functional or mechanical failure.

3.2.12 *mechanical failure, n*—that associated with the onset of a new defect in the material (that is, initiation of fatigue crack).

3.2.13 *offset angular displacement, n*—(Distance OB—Fig. 6)—offset on the angular displacement axis equal to 10 % of the intradiscal height,  $H$ , divided by the outside diameter or height of the implant (maximum dimension of implant in XZ plane if not cylindrical) (for example, for a 10-mm intradiscal height and 16-mm intervertebral body fusion device assembly, distance  $OB = 10 \text{ mm}/16 \text{ mm} (0.10)(180^\circ)/\pi = 3.6^\circ$ ).

3.2.14 *offset displacement, n*—(Distance OB—Fig. 6)—offset on the displacement axis equal to 2 % of the intradiscal height (that is, 0.2 mm for a 10-mm intradiscal height).

3.2.15 *permanent deformation, n*—the remaining displacement (mm or degrees or radians) relative to the initial unloaded condition of the intervertebral body fusion device assembly after the applied force has been removed.

3.2.16 *stiffness (N/mm or N\*mm/Degree (Radian)) (The Slope of Line OG—Fig. 6), n*—the slope of the initial linear portion of the force-displacement curve or the slope of the initial linear portion of the moment—angular displacement curve.

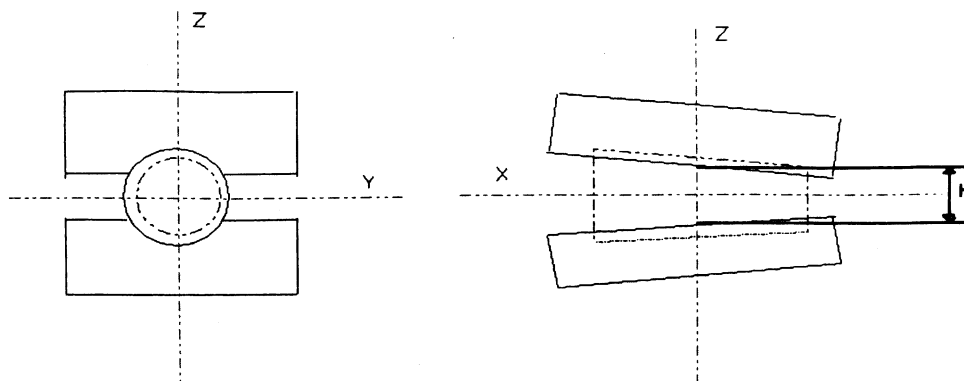

FIG. 1 Intradiscal Height Diagram

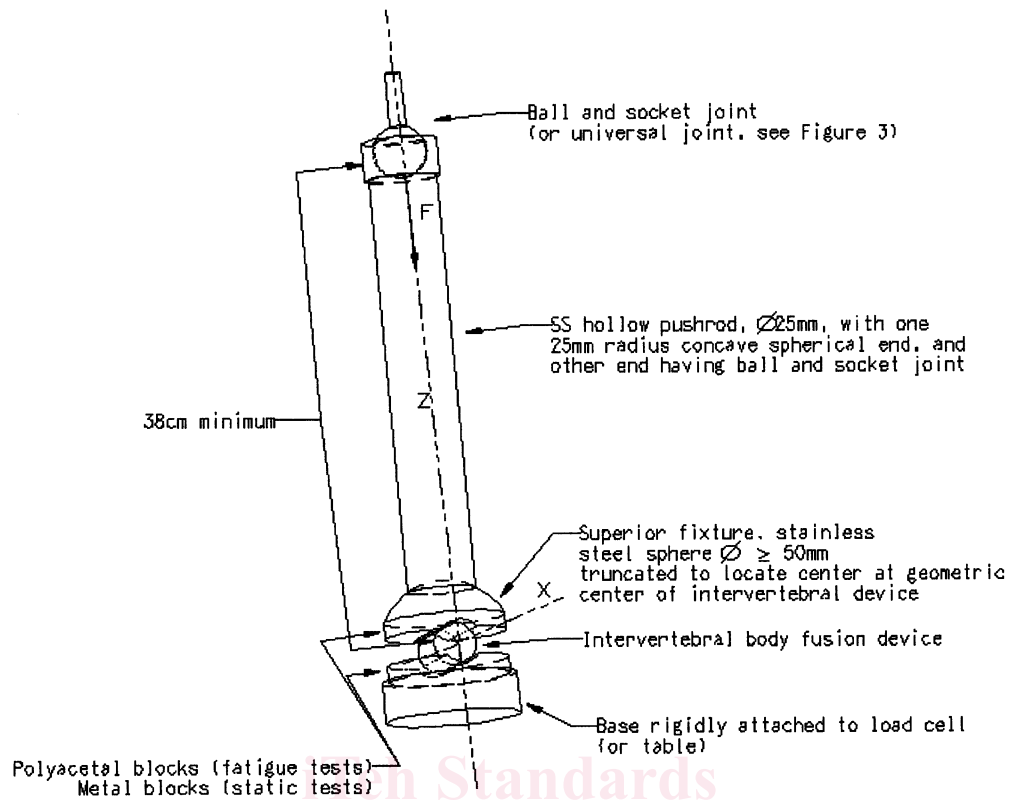

FIG. 2 Compression Testing Configuration

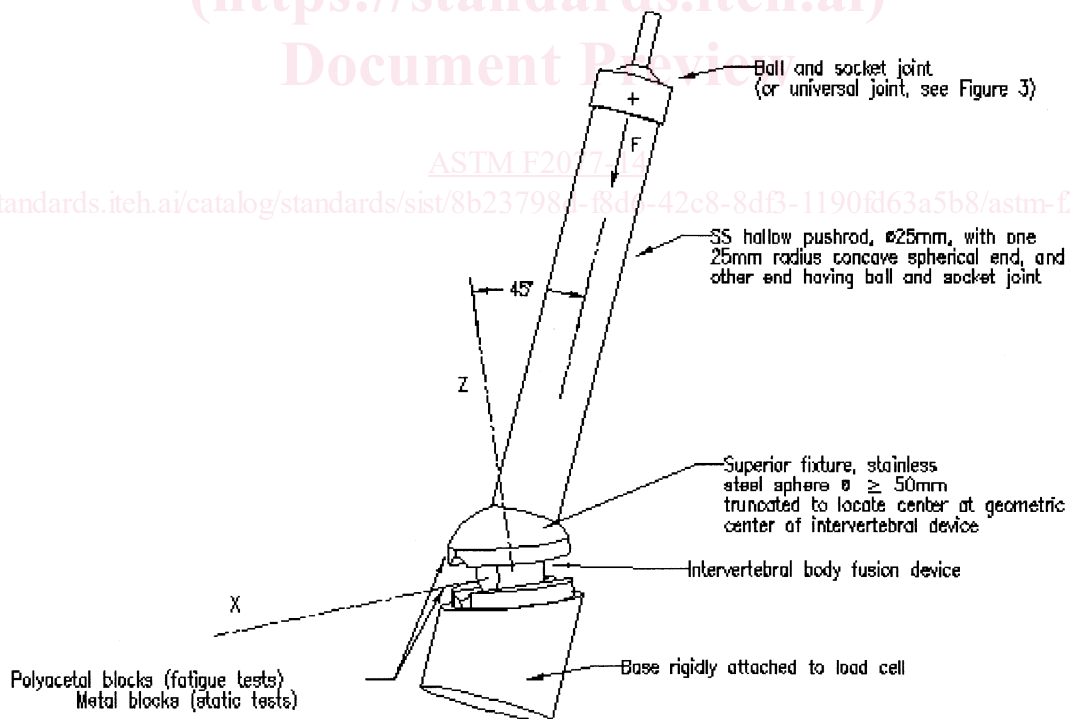

FIG. 3 Compression-Shear Testing Configuration

3.2.17 *test block, n*—the component of the test apparatus for mounting the intervertebral body fusion device assembly for the intended test configuration.

3.2.18 *ultimate displacement (mm or degrees or radians) (Displacement OF—Fig. 6), n*—the displacement associated with the ultimate force or ultimate moment.

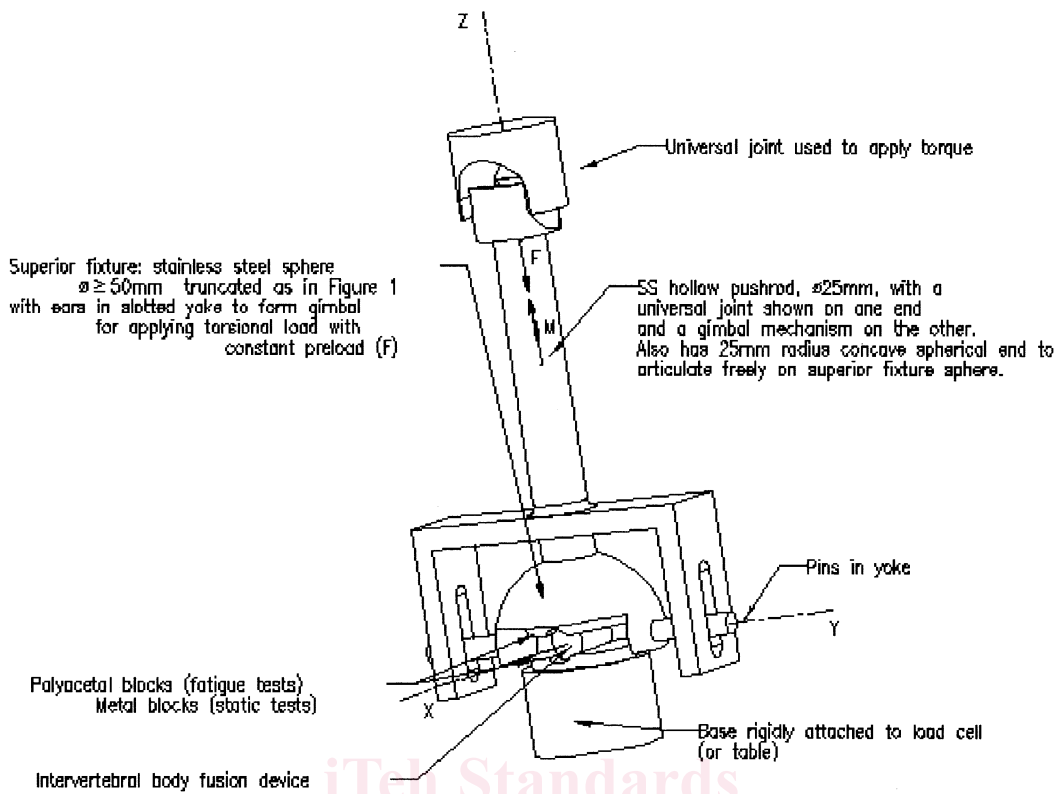

FIG. 4 Torsion Testing Configuration With Pin-Slot Gimbal

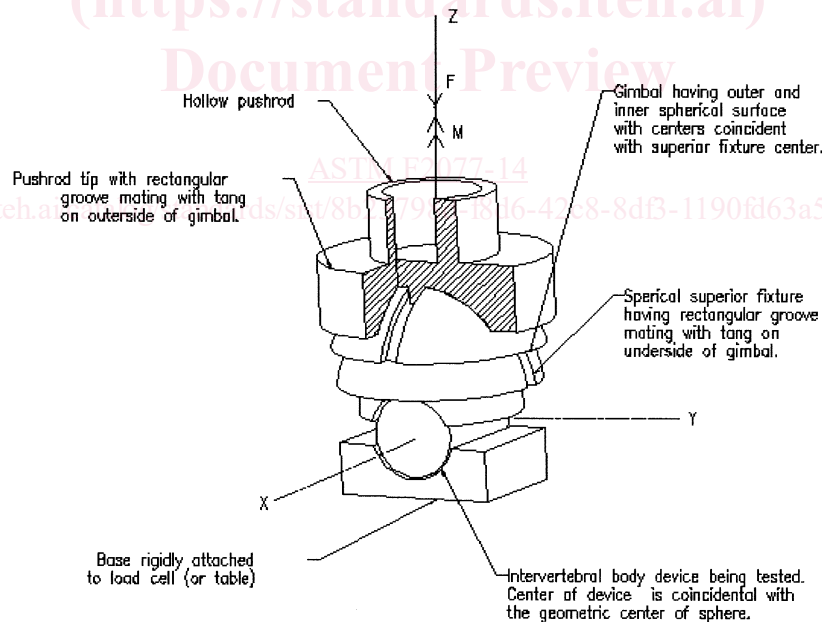

FIG. 5 Spherical Gimbal (Cross Section) for Torsion Testing Apparatus

3.2.19 *ultimate force or moment* ( $N$  or  $N^*mm$ ) (Point E—Fig. 6),  $n$ —the maximum applied force,  $F$ , transmitted by the pushrod (assumed equal to force component parallel to and indicated by load cell), or the applied moment about the  $Z$  axis that can be applied to an intervertebral body fusion device assembly.

3.2.20 *yield displacement* (Distance  $OA$ —Fig. 6),  $n$ —the displacement (mm) or angular displacement (deg) when an interbody fusion device assembly has a permanent deformation equal to the offset displacement or the offset angular displacement.

3.2.21 *yield force or moment* (Point D—Fig. 6),  $n$ —the applied force,  $F$ , transmitted by the pushrod (assumed equal to force component parallel to and indicated by load cell), or the applied moment about the  $Z$  axis required to produce a permanent deformation equal to the offset displacement or the offset angular displacement.

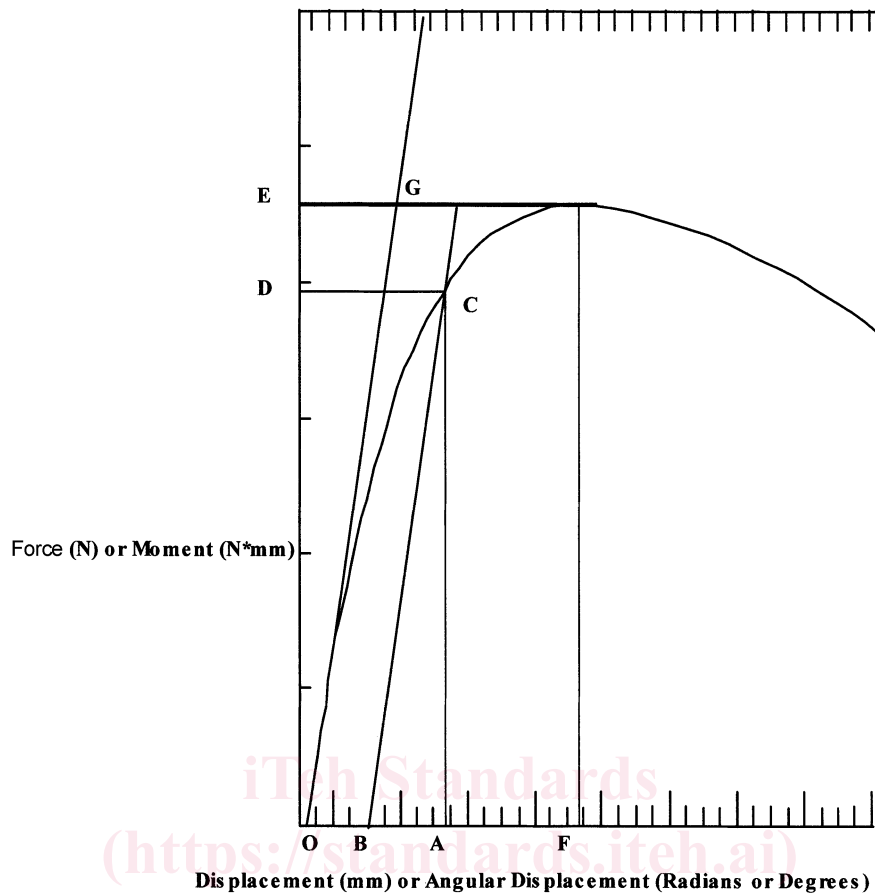

FIG. 6 Typical Force Displacement Curve

ASTM F2077-14

4. Summary of Test Method

4.1 These test methods are proposed for the mechanical testing of intervertebral body fusion device assemblies specific to the lumbar, thoracic, and cervical spine.

4.2 Fatigue testing of the intervertebral body fusion device assemblies will simulate a motion segment via a gap between two polyacetal test blocks. The polyacetal will eliminate the effects of the variability of bone properties and morphology for the fatigue tests. The minimum ultimate tensile strength of the polyacetal blocks shall be no less than 61 MPa.

4.3 Static testing of the intervertebral body fusion device assemblies will simulate a motion segment via a gap between two stainless steel blocks. The minimum ultimate tensile strength of the blocks shall be no less than 1310 MPa.

4.4 The pushrod shall also be manufactured from stainless steel, which shall also have a minimum ultimate tensile strength no less than 1310 MPa.

4.5 Static and dynamic tests will evaluate the intervertebral body fusion device assembly. The user of this test method must decide which series of tests are applicable to the intervertebral body fusion device assembly in question. The user of this test method may choose to use all or a selection of the tests described in this test method for testing a particular intervertebral body fusion device assembly.

5. Significance and Use

5.1 Intervertebral body fusion device assemblies are generally simple geometric-shaped devices which are often porous or hollow in nature. Their function is to support the anterior column of the spine to facilitate arthrodesis of the motion segment. This test method outlines materials and methods for the characterization and evaluation of the mechanical performance of different intervertebral body fusion device assemblies so that comparisons can be made between different designs.

5.2 This test method is designed to quantify the static and dynamic characteristics of different designs of intervertebral body fusion device assemblies. These tests are conducted *in vitro* to allow for analysis and comparison of the mechanical performance of intervertebral body fusion device assemblies to specific force modalities.

5.3 The forces applied to the intervertebral body fusion assemblies may differ from the complex loading seen *in vivo*, and therefore, the results from these tests may not directly predict *in vivo* performance. The results, however, can be used to compare mechanical performance of different intervertebral body fusion device assemblies.

5.4 Since the environment may affect the dynamic performance of intervertebral body fusion device assemblies, dynamic testing in a saline environment may be considered. Fatigue tests should first be conducted in air (at ambient temperature) for comparison purposes since the environmental effects could be significant. If a simulated *in vivo* environment is desired, the investigator should consider testing in a saline environmental bath at 37°C (for example, 0.9-g NaCl per 100-mL water) at a rate of 1 Hz or less. A simulated body fluid, a saline drip or mist, distilled water, or other type of lubrication at 37°C could also be used with adequate justification.

5.5 If the devices are known to be temperature and environment dependent, testing should be conducted in physiologic solution as described in 5.4. Devices that require physiologic solution for testing should be tested in the same type solution for comparison purposes.

5.6 The location within the simulated vertebral bodies and position of the intervertebral body fusion device assembly with respect to the loading axis will be dependent upon the design, the manufacturer’s recommendation, or the surgeon’s preferred method for implant placement.

5.7 It is well known that the failure of materials is dependent upon stress, test frequency, surface treatments, and environmental factors. Therefore, when determining the effect of changing one of these parameters (for example, frequency, material, or environment), all others must be kept constant to facilitate interpretation of the results.

## 6. Apparatus

6.1 Test machines will conform to the requirements of Practices E4.

6.2 The intradiscal height,  $H$ , shall be determined from vertebral body and disc morphometric data at the intended level of application. Suggested heights are as follows: 10 mm for the lumbar spine, 6 mm for the thoracic spine, and 4 mm for the cervical spine. The intradiscal height should not reach zero before the onset of functional or mechanical failure. If this occurs, the test is considered a failure. The user of the test method should select the intradiscal height that is appropriate for the device being tested.

6.3 *Axial Compression Test Apparatus*—The actuator of the testing machine is connected to the pushrod by a minimal friction ball and socket joint or universal joint (that is, unconstrained in bending). The pushrod is connected to the superior fixture by a minimal friction sphere joint (that is, unconstrained in bending and torsion). The hollow pushrod should be of minimal weight so as to be considered a “two-force” member. It thus applies to the intervertebral body fusion device assembly a resultant force directed along the pushrod’s axis and located at the center of the superior fixture’s sphere joint (the geometric center of the device being tested). For the fatigue tests, the device is placed between two polyacetal blocks, which are rigidly attached to the metal blocks (Fig. 2). For the static tests, metal blocks are to be used, which could be incorporated as an integral part of the superior and inferior fixtures. The blocks are to have surfaces that mate geometrically with the intervertebral device similar to how the device is intended to mate with vertebral end plates. The test apparatus will be assembled such that the  $Z$  axis of the intervertebral device is initially coincident with the pushrod’s axis and collinear with the axis of the testing machine’s actuator and load cell. The length of the pushrod between the center of the ball-and-socket joint to the center of the spherical surface is to be a minimum of 38 cm. This is required to minimize deviation of the pushrod’s axis (direction of applied force,  $F$ ) from that of the test machine’s load cell axis. In other words, this is to minimize the error in using and reporting that the force indicated by the load cell “ $F_{ind}$ ” is the applied force,  $F$ , and is equal to the compressive force,  $F_z$ , on the intervertebral body fusion device assembly. For example, a 1-mm displacement of the spherical surfaces center in the  $XY$  plane would produce an angle between axes of 0.15°, (10 mm producing 1.5°). Fig. 2 is a schematic of this test set-up.

6.4 *Compression-Shear Testing Apparatus*—The compression-shear test apparatus (Fig. 3), with exception of the inferior fixture, is identical to the axial compression apparatus (Fig. 2). The inferior fixture is to be designed to orient the initial position of the intervertebral device’s  $Z$  axis at either 45° or 27°<sup>3</sup> flexion relative to the pushrod’s axis. The resultant force,  $F$ , being applied to the intervertebral body fusion device assembly passes through the center of the superior fixture’s spherical surface and is coincident with the pushrod’s axis. Thus, a combined compressive force  $F_z$  and an anterior shear force  $F_x$  is created, which initially are either equal in magnitude or  $F_z$  is twice that of  $F_x$  and passes through the geometric center of the intervertebral body fusion device assembly.

NOTE 1—Benfanti<sup>3</sup> and colleagues measured the L5-S1 angle in 14 healthy volunteers in a standing position and obtained an average of  $16.1 \pm 3.3^\circ$ . Assuming a normal distribution, an angle of greater than the average  $+3\sigma$  would represent greater than 99.7 % of the population.  $16.1 \pm 9.9^\circ = 26^\circ$ ; however, using an angle of 26.6°, rounded to 27°, is convenient as the normal force is twice that of the shear force.

6.5 *Torsion Testing Apparatus*—The torsion test apparatus (Fig. 4) is similar to the axial compression test apparatus (Fig. 2) with exception of the pushrod interconnections. The actuator of the testing machine must be connected to the pushrod by a minimal

<sup>3</sup> Benfanti P. L., Geissele, A. E., “The effect of intraoperative hip position on maintenance of lumbar lordosis: a radiographic study of anesthetized patients and unanesthetized volunteers on the Wilson frame,” *Spine*, Vol 22, No. 19, 1997, pp. 2299–2303.