



Standard Specification for Thrusters, Tunnel, Permanently Installed in Marine Vessels¹

This standard is issued under the fixed designation F 841; the number immediately following the designation indicates the year of original adoption or, in the case of revision, the year of last revision. A number in parentheses indicates the year of last approval. A superscript epsilon (ϵ) indicates an editorial change since the last revision or reapproval.

This standard has been approved for use by agencies of the Department of Defense.

1. Scope

1.1 This specification supplies general characteristics and interface details of propeller type, fixed-tunnel thruster units permanently installed in marine vessels or structures.

1.2 Values stated in either inch-pound units or SI (metric) units are to be regarded separately as standard. The values stated in each system must be used independent of the other. Combining values from the two systems may result in nonconformance with the specification.

NOTE 1—This specification supplies only general design, interface, and purchase information and does not include requirements for use, thruster controls, or associated equipment. The purchaser of the thruster equipment specified herein is cautioned that he must properly correlate the operating requirements with the thruster specified.

1.3 *This standard does not purport to address all of the safety concerns, if any, associated with its use. It is the responsibility of the user of this standard to establish appropriate safety and health practices and determine the applicability of regulatory limitations prior to use.*

2. Referenced Documents

2.1 ASTM Standards:

A 296 Specification for Corrosion-Resistant Iron-Chromium and Iron-Chromium Nickel and Nickel-B Alloy Casting²

F 25 Test Method for Sizing and Counting Airborne Particulate Contamination in Clean Rooms and Other Dust-Controlled Areas Designed for Electronic and Similar Applications³

2.2 American Bureau of Shipping:⁴

ABS Rules for Building and Classing Steel Vessels

2.3 ISO Document:⁵

ISO Recommendation ISO/DIS 484/11 (Draft)

3. Definitions of Terms Specific to This Standard

3.1 *thruster*—a device constructed such as to provide a force or thrust of controlled variable magnitude and direction to a marine vessel or structure, usually, but not limited to, a propeller mounted within a tunnel located below water level.

3.2 *fixed pitch*—(FP) a propeller in which the blades are part of, or are rigidly attached to, the hub such that the propeller pitch is constant for a given radius.

3.3 *controllable pitch*—(CP) a propeller in which the blades are attached to a mechanism within the hub by means of bolts or fasteners, so that controlled movement of the mechanism causes the blades to change pitch in unison.

3.4 *tunnel*—a part of thruster assembly of circular cross section which houses structure supporting a propeller and drive mechanism.

3.5 *peak power*—highest horsepower developed by the prime mover, or as limited by the thruster manufacturer.

3.6 *continuous duty*—operation of the thruster continuously at any power range, up to manufacturer's rating, for extended periods, but not to overlap into recommended maintenance intervals.

3.7 *intermittent duty*—operation of the thruster at peak power or RPM levels, or both, for periods not exceeding 1 h followed by periods of 1 h at the continuous rating or less, with total running time not exceeding 8 h in 24 h.

3.8 *landing bars*—permanent attachments, usually in the form of plates welded to the tunnel during manufacture, intended to provide joining facilities for deck plates or bulkheads, or both, at installation. Landing bars are neither intended to be part of the support structure for the thruster, nor provide support or transmit forces from the vessel structure to the thruster.

3.9 *prime mover*—the motor(s) or engine(s) providing the power to drive the thruster.

3.10 *grid bars*—bars installed at the tunnel entrances in the form of a mesh to prevent large objects from passing through the thruster tunnel. The area occupied by the grid bars shall not exceed 6 % of the tunnel cross-sectional area.

¹ This specification is under the jurisdiction of ASTM Committee F-25 on Ships and Marine Technology and is the direct responsibility of Subcommittee F25.11 on Machinery.

Current edition approved April 12, 1984. Published June 1984.

² Discontinued—See *Annual Book of ASTM Standards*, Vol 01.02.

³ *Annual Book of ASTM Standards*, Vol 10.05.

⁴ Available from American Bureau of Shipping, 65 Broadway, New York, NY 10006.

⁵ Available from American National Standards Institute, 11 W. 42nd St., 13th Floor, New York, NY 10036.

4. Classification

- 4.1 Thrusters manufactured in accordance with this specification shall be identified as follows:
 - 4.1.1 *Type I*—Fixed pitch.
 - 4.1.2 *Type II*—Controllable pitch.
- 4.2 Each type of thruster may be manufactured to the following grade:
 - 4.2.1 *Grade 1*—Intermittent duty for docking and navigation.
 - 4.2.2 *Grade 2*—Continuous duty for stationkeeping or dynamic positioning.

5. Ordering Information

- 5.1 Requests for quotation and purchase orders shall specify the following (in absence of specific requirements in ordering data, the unit will be provided only as specified herein):
 - 5.1.1 Description of thruster.
 - 5.1.2 ASTM designation and date of issue.
 - 5.1.3 Type.
 - 5.1.4 Grade.
 - 5.1.5 Input Shaft Angle—Refer to Fig. 1.
 - 5.1.6 Tunnel Extensions—Refer to Fig. 2.

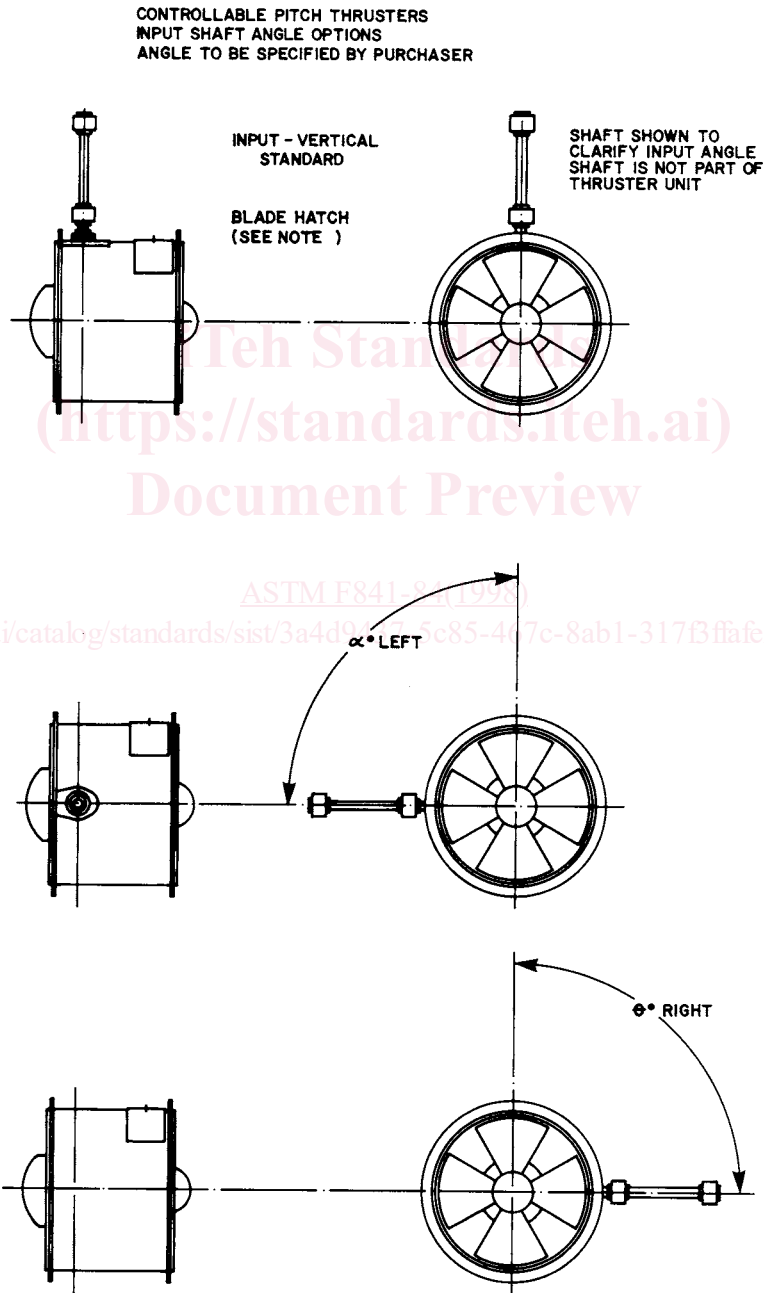

NOTE 1—The thruster will be supplied without the blade hatch unless otherwise specified in the ordering data.

FIG. 1 Input Shaft Angle