



Designation: **E2786–10** E2786 – 10 (Reapproved 2015)

Standard Test Methods for Measuring Expansion of Intumescent Materials Used in Firestop and Joint Systems¹

This standard is issued under the fixed designation E2786; the number immediately following the designation indicates the year of original adoption or, in the case of revision, the year of last revision. A number in parentheses indicates the year of last reapproval. A superscript epsilon (ϵ) indicates an editorial change since the last revision or reapproval.

1. Scope

1.1 These test methods determine, by measurement, the expansion of intumescent materials used in firestop and joint systems under specified conditions.

1.2 The values stated in inch-pound units are to be regarded as standard. The values given in parentheses are mathematical conversions to SI units that are provided for information only and are not considered standard.

1.3 The text of these test methods references notes and footnotes which provide explanatory material. These notes and footnotes (excluding those in tables and figures) shall not be considered as requirements of the fire test response standard.

1.4 *This standard does not purport to address all of the safety concerns, if any, associated with its use. It is the responsibility of the user of this standard to establish appropriate safety and health practices and determine the applicability of regulatory limitations prior to use.*

2. Referenced Documents

2.1 *ASTM Standards:*²

E176 Terminology of Fire Standards

E631 Terminology of Building Constructions

3. Terminology

3.1 *Definitions*—Definitions in the following standards will prevail for terms not defined in these test methods.

3.1.1 For definitions of general terms used in these test methods related to building construction, refer to Terminology **E631**.

3.1.2 For definitions of general terms used in these test methods related to fire standards, refer to Terminology **E176**.

3.2 *Definitions of Terms Specific to This Standard:*

3.3 *expansion, n*—an increase in the dimensions as the result of heating.

3.4 *intumescent, adj*—characterized by swelling when exposed to high surface temperatures or flames.

3.4 *expansion factor, n*—the ratio of the material height before and after heating, under test conditions that allow expansion only in the vertical direction.

3.5 *intumescent, adj*—characterized by swelling when exposed to high surface temperatures or flames.

4. Summary of Test Method

4.1 These test methods place a material of a specified thickness or volume into a specific device that is capable of heating the material.

4.2 After the material is heated, its dimensional or volumetric change is measured.

4.3 Two test methods are provided, one using a test specimen holder (Test Method A) and the other using a water displacement method (Test Method B).

¹ These test methods are under the jurisdiction of ASTM Committee **E06** on Performance of Buildings and is the direct responsibility of Subcommittee **E06.21** on Serviceability.

Current edition approved Oct. 1, 2010/Jan. 1, 2015. Published November 2010/January 2015. Originally approved in 2010. Last previous edition approved in 2010 as **E2786–10**. DOI: [10.1520/E2786-10](https://doi.org/10.1520/E2786-10); [10.1520/E2786-10R15](https://doi.org/10.1520/E2786-10R15).

² For referenced ASTM standards, visit the ASTM website, www.astm.org, or contact ASTM Customer Service at service@astm.org. For *Annual Book of ASTM Standards* volume information, refer to the standard's Document Summary page on the ASTM website.

4.4 Test Method A may be used for measuring expansion of any material.

4.5 Test Method B may be used for measuring expansion of any material, except for those materials that are granular, that are susceptible to absorbing paraffin in conditioned pre-expanded state or post-expanded state, or that are susceptible to damage or deformation in a post-expanded state.

4.6 The test method used must be reported, as use of different test methods will result in different expansion factors.

5. Significance and Use

5.1 These test methods are intended to measure the material’s expansion after heating.

5.2 The test methods also provide a means to determine the expansion factor.

6. Apparatus

6.1 *Heating Device*—An enclosed furnace or oven or similar equipment capable of maintaining the temperature specified herein and large enough to contain the test specimen holder.

6.2 *Test Method A—Test Specimen Holder Method:*

6.2.1 *Test Specimen Holder*—A Series 300 stainless steel assembly consisting of at least two cylinders contained in a frame into which the material is placed. Each cylinder shall be nominally 5 in. (130 mm) high with a nominal 2 in. (50 mm) outside diameter. Fig. 1 is an example of a test specimen holder. Wall thickness shall be nominal 0.08 in. (2 mm).

6.2.2 *Restrictor Plate*—A Series 300 stainless steel disc with a diameter of 0.01 to 0.015 in. (0.25 to 0.38 mm) less than that of the cylinder in 6.2.1 and with a mass of 1.14 oz/in² (5 g/cm²), ±0.023 oz/in² (0.1 g/cm²).

NOTE 1—For a Series 300 stainless steel, a qualifying restrictor plate can be made from solid bar stock with an O.D. of 1.82 in. (46.2 mm) and a thickness of 0.25 in. (6.5 mm) (see Fig. 2).

6.2.3 *Steel rule die* with the same width as the diameter of the cylinder in 6.2.1, +0.0 – 0.015 in. (+0 – 0.38 mm).

6.2.4 The following are needed to prepare some test specimens:

6.2.4.1 A dial caliper with a smallest division of 0.001 in. (0.025 mm),

6.2.4.2 Drying oven capable of reaching and maintaining 212°F (100°C),

6.2.4.3 A balance accurate to ±0.00035 oz (±0.01 g),

6.2.4.4 A small hydraulic press with platens larger than 5 in. (130 mm) square,

6.2.4.5 Two nominal 0.25 in. (6.4 mm) thick metal shims at least 4 in. (100 mm) long to create the needed product thickness in the press,

6.2.4.6 Release liner paper, and

6.2.4.7 Steel ruler graduated to 0.0156 in. (0.39 mm).

6.3 *Test Method B—Water Displacement Method (See Fig. 3):*

6.3.1 *Base*, independent of the balance,

6.3.2 *Steel rule die*, 1 in. (25 mm) diameter,

6.3.3 *Glass beaker*, 400-mL smooth wall type,

6.3.4 *Weight* with hook attached,

6.3.5 *Aluminum tins*,

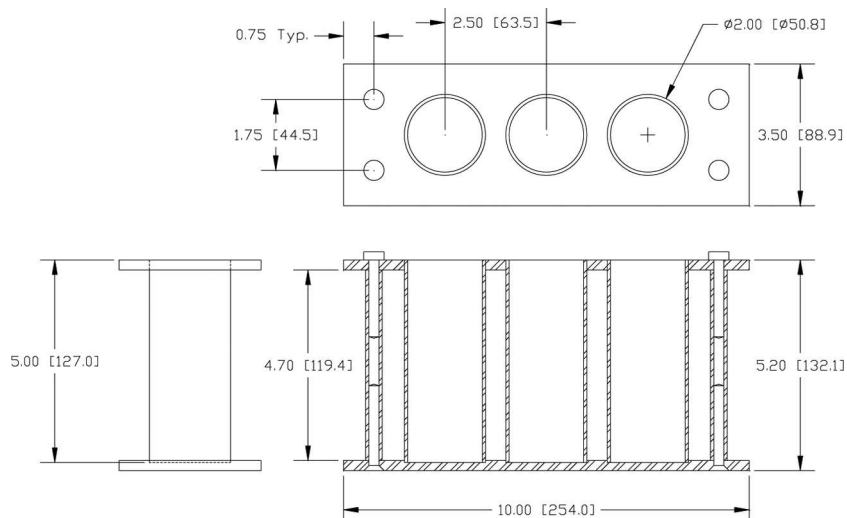

FIG. 1 Test Specimen Holder (Test Method A)

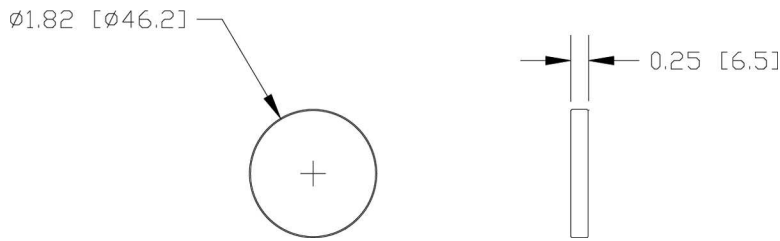

FIG. 2 Restrictor Plate

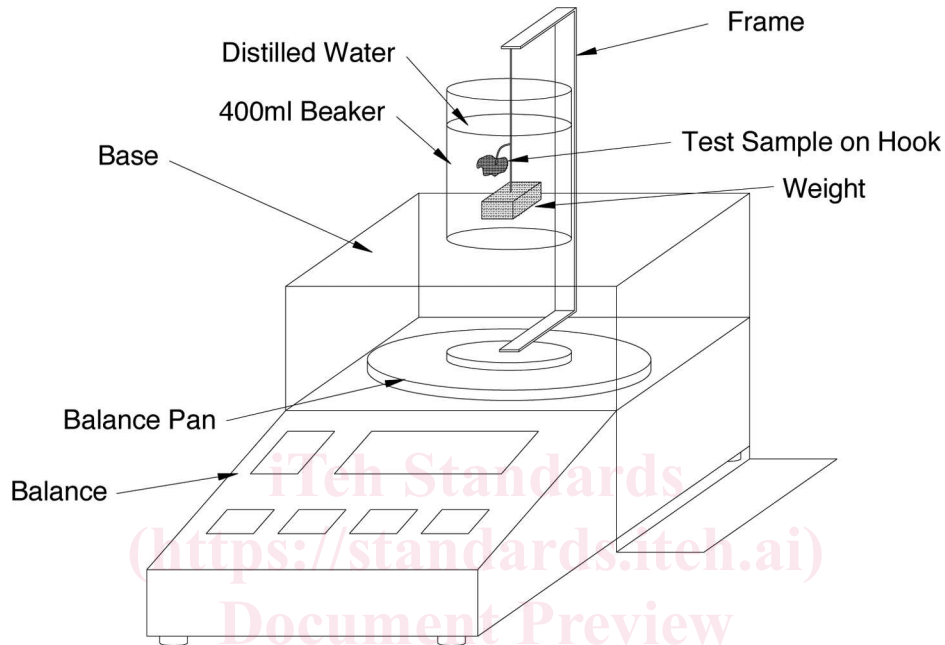

FIG. 3 Test Method B Apparatus

6.3.6 Electric hot plate for heating wax,

6.3.7 Paraffin wax with Melting Point of 132.8°F – 134.6°F (56°C – 57°C), or equivalent.

6.3.8 Distilled Water.

7. Hazards

7.1 This test method uses equipment, which alters a material's state that may create noxious gases that may be harmful. Care should be taken to provide adequate ventilation for all equipment capable of producing this effect.

8. Sampling, Test Specimens, and Test Units

8.1 Samples representative of the material shall be randomly selected. Record the name, address, manufacturer's designation, and lot number for the material that was used for the test sample.

NOTE 2—When samples are selected by the laboratory or its authorized representative as part of a quality assurance program, the samples shall be duly marked to ensure traceability.

NOTE 3—Samples may be selected from other sources other than the manufacturer's facility. The manufacturer of the samples may not be known.

8.2 The results of this test are only applicable to the specific nominal thickness and density of the material sampled and tested.

8.3 At least three test specimens shall be used.

8.4 Each test specimen shall be a single piece without any joints.

8.4.1 *Exception 1*—Granular materials.

8.4.2 *Exception 2*—Materials that have dimensions that are smaller than required to create a 2 in. (50 mm) method A or 1 in. (25 mm) method B, diameter round test sample shall be joined together to create the test specimen. The method of joining shall be acceptable to the test sponsor and to the testing laboratory.

NOTE 4—When joining is required, the method of joining should not have any significant anticipated effect on the results of the test. Prepare all test specimens using the same method for each material.

NOTE 5—When comparing results between laboratories or tests, it is critical that the same preparation and test method is used in all tests.

8.5 For preformed materials, cut the samples into disc-shaped test specimens using a die.

8.6 For caulk and putty materials:

8.6.1 Cut two pieces of release liner paper into nominal 5 in. (125 mm) squares for each test specimen. Place enough material in the center of one sheet so that when compressed it will create a nominal 4 in. (100 mm) square by 0.25 in. (6.4 mm) thick sample. Place the other sheet of release liner paper squarely over the top of the first, sandwiching the material between them.

8.6.2 Place the metal shims along the outer edges of the platen press.

8.6.3 Place the release liner paper and material sandwich between and in the center of the platen press.

8.6.4 Close the press so that it stops at the metal shims. Leave the release liner paper and material sandwich in the press for at least 30 s.

8.6.5 Remove sample from press.

8.6.6 Cure samples in accordance with manufacturer's published instructions.

8.6.7 Take the release liner with material out of the oven and let it cool to room temperature, then remove the top and bottom layers of the release liner paper and remove the cured material.

8.6.8 Cut the sample into at least three disc-shaped test specimens using a die.

8.7 For granular materials:

8.7.1 Pour granules into a 100 ml graduated cylinder.

8.7.2 Tap the graduated cylinder on hard surface 10 times.

8.7.3 Read and record the volume of granules in the graduated cylinder to the nearest millilitre (see 12.1.2.1).

8.7.4 Pour material into test specimen holder.

8.7.5 Repeat steps 8.7.1 – 8.7.4 until three test samples are prepared for heating.

8.8 Each test specimen shall have its own identification or designation. All information recorded shall reference that identification or designation.

9. Preparation of Apparatus

9.1 *Test Temperatures*—Prior to conducting the test, the heating device shall be brought to equilibrium at the required test temperature.

9.2 The test specimen holder, used for Test Method A, shall be cleaned prior to performing each test. Cleaning shall incorporate any process used at the discretion of the laboratory that will render the apparatus free from any debris or residue from previous testing. The apparatus shall also be fully dry prior to installing test specimens.

10. Calibration and Standardization

10.1 The temperature in the heating device shall be verified using a thermocouple or thermometer that is accurate to $\pm 5^\circ\text{F}$ ($\pm 3^\circ\text{C}$).

10.2 The measuring device used to determine expansion shall be accurate to ± 0.01 in. (± 0.25 mm).

10.3 The measuring device used to determine the initial thickness of the samples shall be accurate to ± 0.001 in. (± 0.025 mm).

11. Conditioning

11.1 All test specimens shall be conditioned to equilibrium by weight in a room or chamber with a temperature of $72^\circ\text{F} \pm 5^\circ\text{F}$ ($23 \pm 3^\circ\text{C}$) at 50 ± 5 % RH. Weigh and record the weight of each test specimen once a day until equilibrium is reached. Equilibrium is considered achieved when the weight change is less than 1 % per day. After the samples have reached equilibrium, they are to be retrieved and tested within 1 hour after removal from the conditioning environment.

12. Procedure

TEST METHOD A – TEST SPECIMEN HOLDER METHOD

12.1 Measure the pre-test sample dimensions:

12.1.1 *Solid Samples:*

12.1.1.1 Measure and record each preformed test specimen thickness at five symmetrical points as shown in Fig. 4 for three test specimens. For granular materials, see 12.1.2.

12.1.1.2 Measure the thickness as shown in Fig. 4 within ± 0.001 in. (± 0.025 mm). Record this measurement as H_s (see 13.1.1).

12.1.2 *Granular Samples:*

12.1.2.1 Use the volume recorded in 8.7.3. Divide the volume by the cross-sectional area of the inside of the test specimen holder cylinder. Record this value as H_s .

NOTE 6—For the cylinder dimension discussed in 6.2.1, the inside diameter of commercially available stainless steel tubing is 1.834 in. (46.6 mm) and the correlating area is 2.64 in² (17 cm²).

12.2 Place test specimens into the test specimen holder. Place one sample in the bottom of each cylinder. Each test specimen shall be laid flat in the bottom of the cylinder. Cover the test specimen with the Restrictor Plate as described in 6.2.2.