



Designation: F 847 – 94 (Reapproved 1999)

## Standard Test Methods for Measuring Crystallographic Orientation of Flats on Single Crystal Silicon Wafers by X-Ray Techniques<sup>1</sup>

This standard is issued under the fixed designation F 847; the number immediately following the designation indicates the year of original adoption or, in the case of revision, the year of last revision. A number in parentheses indicates the year of last reapproval. A superscript epsilon ( $\epsilon$ ) indicates an editorial change since the last revision or reapproval.

### 1. Scope

1.1 These test methods cover the determination of  $\alpha$ , the angular deviation between the crystallographic orientation of the direction perpendicular to the plane of a fiducial flat on a circular silicon wafer, and the specified orientation of the flat in the plane of the wafer surface.

1.2 These test methods are applicable for wafers with flat length values in the range of those specified for silicon wafers in SEMI Specification M 1. They are suitable for use only on wafers with angular deviations of less than  $\pm 5^\circ$ .

1.3 The orientation accuracy achieved by these test methods depends directly on the accuracy with which the flat surface can be aligned with a reference fence and the accuracy of the orientation of the reference fence with respect to the X-ray beam.

1.4 Two test methods are covered as follows:

	Sections
Test Method A—X-Ray Edge Diffraction Method	8 to 13
Test Method B—Laue Back Reflection X-Ray Method	14 to 18

1.4.1 Test Method A is nondestructive and is similar to Test Method A of Test Methods F 26 except that it uses special wafer holding fixtures to orient the wafer uniquely with respect to the X-ray goniometer. The technique is capable of measuring the crystallographic direction of flats to a greater precision than the Laue back reflection method.

1.4.2 Test Method B is also nondestructive, and is similar to Test Method E 82, and to DIN 50 433, Part 3, except that it uses “instant” film and special fixturing to orient the flat with respect to the X-ray beam. Although it is simpler and more rapid, it does not have the precision of Test Method A because it uses less precise and less expensive fixturing and equipment. It produces a permanent film record of the test.

NOTE 1—The Laue photograph may be interpreted to provide information regarding the crystallographic directions of wafer misorientation; however, this is beyond the scope of the present test method. Users desiring to carry out such interpretation should refer to Test Method E 82

and to DIN 50 433, Part 3, or to a standard X-ray textbook.<sup>2,3</sup> With different wafer holding fixturing, Test Method B is also applicable to determination of the orientation of a wafer surface.

1.5 The values stated in inch-pound units are to be regarded as the standard. The values given in parentheses are for information only.

1.6 *This standard does not purport to address all of the safety concerns, if any, associated with its use. It is the responsibility of the user of this standard to establish appropriate safety and health practices and determine the applicability of regulatory limitations prior to use.* For specific hazard statements see Section 6.

### 2. Referenced Documents

#### 2.1 ASTM Standards:

E 82 Test Method for Determining the Orientation of a Metal Crystal<sup>4</sup>

E 122 Practice for Choice of Sample Size to Estimate a Measure of Quality for a Lot or Process<sup>5</sup>

F 26 Test Methods for Determining the Orientation of a Semiconductive Single Crystal<sup>6</sup>

#### 2.2 Military Standard:

MIL-STD-105D Sampling Procedures and Tables for Inspection by Attributes<sup>7</sup>

#### 2.3 Other Standards:

Code of Federal Regulations, Title 10, Part 20, Standards for Protection Against Radiation<sup>8</sup>

SEMI Specification M 1, Polished Monocrystalline Silicon Slices<sup>9</sup>

DIN 50 433, Part 3, Testing of Materials for Semiconductor

<sup>2</sup> Wood, E. A., *Crystal Orientation Manual*, Columbia University Press, New York, NY, 1963.

<sup>3</sup> Barret, C. S., and Massalski, T. B., *The Structure of Metals*, 3rd edition McGraw-Hill, New York, NY, 1966.

<sup>4</sup> *Annual Book of ASTM Standards*, Vol 03.01.

<sup>5</sup> *Annual Book of ASTM Standards*, Vol 14.02.

<sup>6</sup> *Annual Book of ASTM Standards*, Vol 10.05.

<sup>7</sup> Available from Standardization Documents Order Desk, Bldg. 4 Section D, 700 Robbins Ave., Philadelphia, PA 19111-5094, Attn: NPODS.

<sup>8</sup> Published in Federal Register, Nov. 16, 1960. Available from Superintendent of Documents, U.S. Government Printing Office, Washington, DC 20402.

<sup>9</sup> Available from the Semiconductor Equipment and Materials Institute, Inc., 805 E. Middlefield Rd., Mountain View, CA 94043.

<sup>1</sup> These test methods are under the jurisdiction of ASTM Committee F01 on Electronics and are the direct responsibility of Subcommittee F01.06 on Silicon Materials and Process Control.

Current edition approved Aug. 15, 1994. Published October 1994. Originally published as F847 – 83. Last previous edition F847 – 87.

WAFER HOLDING FIXTURE

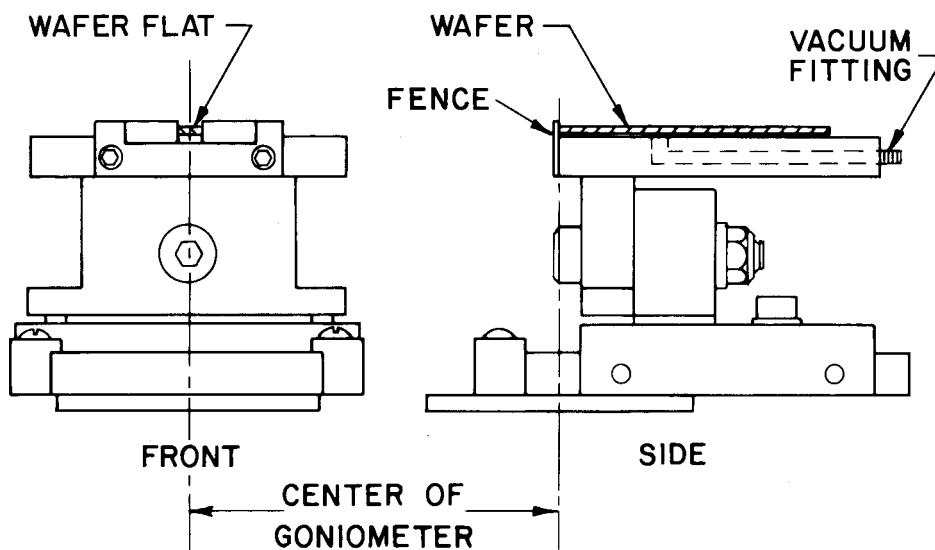

(a) Front and Side Views

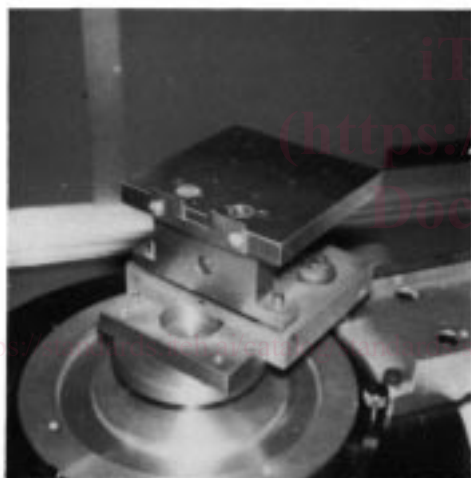

(b) Photograph of Mounted Fixture

WAFER REFERENCE FENCE

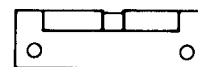
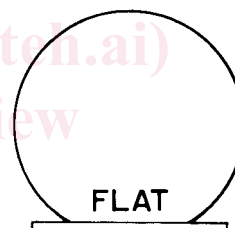

FRONT VIEW

(c) Detail of Wafer and Reference Fence

FIG. 1 Wafer Holding Fixture for X-Ray Edge Diffraction Method

Technology: Determining the Orientation of Single Crystals Using the Laue Back-Scattering Method<sup>6,10</sup>

3. Terminology

3.1 Definitions of Terms Specific to This Standard:

3.1.1 orientation—of a single crystal surface, the crystallographic plane, described in terms of its Miller indices, with which the surface is ideally coincident. The orientation of a wafer flat is the orientation of the surface of the flat (on the edge of the wafer). Flats are usually specified with respect to a

low-index plane, such as a {110} plane. In such cases the orientation of the flat may be described in terms of its angular deviation from the low-index plane.

4. Significance and Use

4.1 The orientation of flats on silicon wafers is an important materials acceptance requirement. The flats are used in semiconductor device processing to provide consistent alignment of device geometries with respect to crystallographic planes and directions.

4.2 Either one of these test methods is appropriate for process development and quality assurance applications. Until the interlaboratory precision of these test methods has been

<sup>10</sup> Available from Beuth Verlag GmbH Burggrafenstrasse 4-10, D-1000 Berlin 30, Germany.

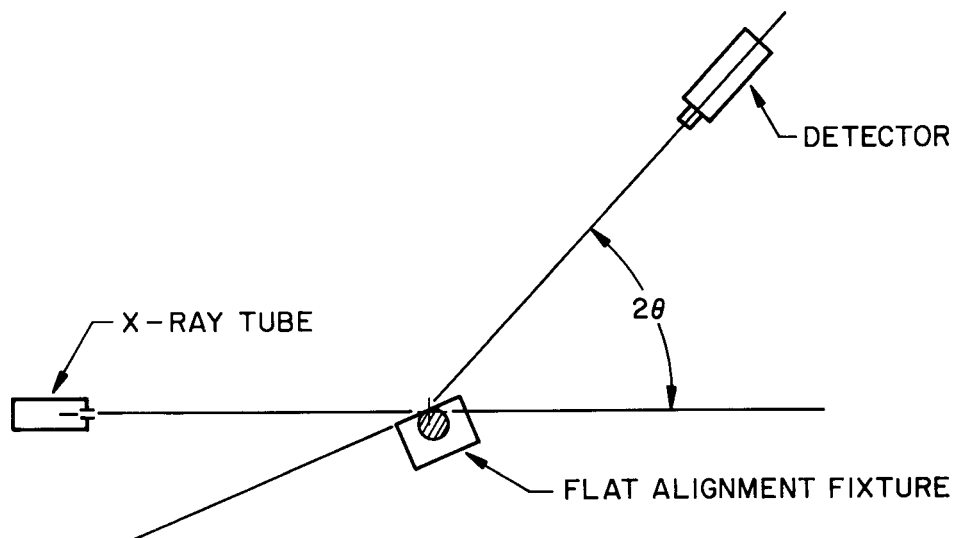

FIG. 2 Schematic of the Diffraction Geometry for the X-Ray Edge Diffraction Method

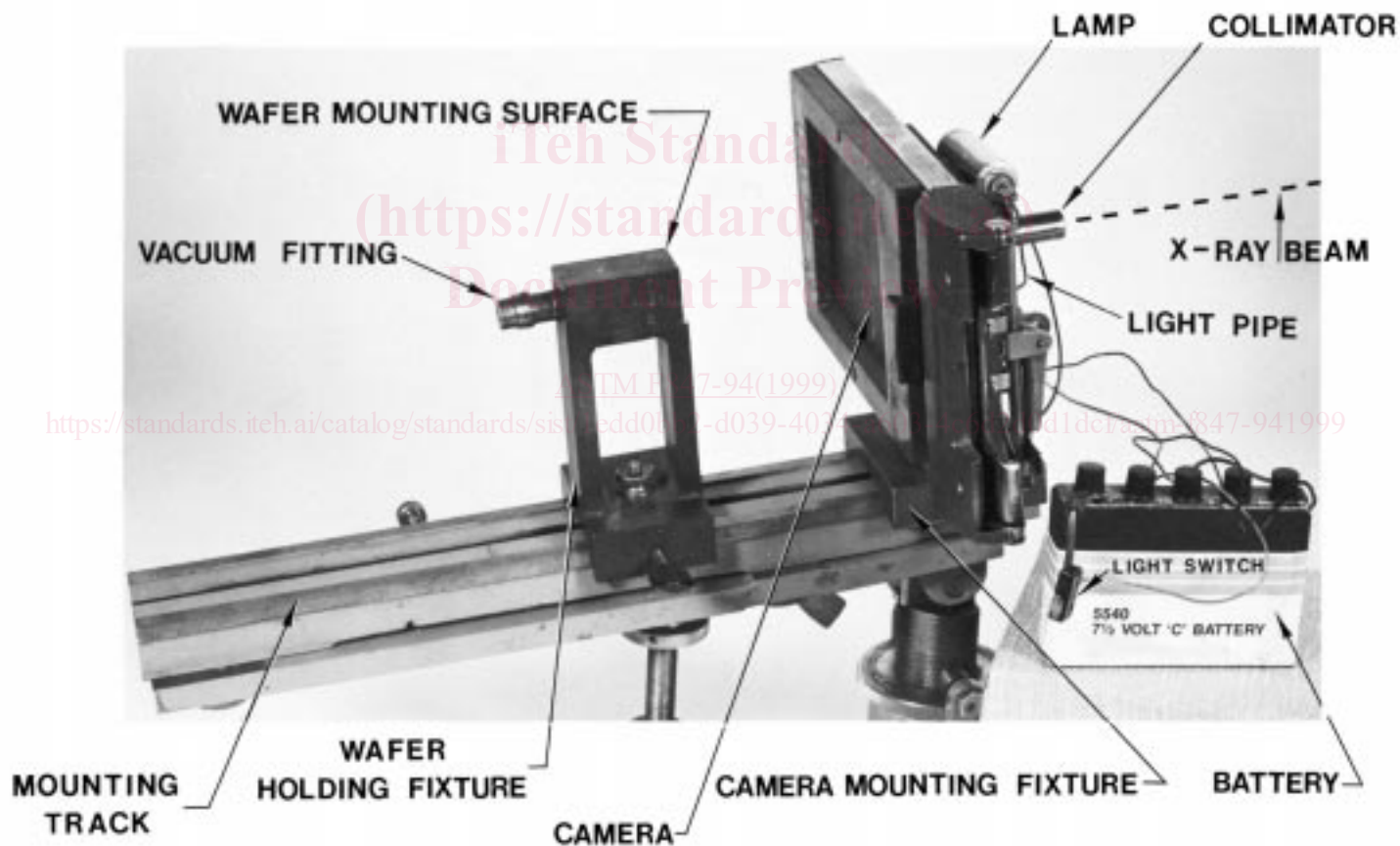

FIG. 3 Photograph of Assembled View of Laue Camera and Wafer Holder

determined, it is not recommended that they be used between supplier and purchaser.

**5. Interferences**

5.1 The alignment of the flat against the reference fence may be affected by the straightness of the flat. In the unlikely event that the flat profile is convex, the flat orientation may not

be unique. More often the flat surface will touch the reference fence along two lines perpendicular to the wafer surface at two points. In this case, the orientation determined will be that of the plane through the two lines on the plane perpendicular to the wafer surface which passes through the two points. In the latter cases, the orientation determined is that which will be

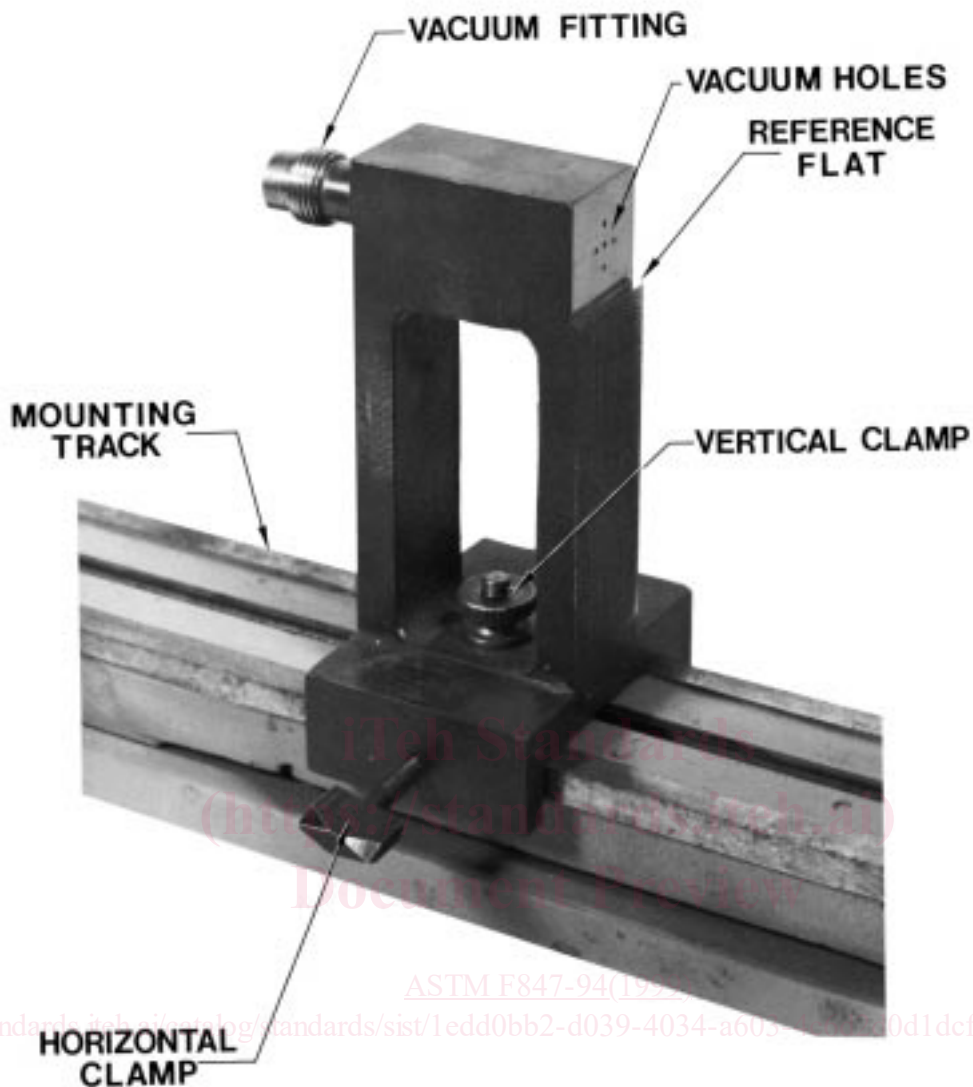

FIG. 4 Photograph of Wafer Holding Fixture and Mounting Track

obtained in subsequent processing of the wafer when the alignment is between the flat and a reference fence.

5.2 Misalignment of the various fixtures will degrade both the interlaboratory reproducibility and the absolute accuracy of both test methods. The single-instrument repeatability will not be degraded provided the fixturing is rigid.

## 6. Hazards

6.1 These test methods use X-radiation; it is absolutely necessary to avoid personal exposure to X rays. It is especially important to keep hands or fingers out of the path of the X rays and to protect the eyes from scattered secondary radiation. The use of commercial film badge or dosimeter service is recommended, together with periodic checks of the radiation level at the hand and body positions with a Geiger-Muller counter calibrated with a standard nuclear source. The present maximum permissible dose for total body exposure of an individual

to external X-radiation of quantum energy less than 3 MeV over an indefinite period is 1.25 R ( $3.22 \times 10^{-4}$  C/kg) per calendar quarter (equivalent to 0.6 mR/h ( $1.5 \times 10^{-7}$  C/kg-h)) as established in the *Code of Federal Regulations*, Title 10, Part 20. The present maximum permissible dose of hand and forearm exposure under the same conditions is 18.75 R ( $4.85 \times 10^{-3}$  C/kg) per calendar quarter (equivalent to 9.3 mR/h ( $2.4 \times 10^{-6}$  C/kg-h)). Besides the above stated regulations, various other government and regulatory organizations have their own safety requirements. It is the responsibility of the user to make sure that the equipment and the conditions under which it is used meet these regulations.

## 7. Sampling

7.1 Unless otherwise specified, Practice E 122 shall be used. When so specified, appropriate sample sizes shall be selected from each lot according to MIL-STD-105D. Inspection levels