



Designation: C349 – 14

Standard Test Method for Compressive Strength of Hydraulic-Cement Mortars (Using Portions of Prisms Broken in Flexure)¹

This standard is issued under the fixed designation C349; the number immediately following the designation indicates the year of original adoption or, in the case of revision, the year of last revision. A number in parentheses indicates the year of last reapproval. A superscript epsilon (ϵ) indicates an editorial change since the last revision or reapproval.

1. Scope*

1.1 This test method covers the determination of the compressive strength of hydraulic-cement mortars, using for the test specimens portions of prisms made and broken in flexure in accordance with Test Method C348.

1.2 The values stated in SI units are to be regarded as standard. No other units of measurement are included in this standard.

1.3 Values in SI units shall be obtained by measurement in SI units or by appropriate conversion, using the Rules for Conversion and rounding given in Standard IEEE/ASTM SI 10, of measurements made in other units.

1.4 *This standard does not purport to address all of the safety concerns, if any, associated with its use. It is the responsibility of the user of this standard to establish appropriate safety and health practices and determine the applicability of regulatory limitations prior to use. (Warning—Fresh hydraulic cementitious mixtures are caustic and may cause chemical burns to skin and tissue upon prolonged exposure.²)*

2. Referenced Documents

2.1 ASTM Standards:³

C109/C109M Test Method for Compressive Strength of Hydraulic Cement Mortars (Using 2-in. or [50-mm] Cube Specimens)

C348 Test Method for Flexural Strength of Hydraulic-Cement Mortars

C670 Practice for Preparing Precision and Bias Statements for Test Methods for Construction Materials

IEEE/ASTM SI 10 Standard for Use of the International System of Units (SI): The Modern Metric System

¹ This test method is under the jurisdiction of ASTM Committee C01 on Cement and is the direct responsibility of Subcommittee C01.27 on Strength.

Current edition approved Dec. 1, 2014. Published January 2015. Originally approved in 1954. Last previous edition approved in 2008 as C349–08. DOI: 10.1520/C0349-14.

² See the section on Safety, Manual of Cement Testing, *Annual Book of ASTM Standards*, Vol 04.01.

³ For referenced ASTM standards, visit the ASTM website, www.astm.org, or contact ASTM Customer Service at service@astm.org. For *Annual Book of ASTM Standards* volume information, refer to the standard's Document Summary page on the ASTM website.

3. Significance and Use

3.1 This method provides a means of obtaining compressive strength values from the same specimens previously used for flexural strength determinations by Test Method C348. The compressive strength values are for reference purposes, and not as substitutes for values obtained by Test Method C109/C109M for cement acceptance.

4. Apparatus

4.1 *Bearing Plates*—The bearing plates shall be ≥ 25 mm in thickness and shall be made of a hard metal. The surfaces of the bearing plates that are placed in contact with the specimens shall be 40.0 ± 0.1 -mm by 50.8-mm rectangles, with the 50.8-mm dimension at right angles to the longitudinal axis of the prism. The bearing plate surfaces in contact with the specimen shall have a Rockwell hardness of not less than 60 HRC. These surfaces shall not depart from plane surfaces by more than 0.01 mm when the plates are new and shall be maintained within a permissible variation of 0.03 mm.

4.2 *Device for Aligning Bearing Plates*—A device for aligning the bearing plates to ensure the proper location of the upper plate with reference to the lower plate is shown in Fig. 1. If the upper bearing plate does not have free movement within the aligning plates, these shall be separated from the bottom plate by insertion of 0.05-mm shims on each side of the bottom bearing plate, and the two 6-mm pins in the upper bearing plate filed down just sufficiently to permit free up and down movement in the slots at the top of the aligning plates.

4.3 *Testing Machine*—The testing machine shall conform to the requirements prescribed in Test Method C109/C109M, except that the testing machine shall be of the hydraulic type.

5. Test Specimens

5.1 Both portions from each prism broken in flexure shall be used for compression testing, except that the broken portions of prisms selected for the compression test shall have a length of not less than 65 mm and shall be free of cracks, chipped surfaces, or other obvious defects.

6. Procedure

6.1 *Determination of Compressive Strength*—During the interval between flexure tests of the prisms and testing the

*A Summary of Changes section appears at the end of this standard

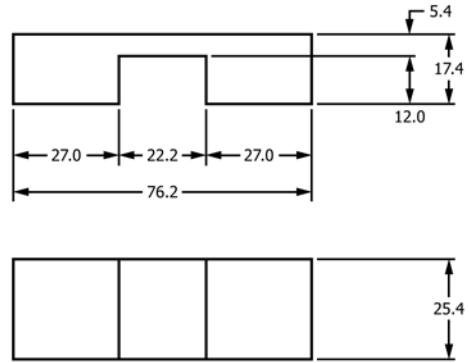
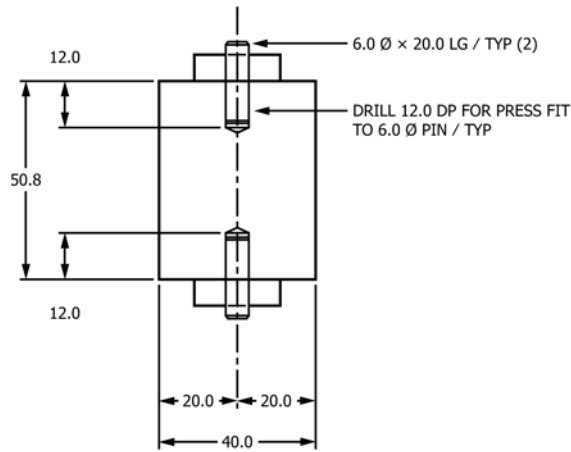

DETAIL / SPECIMEN CENTERING GUIDE
Scale: None

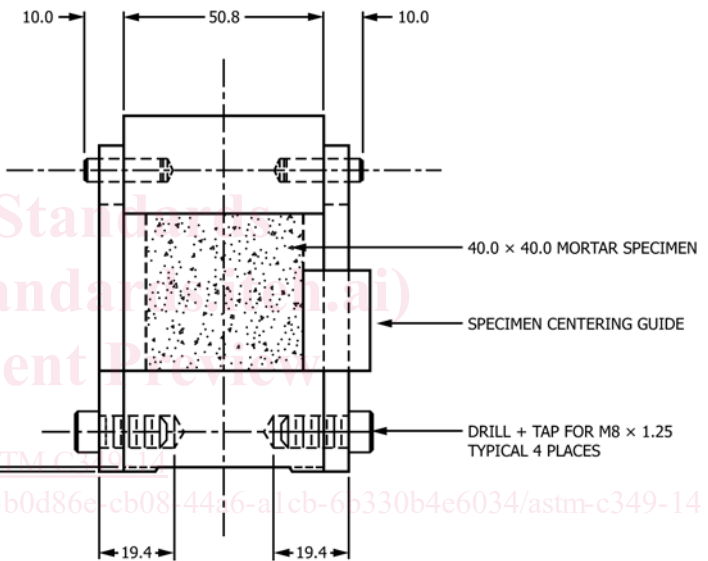
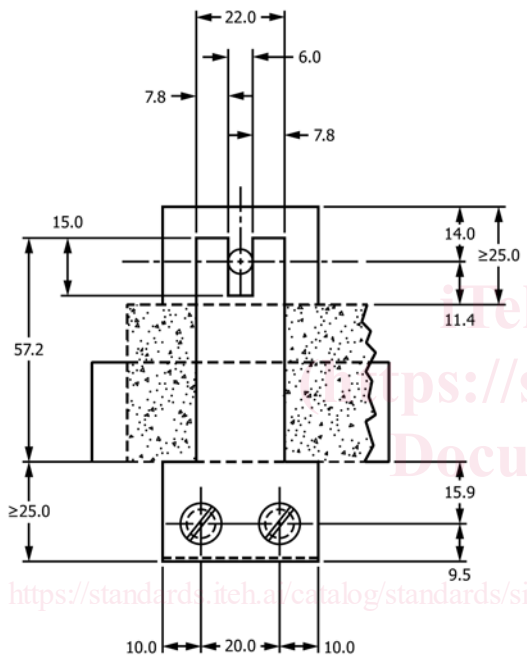

NOTES:
1. ALL DIMENSIONS EXPRESSED IN MILLIMETERS

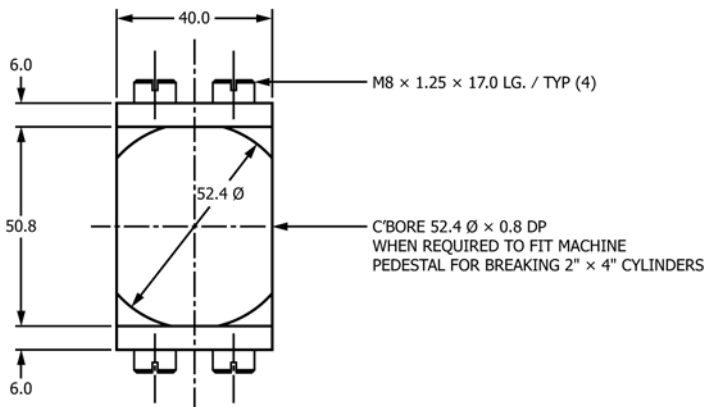

DETAIL / BEARING PLATES
Scale: None

FIG. 1 Bearing Plates and Bearing Plate Aligning Device for Testing 40 by 40 by 160-mm Mortar Prisms as Modified Cubes