



Designation: **D4254 – 00 (Reapproved 2006)^{ε1} D4254 – 14**

Standard Test Methods for Minimum Index Density and Unit Weight of Soils and Calculation of Relative Density¹

This standard is issued under the fixed designation D4254; the number immediately following the designation indicates the year of original adoption or, in the case of revision, the year of last revision. A number in parentheses indicates the year of last reapproval. A superscript epsilon (ϵ) indicates an editorial change since the last revision or reapproval.

This standard has been approved for use by agencies of the U.S. Department of Defense.

^{ε1} NOTE—Corrected research report reference in Section 12 editorially in March 2008.

1. Scope*

1.1 These test methods cover the determination of the minimum-index dry density/unit weight of cohesionless, free-draining soils. The adjective “dry” before density or unit weight is omitted in the title and remaining portions of this standards to be consistent with the applicable definitions given in Section 3 on Terminology.

1.2 System of units: Units:

1.2.1 The testing apparatus described in this standard has been developed and manufactured using values in the gravimetric or inch-pound system. Therefore, test apparatus dimensions and mass given in inch-pound units are regarded as the standard.

1.2.2 It is common practice in the engineering profession to concurrently use pounds to represent both a unit of mass (lbm) and a unit of force (lbf). This implicitly combines two separate systems of units; that is, the absolute system and the gravitational system. It is scientifically undesirable to combine the use of two separate sets of inch-pound units within a single standard. This test method has been written using the gravitational system of units when dealing with the inch-pound system. In this system, the pound (lbf) represents a unit of force (weight). However, balances or scales measure mass; and weight must be calculated. In the inch-pound system, it is common to assume that 1 lbf is equal to 1 lbm. While reporting density is not regarded as nonconformance with this standard, unit weights should be calculated and reported since the results may be used to determine force or stress.

1.2.3 The terms density and unit weight are often used interchangeably. Density is mass per unit volume, whereas unit weight is force per unit volume. In this standard, density is given only in SI units. After the density has been determined, the unit weight is calculated in SI or inch-pound units, or both.

1.3 Three alternative methods are provided to determine the minimum index density/unit weight, as follows:

1.3.1 Method A—Using a funnel pouring device or a hand scoop to place material in mold.

1.3.2 Method B—Depositing material into a mold by extracting a soil filled tube.

1.3.3 Method C²—Depositing material by inverting a graduated cylinder.

1.4 The method to be used should be specified by the ~~individual assigning agency requesting~~ the test. If no method is specified, the provisions of Method A shall govern. Test Method A is the preferred procedure for determining minimum index density/unit weight as used in conjunction with the procedures of Test Methods D4253. Methods B and C are provided for guidance of testing used in conjunction with special studies, especially where there is not enough material available to use a 0.100 ft³ (2830 cm³) or 0.500 ft³ (14 200 cm³) mold as required by Method A.

1.5 These test methods are applicable to soils that may contain up to 15 %, by dry mass, of soil particles passing a No. 200 (75- μ m) sieve, provided they still have cohesionless, free-draining characteristics (nominal sieve dimensions are in accordance with Specification E11).

1.5.1 Method A is applicable to soils in which 100 %, by dry mass, of soil particles pass a 3-in. (75-mm) sieve and which may contain up to 30 %, by dry mass, of soil particles retained on a 1½-inch (37.5-mm) sieve.

1.5.2 Method B is applicable to soils in which 100 %, by dry mass, of soil particles pass a ¾-inch (19.0-mm) sieve.

¹ This test method is under the jurisdiction of ASTM Committee D18 on Soil and Rock and is the direct responsibility of Subcommittee D18.03 on Texture, Plasticity and Density Characteristics of Soils.

Current edition approved Feb. 1, 2006 Dec. 15, 2014, Published March 2006 January 2015. Originally approved in 1983. Last previous edition approved in 2000 2006 as D4254 – 00: D4254 – 00 (2006)^{ε1}. DOI: 10.1520/D4254-00R06E01:10.1520/D4254-14.

² Kolbuszewski, J. J., “An Experimental Study of the Maximum and Minimum Porosities of Sands,” *Proceedings, Second International Conference on Soil Mechanics and Foundation Engineering*, Rotterdam Vol I, 1948, pp. 158–165.

*A Summary of Changes section appears at the end of this standard

1.5.3 Method C is applicable only to fine and medium sands in which 100 %, by dry mass, of soil particles pass a 3/8-in. (9.5-mm) sieve and which may contain up to 10 %, by dry mass, of soil particles retained on a No. 10 (2.00-mm) sieve.

1.5.4 Soils, for the purposes of these test methods, shall be regarded as naturally occurring cohesionless soils, processed particles, or composites or mixtures of natural soils, or mixtures of natural and processed particles, provided they are free-draining.

1.6 All observed and calculated values shall conform to the guidelines for significant digits and rounding established in Practice [D6026](#).

1.6.1 For purposes of comparing a measured or calculated value(s) to specified limits, the measured or calculated value(s) shall be rounded to the nearest decimal or significant digits in the specified limits.

1.6.2 The procedures used to specify how data are collected/recorded or calculated in this standard are regarded as the industry standard. In addition, they are representative of the significant digits that generally should be retained. The procedures used do not consider material variation, purpose for obtaining the data, special purpose studies, or any considerations for the user's objectives; and it is common practice to increase or reduce significant digits of reported data to be commensurate with these considerations. It is beyond the scope of this standard to consider significant digits used in analysis methods for engineering design.

1.7 *This standard does not purport to address all of the safety concerns, if any, associated with its use. It is the responsibility of the user of this standard to establish appropriate safety and health practices and determine the applicability of regulatory limitations prior to use.*

2. Referenced Documents

2.1 ASTM Standards:³

[C127](#) Test Method for Density, Relative Density (Specific Gravity), and Absorption of Coarse Aggregate

~~[D422](#) Test Method for Particle-Size Analysis of Soils~~

[D653](#) Terminology Relating to Soil, Rock, and Contained Fluids

[D854](#) Test Methods for Specific Gravity of Soil Solids by Water Pycnometer

~~[D1140](#) Test Methods for Determining the Amount of Material Finer than 75- μm (No. 200) Sieve in Soils by Washing~~

[D2216](#) Test Methods for Laboratory Determination of Water (Moisture) Content of Soil and Rock by Mass

[D2487](#) Practice for Classification of Soils for Engineering Purposes (Unified Soil Classification System)

[D2488](#) Practice for Description and Identification of Soils (Visual-Manual Procedure)

[D3740](#) Practice for Minimum Requirements for Agencies Engaged in Testing and/or Inspection of Soil and Rock as Used in Engineering Design and Construction

[D4253](#) Test Methods for Maximum Index Density and Unit Weight of Soils Using a Vibratory Table

[D4753](#) Guide for Evaluating, Selecting, and Specifying Balances and Standard Masses for Use in Soil, Rock, and Construction Materials Testing

[D6026](#) Practice for Using Significant Digits in Geotechnical Data

[D6913](#) Test Methods for Particle-Size Distribution (Gradation) of Soils Using Sieve Analysis

[E11](#) Specification for Woven Wire Test Sieve Cloth and Test Sieves

[E177](#) Practice for Use of the Terms Precision and Bias in ASTM Test Methods

[E691](#) Practice for Conducting an Interlaboratory Study to Determine the Precision of a Test Method

3. Terminology

3.1 *Definitions*—For common definitions in this standard refer to Terminology [D653](#).

3.2 *Definitions of Terms Specific to This Standard: Terms:*

3.2.1 *dry density/unit weight* ρ_d or γ_d , n —the dry density/unit weight of a soil deposit or fill at the given void ratio.

3.2.2 *given void ratio*, e , n —the in-situ or stated void ratio of a soil deposit or fill.

3.2.3 *maximum index density/unit weight*, $\rho_{d\text{dmax}}$ or $\gamma_{d\text{dmax}}$, n —the reference dry density/unit weight of a soil in the densest state of compactness that can be attained using a standard laboratory compaction procedure that minimizes particle segregation and breakdown.

3.2.4 *maximum-index void ratio*, e_{max} , n —the reference void ratio of a soil at the minimum index density/unit weight.

3.2.5 *minimum index density/unit weight* $\rho_{\text{demon}}\text{dmin}$ or $\gamma_{\text{diminishdmin}}$, n —reference dry density/unit weight of a soil in the loosest state of compactness at which it can be placed using a standard laboratory procedure that prevents bulking and minimizes particle segregation.

3.2.6 *minimum-index void ratio*, e_{min} , n —the reference void ratio of a soil at the maximum index density/unit weight.

³ For referenced ASTM standards, visit the ASTM website, www.astm.org, or contact ASTM Customer Service at service@astm.org. For *Annual Book of ASTM Standards* volume information, refer to the standard's Document Summary page on the ASTM website.

3.2.7 *relative density, D_d , n* —the ratio, expressed as a percentage, of the difference between the maximum index void ratio and any given void ratio of a cohesionless, free-draining soil to the difference between its maximum and minimum index void ratios. The equation is:

$$D_d = \frac{e_{\max} - e}{e_{\max} - e_{\min}} \times 100 \quad (1)$$

or, in terms of corresponding dry densities:

$$D_d = \frac{\rho_{d\max}(\rho_d - \rho_{d\min})}{\rho_d(\rho_{d\max} - \rho_{d\min})} \times 100 \quad (2)$$

3.2.7.1 Discussion—

The equation for relative density is:

$$D_d = \frac{e_{\max} - e}{e_{\max} - e_{\min}} \times 100 \quad (1)$$

or, in terms of corresponding dry densities:

$$D_d = ((\rho_{d\max}(\rho_d - \rho_{d\min})) / (\rho_d(\rho_{d\max} - \rho_{d\min}))) \times 100 \quad (2)$$

or, in terms of corresponding dry unit weights:

$$D_d = (\gamma_{d\max}(\gamma_d - \gamma_{d\min})) / (\gamma_d(\gamma_{d\max} - \gamma_{d\min})) \quad (3)$$

or, in terms of corresponding dry unit weights:

$$D_d = \frac{\gamma_{d\max}(\gamma_d - \gamma_{d\min})}{\gamma_d(\gamma_{d\max} - \gamma_{d\min})} \quad (3)$$

3.2.8 *density index/unit weight, I_d , n* —the ratio, expressed as a percentage, of the difference between any given dry density/unit weight and the minimum index density/unit weight of a given cohesionless soil to the difference between its maximum and minimum index densities/unit weights. The equation is:

$$I_d = \frac{\rho_d - \rho_{d\min}}{\rho_{d\max} - \rho_{d\min}} \times 100 \quad (4)$$

or, in terms of corresponding dry unit weights:

$$I_d = \frac{\gamma_d - \gamma_{d\min}}{\gamma_{d\max} - \gamma_{d\min}} \times 100 \quad (5)$$

3.2.8.1 Discussion—

The equation for density index/unit weight is:

$$I_d = ((\rho_d - \rho_{d\min}) / (\rho_{d\max} - \rho_{d\min})) \times 100 \quad (4)$$

or, in terms of corresponding dry unit weights:

$$I_d = ((\gamma_d - \gamma_{d\min}) / (\gamma_{d\max} - \gamma_{d\min})) \times 100 \quad (5)$$

4. Summary of Test Method

4.1 The minimum index density/unit weight represents the loosest condition of a cohesionless, free-draining soil that can be attained by a standard laboratory procedure, which prevents bulking and minimizes particle segregation. Any particular procedure selected will consist of determining All three methods determine the density/unit weight of oven-dried soil placed into a container of known volume in such a manner that prevents bulking and particle segregation, and minimizes compaction of the soil.

5. Significance and Use

5.1 The density/unit weight of a cohesionless soil may be determined by various in-place methods in the field or by the measurement of physical dimensions and masses by laboratory soil specimens. The dry density/unit weight of a cohesionless soil does not necessarily, by itself, reveal whether the soil is loose or dense.

5.2 Relative density/unit weight expresses the degree of compactness of a cohesionless soil with respect to the loosest and densest condition as defined by standard laboratory procedures. Only when viewed against the possible range of variation, in terms of relative density/unit weight, can the dry density/unit weight be related to the compaction effort used to place the soil in a compacted fill or indicate volume change and stress-strain tendencies of soil when subjected to external loading.

5.3 An absolute minimum density/unit weight is not necessarily obtained by these test methods.

NOTE 1—In addition, there are published data to indicate that these test methods have a high degree of variability.⁴ However, the variability can be greatly reduced by careful calibration of equipment, and careful attention to proper test procedure and technique.

5.4 The use of the standard molds (6.3.16.2.1) has been found to be satisfactory for most soils requiring minimum index density/unit weight testing. Special molds (6.3.26.2.2) shall only be used when the test results are to be applied in conjunction with design or special studies and there is not enough soil to use the standard molds. Such test results should be applied with caution, as minimum index densities/unit weights obtained with the special molds may not agree with those that would be obtained using the standard molds.

NOTE 2—The quality of the result produced by this standard is dependent on the competence of the personnel performing it, and the suitability of the equipment and facilities used. Agencies that meet the criteria of Practice D3740, generally, are considered capable of competent and objective testing/sampling/inspection/etc. Users of this standard are cautioned that compliance with Practice D3740 does not in itself assure reliable results. Reliable results depend on many factors; Practice D3740 provides a means of evaluating some of those factors.

6. Apparatus

6.1 Apparatus for Methods A, B, and C:

6.1.1 *Drying Oven*, thermostatically controlled, preferably of the forced-draft type, capable of maintaining a uniform temperature of $230 \pm 9^\circ\text{F}$ ($110 \pm 5^\circ\text{C}$) throughout the drying chamber.

6.1.2 *Sieves*, 3-in. (75-mm), 1½-in. (37.5-mm), ¾-in. (19-mm), ⅜-in. (9.5-mm), No. 4 (4.75-mm), No. 10 (2.00-mm), and No. 200 (75- μm) conforming to the requirements of Specification E11.

~~6.2 The apparatus for determining the minimum index density/unit weight of cohesionless soil by Methods A and B is specified in 6.3. Apparatus required for Method C is specified in 6.4.~~

6.2 Apparatus for Methods A and B:

6.2.1 *Standard Molds*—Cylindrical metal molds having nominal volumes of 0.1000 ft³ (2830 cm³) and 0.500 ft³ (14 200 cm³). The molds shall conform to the requirements shown in Fig. 1. The actual volume of the molds shall be within $\pm 1.5\%$ of the specified nominal volume.

6.2.2 *Special Molds*—Cylindrical metal molds having a capacity less than 0.100 ft³ (2830 cm³), an inside diameter equal to or greater than 2.75¾ in. (70 mm) but less than 4 in. (100 mm) and conforming to the design methodology presented in Fig. 2. Such molds may only be used when the test results are to be used in conjunction with design or special studies, and there is not enough soil to use the 0.100 ft³ (2830 cm³) mold.

6.2.3 *Balances(s)*, of sufficient capacity to determine the total mass of the specimen and mold, having sufficient accuracy that the mass of the soil is determined to the nearest 0.1 %. Balances capable of satisfying these requirements for most conditions have specifications as follows:

6.2.3.1 For 0.500-ft³ (14 200-cm³) molds, use a balance having a minimum capacity of 40-kg and meeting the requirements of Specification D4753 for a Class GP 10 (readability of 5 g).

6.2.3.2 For 0.100-ft³ (2830-cm³) molds, use a balance having a minimum capacity of at least 15 kg and meeting the requirements of Specification D4753 for Class GP 5 (readability of 1 g).

6.2.3.3 For special molds that are less than 0.1 ft³ (2830 cm³) in capacity, use a balance having a minimum capacity of at least 2 kg and meeting the requirements of Specification D4753 for a Class GP 2 (readability of 0.1 g).

6.2.4 *Pouring Devices*, are used in conjunction with the 0.100 ft³ (2830 cm³) standard mold and with special molds. Pouring devices consist of relatively rigid containers having volumes about 1.25 to 2 times greater than the volumes of the mold(s) used, and fitted with spouts or tubes about 6 in. (150 mm) long. Two pouring spouts are required, one having an inside spout diameter of 0.50 in. (13 mm) and another with an inside spout diameter of 1.0 in. (25 mm). A lipped brim, or other means, must be provided to securely connect the spout to the container that permits free and even flow of the soil from the container into the spout, and then into the mold.

6.2.5 *Rigid, Thin-Walled Tubes*, for use with Method B. The size of the tubes is dependent upon the mold size selected. The volume of the tubes shall be between 1.25 and 1.30 times the volume of the mold. The inside diameter of the tube shall be about 0.7 times the inside diameter of the mold.

6.2.6 Other equipment such as mixing pans, a large metal scoop, a hair-bristled dusting brush, and a metal straightedge (for trimming excess soil after it has been placed in the mold).

6.3 Apparatus for Method C:

6.3.1 *Glass Graduated Cylinder*, having a volume of 2000 mL, graduated to 20 mL, with about a 3-in. (75-mm) inside diameter.

6.3.2 *Balance*, of at least 2 kg capacity and otherwise consistent with 6.3.3.3.

6.3.3 *Sieves*, ⅜-in. (9.5-mm), No. 10 (2.00-mm), and No. 200 (75- μm) sieves conforming to the requirements of Specification E11.

⁴ Selig, E. T., and Ladd, R. S., eds., *Evaluation of Relative Density and its Role in Geotechnical Projects Involving Cohesionless Soils*, ASTM STP 523, ASTM, 1973.

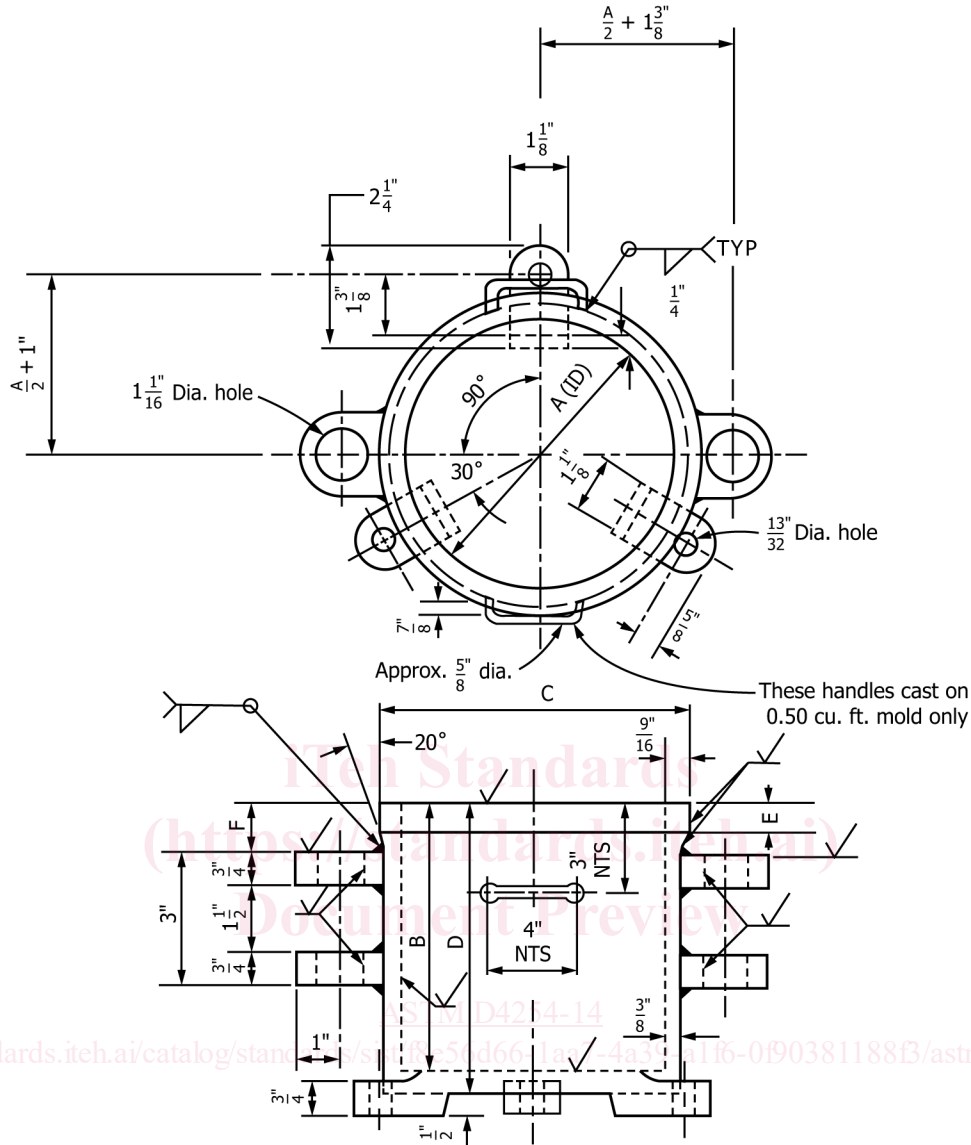

NOTE 1—Tolerances are $\pm 1/64$ in. (± 0.4 mm) unless otherwise noted.

| Size Mold, ft ³ (cm ³) | A | B | C | D | E | F |
|---|-------------------|------------------|-------------------------|------------------------|----------------------|-----------------------|
| 0.100 (2830) | $6.000 (152.4)$ | $6.112 (155.2)$ | $7\frac{1}{4} (181.0)$ | $6\frac{1}{2} (105.1)$ | $\frac{1}{2} (12.7)$ | $1\frac{1}{4} (28.6)$ |
| 0.100 (2830) | $6.000 (152.40)$ | $6.112 (155.24)$ | $7.13 (181.1)$ | $6.50 (165.1)$ | $0.50 (12.7)$ | $1.13 (28.7)$ |
| 0.500 (14 200) | $11.000 (279.4)$ | $9.092 (230.9)$ | $12\frac{1}{2} (308.0)$ | $9\frac{1}{2} (241.3)$ | $\frac{5}{8} (15.9)$ | $2 (50.8)$ |
| 0.500 (14 200) | $11.000 (279.40)$ | $9.092 (230.94)$ | $12.13 (308.0)$ | $9.50 (241.3)$ | $0.63 (16.0)$ | $2.00 (50.8)$ |

FIG. 1 Details of Molds

7. Sampling and Test Specimen

7.1 Prior to testing, the sample should be stored in a manner to prevent freezing, contamination with other matter, loss of soil, or loss of identification.

7.2 Sampling and test specimen requirements for Methods A and B are contained in the following paragraphs. Requirements for Method C begin at 7.4.

7.3 The required size (mass) of the test specimen and mold is a function of the maximum particle size contained in the sample and the particle-size distribution (gradation) of the sample (see Table 1).

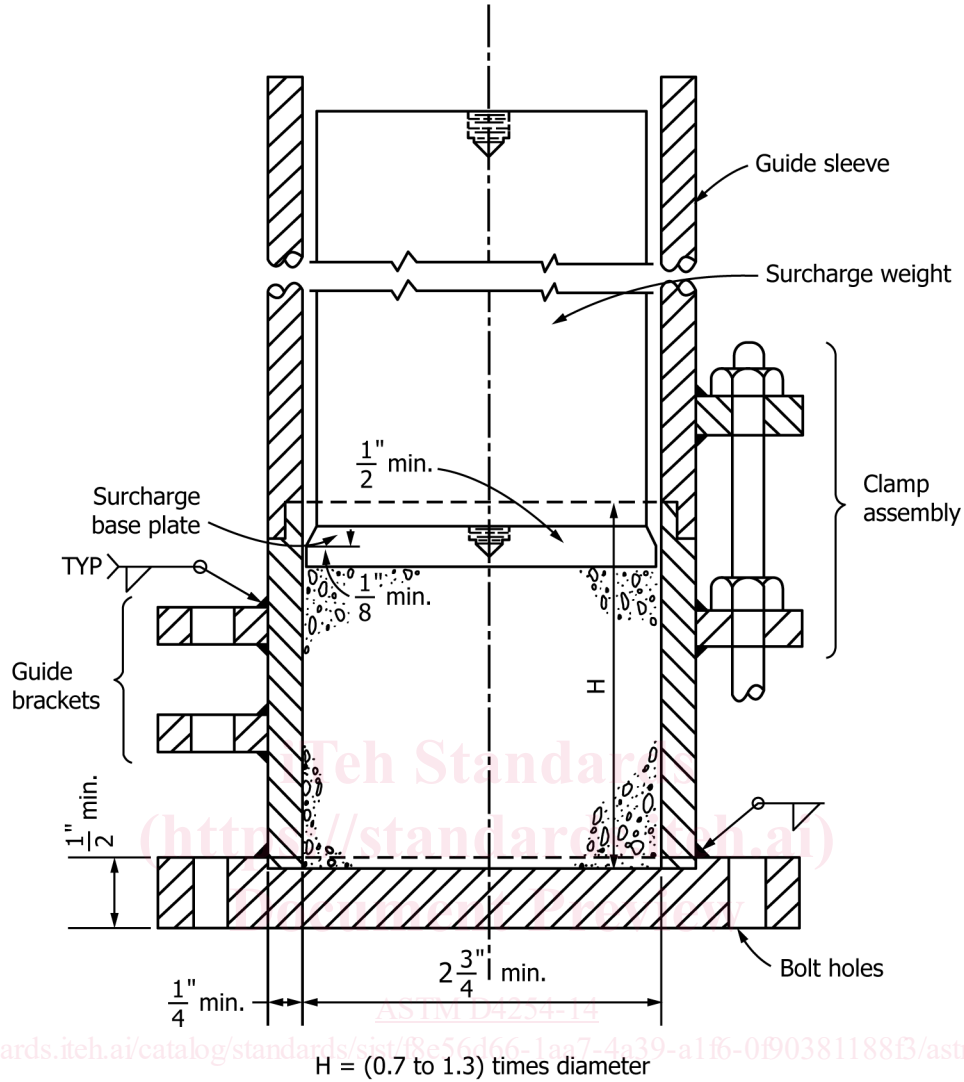

<https://standards.iteh.ai/catalog/standards/sist/8e56d66-1aa7-4a39-a1f6-0f90381188f3/astm-d4254-14>

| SD | Equivalents |
|-------|-------------|
| in. | mm |
| 1/8 | 3.2 |
| 0.125 | 3.2 |
| 1/4 | 6.4 |
| 0.25 | 6.4 |
| 1/2 | 13 |
| 0.50 | 13 |
| 3/4 | 19 |
| 2.75 | 70 |

FIG. 2 Special Cylindrical Metal Molds

TABLE 1 Required Mass of Specimen

| Maximum Size 100% Passing, in. (mm) | Mass of Specimen Required, kg | Placement Device to be Used in Minimum Density Test | Size of Mold to Be Used, ft ³ (cm ³) |
|--|----------------------------------|---|--|
| 3 (75) | 34 | shovel or extra large scoop | 0.500 (14 200) |
| 1 1/2 (38.1) | 34 | scoop | 0.500 (14 200) |
| 3/4 (19.0) | 11 | scoop | 0.100 (2830) |
| 3/8 (9.5) | 11 | pouring device with 1-in. (25-mm) diameter spout | 0.100 (2830) |
| No. 4 (4.75) or less | 11 | pouring device with 1/2-in. (13-mm) diameter spout | 0.100 (2830) |

7.3.1 Using a visual method or Test Method [D422D6913](#) (depending upon the complexity of the gradation of the sample and operator experience, determine the percentage of particles retained on the 3-in. (75-mm), 1 1/2-in. (37.5-mm), 3/4-in. (19.0-mm), 3/8-in. (9.5-mm), No. 4 (4.75-mm), No. 10 (2.00-mm), and No. 200 (75-μm) sieves.