INTERNATIONAL STANDARD



3601 / 1

INTERNATIONAL ORGANIZATION FOR STANDARDIZATION • МЕЖДУНАРОДНАЯ ОРГАНИЗАЦИЯ ПО СТАНДАРТИЗАЦИИ • ORGANISATION INTERNATIONALE DE NORMALISATION

**Fluid systems — O-rings —
Part 1 : Inside diameters, cross-sections, tolerances and size
identification code**

Transmissions hydrauliques et pneumatiques — Joints toriques — Partie 1 : Diamètres intérieurs, sections, tolérances et code d'identification dimensionnel.

ITeH STANDARD PREVIEW

First edition — 1978-08-15

(standards.iteh.ai)

ISO 3601-1:1978

<https://standards.iteh.ai/catalog/standards/sist/3652f574-6b9c-4a7d-96ec-840ef5dcd619/iso-3601-1-1978>

UDC 621.8.032 : 621-762.8

Ref. No. ISO 3601/1-1978 (E)

Descriptors : hydraulic equipment, pneumatic equipment, O-ring seals, specifications, designations, dimensions, dimensional tolerances.

Price based on 3 pages

FOREWORD

ISO (the International Organization for Standardization) is a worldwide federation of national standards institutes (ISO member bodies). The work of developing International Standards is carried out through ISO technical committees. Every member body interested in a subject for which a technical committee has been set up has the right to be represented on that committee. International organizations, governmental and non-governmental, in liaison with ISO, also take part in the work.

Draft International Standards adopted by the technical committees are circulated to the member bodies for approval before their acceptance as International Standards by the ISO Council.

International Standard ISO 3601/1 was developed by Technical Committee ISO/TC 131, *Fluid power systems and components*, and was circulated to the member bodies in June 1977.

Technical Standard Preview
(standards.iteh.ai)

It has been approved by the member bodies of the following countries :

Australia	France	Poland
Belgium	Germany	Romania
Brazil	Hungary	South Africa, Rep. of
Canada	Italy	Spain
Chile	Japan	Switzerland
Czechoslovakia	Mexico	U.S.A.
Egypt, Arab Rep. of	Netherlands	Yugoslavia

The member bodies of the following countries expressed disapproval of the document on technical grounds :

Finland
Sweden
United Kingdom
U.S.S.R.

This International Standard is a multi-part component standard for O-rings. It will be composed of the following parts :

Part I : Inside diameters, cross-sections, tolerances and size identification code.

Part II : Design criteria for standard applications.

Part III : Quality acceptance criteria.

In this part I, an attempt has been made to simplify by not allowing the International Standard to contain too many sizes for selection. The range of sizes was checked against production records. International Standard ISO 3 was used as the series of preferred numbers for inside diameters since it offered the most logical mathematical practice. Also, this automatically establishes the numbers that would be used if new sizes are added or inserted, and provides a convenient guideline for non-standard special sizes.

Current standards are lacking in some areas of the series sequence, causing many special sizes to be created in these areas. The logarithmic progression of the Renard series of ISO 3 eliminates the need for most of these special sizes.

The dimensions and tolerances given are suitable for any elastomeric material provided that appropriate tooling is used. The user is cautioned that the tooling most commonly available is based upon 70 IRHD NBR shrinkage rates.

iTeh STANDARD PREVIEW
(standards.iteh.ai)

<https://standards.iteh.ai/catalog/standards/sist/0925-1-001c-1a7d-96cc-840c15ccdb19/iso-3001-1-1978>

iTeh STANDARD PREVIEW
(standards.iteh.ai)

ISO 3601-1:1978

<https://standards.iteh.ai/catalog/standards/sist/3652f574-6b9c-4a7d-96ec-840ef5dcd619/iso-3601-1-1978>

Fluid systems – O-rings – Part 1 : Inside diameters, cross-sections, tolerances and size identification code

1 SCOPE AND FIELD OF APPLICATION

This International Standard (part 1) specifies the inside diameters, cross-sections, tolerances and size identification code for O-rings for fluid systems.

2 REFERENCES

ISO 3, *Preferred numbers – Series of preferred numbers.*

ISO 48, *Vulcanized rubbers – Determination of hardness (Hardness between 30 and 85 IRHD).*

ISO 1629, *Rubbers and latices – Nomenclature.*

ISO 5598, *Fluid power – Vocabulary.*¹⁾

<https://standards.iteh.ai/catalog/standards/sist/3652f574-6b9c-4a7d-96ec-840e5dcd619/iso-3601-1-1978>

3 DEFINITIONS

For definitions of terms used, see ISO 5598.

4 LETTER SYMBOLS

Letter symbols used are as follows :

d_1 = inside diameter

d_2 = section diameter

5 SHAPE

The O-ring is a toroidal shape, as shown in the figure.

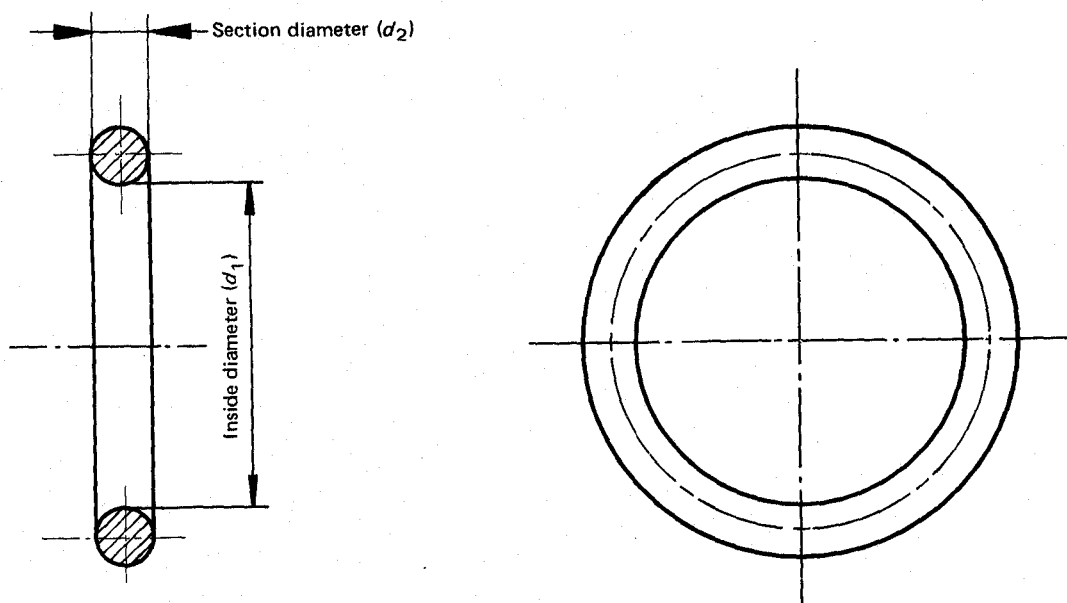

FIGURE – Typical O-ring

1) In preparation.

6 SELECTION OF INSIDE DIAMETERS, CROSS-SECTIONS AND THEIR TOLERANCES

For selection of combinations of inside diameters, cross-sections and their tolerances, see the table.

7 SIZE IDENTIFICATION CODE

7.1 Use a size code consisting of eight digits.

7.2 Use the numbers of the dimensions from the table but without decimal signs.

7.3 Use the first three digits to represent the section diameter (d_2), expressed in hundredths of a millimetre.

7.4 Use the next five digits to represent the internal diameter (d_1), expressed in hundredths of a millimetre.

7.5 Assume decimal signs to be after the first and sixth digits.

EXAMPLES :

Size code	d_2	d_1
18000355	= 1,80	× 3,55
26503450	= 2,65	× 34,5
35505000	= 3,55	× 50,0
53023000	= 5,30	× 230
70046200	= 7,00	× 462

NOTE — Non-standard sizes could use this same format without confusing them with standard sizes.

8 IDENTIFICATION STATEMENT (Reference to this International Standard)

Use the following statement in test reports, catalogues and sales literature when electing to comply with this International Standard :

"Inside diameters, cross-sections, tolerances and size identification code are in accordance with ISO 3601/1, *Fluid systems — O-rings — Part 1 : Inside diameters, cross-sections, tolerances and size identification code.*"

iTeh STANDARD PREVIEW (standards.iteh.ai)

[ISO 3601-1:1978](https://standards.iteh.ai/catalog/standards/sist/3652f574-6b9c-4a7d-96ec-840e5dcd619/iso-3601-1-1978)

<https://standards.iteh.ai/catalog/standards/sist/3652f574-6b9c-4a7d-96ec-840e5dcd619/iso-3601-1-1978>

iTeh STANDARD PREVIEW
(standards.iteh.ai)

ISO 3601-1:1978

<https://standards.iteh.ai/catalog/standards/sist/3652574-6b9c-4a7d-96ec-840e5dcd619/iso-3601-1-1978>