



Designation: **B329–06 (Reapproved 2012) B329 – 14**

## Standard Test Method for

# Apparent Density of Metal Powders and Compounds Using the Scott Volumeter<sup>1</sup>

This standard is issued under the fixed designation B329; the number immediately following the designation indicates the year of original adoption or, in the case of revision, the year of last revision. A number in parentheses indicates the year of last reapproval. A superscript epsilon ( $\epsilon$ ) indicates an editorial change since the last revision or reapproval.

*This standard has been approved for use by agencies of the U.S. Department of Defense.*

### 1. Scope\*

1.1 This test method covers determination of the apparent density of metal powders and related compounds using the Scott Volumeter, also known as the Paint Pigment Volumeter.

1.2 ~~The values~~ With the exception of the values for density and the mass used to determine density, for which the use of the gram per cubic centimetre ( $\text{g}/\text{cm}^3$ ) and gram (g) units is the longstanding industry practice, the values stated in SI units are to be regarded as the standard. ~~The values given in parentheses are for information only.~~

1.3 *This standard does not purport to address all of the safety concerns, if any, associated with its use. It is the responsibility of the user of this standard to establish appropriate safety and health practices and determine the applicability of regulatory limitations prior to use.*

### 2. Referenced Documents

2.1 *ASTM Standards:*<sup>2</sup>

[B215 Practices for Sampling Metal Powders](#)

[B243 Terminology of Powder Metallurgy](#)

[B873 Test Method for Measuring Volume of Apparent Density Cup Used in Test Methods B 212, B 329, and B 417](#)

### 3. Terminology

3.1 *Definitions*—For definitions of terms used in this test method see Terminology [B243](#).

### 4. Significance and Use

4.1 This test method covers the evaluation of the apparent density physical characteristic of powders. The degree of correlation between the results of this test and the quality of powders in use will vary with each particular application and has not been fully determined.

4.2 The apparent density measured via this test method is often referred to as the “Scott Density.”

### 5. Apparatus

5.1 **Fig. 1** shows the Scott Volumeter consisting of the following parts:

5.1.1 *Top Funnels*—A large funnel with a 16-mesh screen and a small conical funnel for directing the powder into the baffle box. Funnels and screen may be brass or stainless steel.

5.1.2 *Baffle Box*—A box with two glass sides and two wooden sides containing a series of four glass baffle plates.

The wooden baffle box may be substituted by a water-resistant material, such as stainless steel, if washing is more desirable than air cleaning.

<sup>1</sup> This test method is under the jurisdiction of ASTM Committee [B09](#) on Metal Powders and Metal Powder Products and is the direct responsibility of Subcommittee [B09.03](#) on Refractory Metal Powders.

Current edition approved Oct. 1, 2012; Dec. 1, 2014. Published October 2012; January 2015. Originally approved in 1958. Last previous edition approved in 2006 as B329 – 98 (2006); (2012). DOI: 10.1520/B0329-06R12; 10.1520/B0329-14.

<sup>2</sup> For referenced ASTM standards, visit the ASTM website, [www.astm.org](http://www.astm.org), or contact ASTM Customer Service at [service@astm.org](mailto:service@astm.org). For *Annual Book of ASTM Standards* volume information, refer to the standard's Document Summary page on the ASTM website.

\*A Summary of Changes section appears at the end of this standard

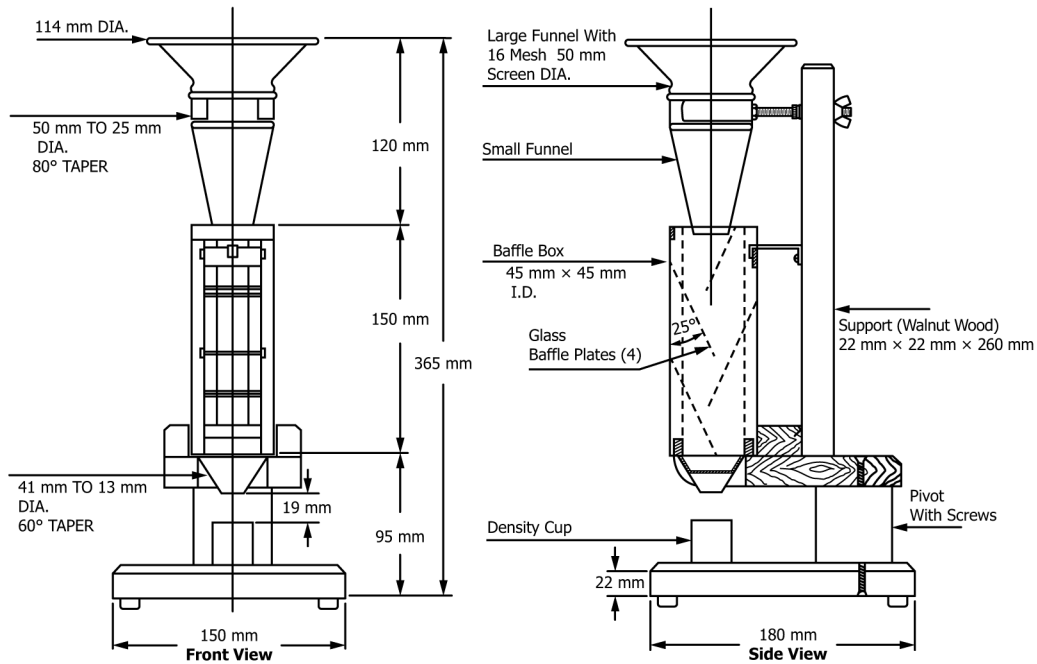

FIG. 1 Density Apparatus Assembly

5.1.3 *Bottom Funnel*—A small brass or stainless steel funnel directly beneath lower baffle box opening for directing the powder into the density cup.

5.1.4 *Density Cups*—A cylindrical cup having a capacity of  $25.00 \pm 0.03 \text{ cm}^3$ , with an inside diameter of  $28.00 \pm 0.50 \text{ mm}$ ;  $28.00 \pm 0.50 \text{ mm}$ ; or a square cup with a capacity of  $16.39 \pm 0.05 \text{ cm}^3$  ( $1.000 \pm 0.003 \text{ in.}^3$ ). Density cups may be either brass or stainless steel.

5.1.5 *Stand*—A  $90^\circ$  pivoting wooden or stainless steel stand to support the funnels and the baffle box concentric with the density cup so that the bottom funnel lower opening is 19 mm ( $\frac{3}{4} \text{ in.}$ ) above the top of the density cup as shown in Fig. 1 when using the cubic inch cup. Fig. 2 shows some suggested modifications for use of the metric cup. Modifications A and C of Fig. 2

ASTM B329/B329M-14

<https://standards.iteh.ai/catalog/standards/sist/b7677b3d-7e9e-4c08-b77c-f554e194736/astm-b329-b329m-14>

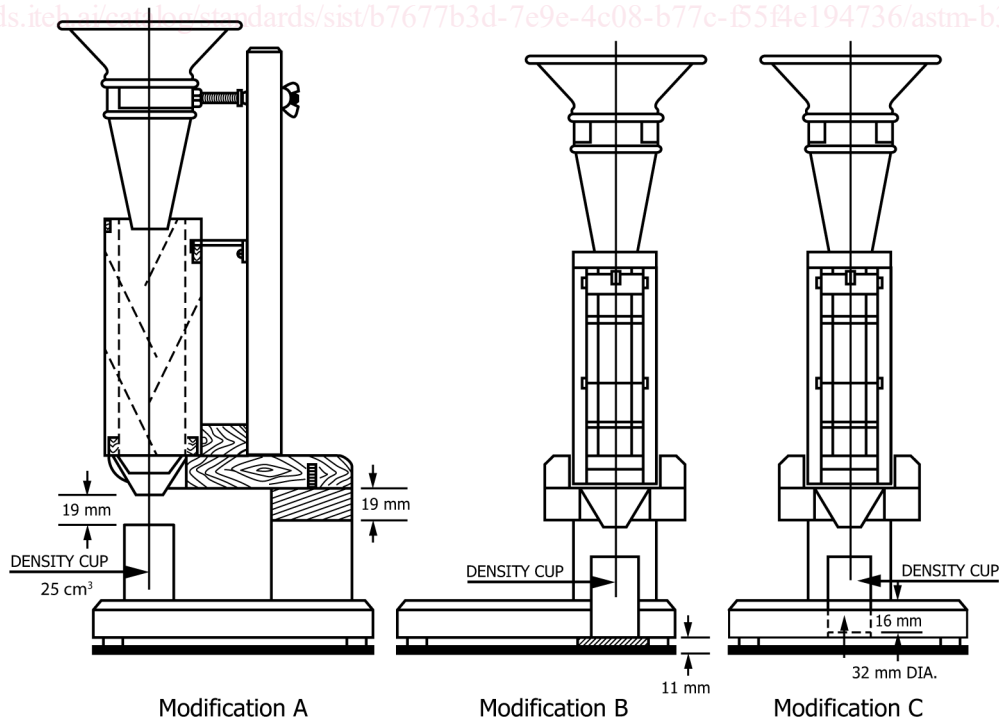

FIG. 2 Suggested Methods of Modifying the Wooden Scott Volumeter for Metric Density Cup