



Designation: **C215–08 C215 – 14**

Standard Test Method for Fundamental Transverse, Longitudinal, and Torsional Resonant Frequencies of Concrete Specimens¹

This standard is issued under the fixed designation C215; the number immediately following the designation indicates the year of original adoption or, in the case of revision, the year of last revision. A number in parentheses indicates the year of last reapproval. A superscript epsilon (ϵ) indicates an editorial change since the last revision or reapproval.

This standard has been approved for use by agencies of the U.S. Department of Defense.

1. Scope*

1.1 This test method covers measurement of the fundamental transverse, longitudinal, and torsional resonant frequencies of concrete prisms and cylinders for the purpose of calculating dynamic Young's modulus of elasticity, the dynamic modulus of rigidity (sometimes designated as "the modulus of elasticity in shear"), and dynamic Poisson's ratio.

1.2 The values stated in SI units are to be regarded as standard. No other units of measurement are included in this standard.

1.3 *This standard does not purport to address all of the safety concerns, if any, associated with its use. It is the responsibility of the user of this standard to establish appropriate safety and health practices and determine the applicability of regulatory limitations prior to use.*

2. Referenced Documents

2.1 *ASTM Standards:*²

[C31/C31M Practice for Making and Curing Concrete Test Specimens in the Field](#)

[C42/C42M Test Method for Obtaining and Testing Drilled Cores and Sawed Beams of Concrete](#)

[C125 Terminology Relating to Concrete and Concrete Aggregates](#)

[C192/C192M Practice for Making and Curing Concrete Test Specimens in the Laboratory](#)

[E469/C469/C469M Test Method for Static Modulus of Elasticity and Poisson's Ratio of Concrete in Compression](#)

[C670 Practice for Preparing Precision and Bias Statements for Test Methods for Construction Materials](#)

[E1316 Terminology for Nondestructive Examinations](#)

3. Terminology

3.1 *Definitions*—Refer to Terminology [C125](#) and the section related to ultrasonic examination in Terminology [E1316](#) for definitions of terms used in this test method.

4. Summary of Test Method

4.1 The fundamental resonant frequencies are determined using one of two alternative procedures: (1) the forced resonance method or (2) the impact resonance method. Regardless of which testing procedure is selected, the same procedure is to be used for all specimens of an associated series.

4.2 In the forced resonance method, a supported specimen is forced to vibrate by an electro-mechanical driving unit. The specimen response is monitored by a lightweight pickup unit on the specimen. The driving frequency is varied until the measured specimen response reaches a maximum amplitude. The value of the frequency causing maximum response is the resonant frequency of the specimen. The fundamental frequencies for the three different modes of vibration are obtained by proper location of the driver and the pickup unit.

4.3 In the impact resonance method, a supported specimen is struck with a small impactor and the specimen response is measured by a lightweight accelerometer on the specimen. The output of the accelerometer is recorded. The fundamental frequency

¹ This test method is under the jurisdiction of ASTM Committee [C09](#) on Concrete and Concrete Aggregates and is the direct responsibility of Subcommittee [C09.64](#) on Nondestructive and In-Place Testing.

Current edition approved Oct. 1, 2008; Dec. 15, 2014. Published November 2008; January 2015. Originally approved in 1947. Last previous edition approved in 2002; 2008 as [C215–02](#); [C215–08](#). DOI: [10.1520/C0215-08](#); [10.1520/C0215-14](#).

² For referenced ASTM standards, visit the ASTM website, [www.astm.org](#), or contact ASTM Customer Service at [service@astm.org](#). For *Annual Book of ASTM Standards* volume information, refer to the standard's Document Summary page on the ASTM website.

*A Summary of Changes section appears at the end of this standard

of vibration is determined by using digital signal processing methods or counting zero crossings in the recorded waveform. The fundamental frequencies for the three different modes of vibration are obtained by proper location of the impact point and the accelerometer.

5. Significance and Use

5.1 This test method is intended primarily for detecting significant changes in the dynamic modulus of elasticity of laboratory or field test specimens that are undergoing exposure to weathering or other types of potentially deteriorating influences. The test method may also be used to monitor the development of dynamic elastic modulus with increasing maturity of test specimens.

5.2 The value of the dynamic modulus of elasticity obtained by this test method will, in general, be greater than the static modulus of elasticity obtained by using Test Method C469C469/C469M. The difference depends, in part, on the strength level of the concrete.

5.3 The conditions of manufacture, the moisture content, and other characteristics of the test specimens (see section on Test Specimens) materially influence the results obtained.

5.4 Different computed values for the dynamic modulus of elasticity may result from widely different resonant frequencies of modes of vibration and from specimens of different sizes and shapes of the same concrete. Therefore, it is not advisable to compare results from different modes of vibration or from specimens of different sizes or shapes.

6. Apparatus

6.1 *Forced Resonance Apparatus (Fig. 1):*

6.1.1 *Driving Circuit*—The driving circuit shall consist of a variable frequency audio oscillator, an amplifier, and a driving unit. The oscillator shall be calibrated to read within ±2 % of the true frequency over the range of use (about 100 to 12 000 Hz). The combined oscillator and amplifier shall be capable of delivering sufficient power output to induce vibrations in the test specimen at frequencies other than the fundamental and shall be provided with a means for controlling the output. The driving unit for creating the vibration in the specimen shall be capable of handling the full power output of the oscillator and amplifier. The driving unit is used in contact with the test specimen or separated from the specimen by an air gap. When the test specimen is contact-driven, the vibrating parts of the driving unit shall be small in mass compared with that of the specimen. The oscillator and amplifier shall be capable of producing a voltage that does not vary more than ±20 % over the frequency range and, in combination with the driving unit, shall be free from spurious resonances that will be indicated in the output.

NOTE 1—It is recommended that the calibration of the variable frequency audio oscillator be checked periodically against signals transmitted by the National Institute of Standards and Technology radio station WWV, or against suitable electronic equipment such as a frequency counter, the calibration of which has been previously checked and found to be adequate.

6.1.2 *Pickup Circuit*—The pickup circuit shall consist of a pickup unit, an amplifier, and an indicator. The pickup unit shall generate a voltage proportional to the displacement, velocity, or acceleration of the test specimen, and the vibrating parts shall be small in mass compared with the mass so as to not affect the vibrational frequency of the test specimen by more than 1%. The pickup unit shall be free from spurious resonances in the normal operating range of 100 to 12 000 Hz. Either a piezoelectric or magnetic pickup unit meeting these requirements is acceptable. The amplifier shall have a controllable output of sufficient magnitude to actuate the indicator. The indicator shall consist of a voltmeter, milliammeter, or a voltmeter or a milliammeter that shows the relative amplitude of the signal from the pickup unit. The driver signal and the pickup signal shall be connected to the horizontal and vertical sweeps, respectively, of a real-time graphic display such as an oscilloscope or a data

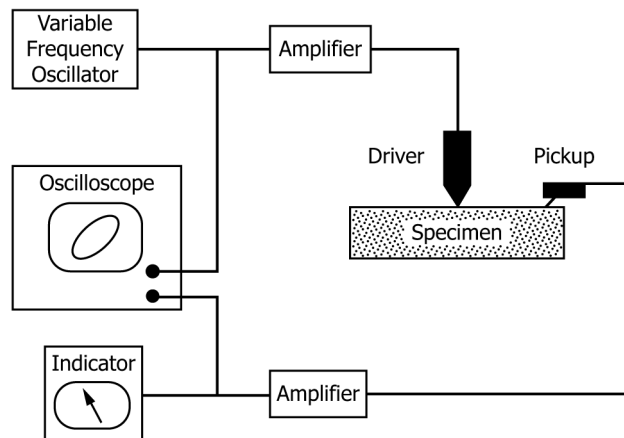

FIG. 1 Schematic of Apparatus for Forced Resonance Test

acquisition system with ~~monitor~~ (see monitor). The ~~Note 2~~ displayed pattern is used to confirm that the driver frequency at maximum signal amplitude is the resonant frequency of the specimen.

NOTE 2—For routine testing of specimens whose fundamental frequency may be anticipated to be within reasonable known limits, a meter-type indicator is satisfactory and may be more convenient to use than an oscilloscope or computer monitor for determining the fundamental resonant frequency. It is, however, strongly recommended that whenever feasible a graphic display be provided for supplementary use or to replace the meter-type indicator. The use of a graphic display as an indicator may be necessary when specimens are to be tested used. The graphic display will confirm that the specimen is vibrating at its fundamental resonant frequency, and is necessary when testing specimens for which the fundamental frequency range is unpredictable. The graphic display is not known beforehand. See Note 6 valuable also for checking the equipment for drift and for use in the event that it should be desired to use the equipment for certain other purposes than those specifically contemplated by this test method; for additional guidance on using the graphic display.

6.1.3 *Specimen Support*—The support shall permit the specimen to vibrate freely (Note 3). The ~~location~~ locations of the nodal points for the different modes of vibration are described in ~~Notes 6-8~~ Notes 4, 5, and 6. The support system shall be dimensioned so that its resonant frequency falls outside the range of use (from 100 to ~~10 000~~ 12 000 Hz).

NOTE 3—This may be accomplished by placing the specimen on soft rubber supports located near the nodal points or on a ~~thick pad of sponge rubber~~ sponge rubber pad.

6.2 *Impact Resonance Apparatus* (Fig. 2):

6.2.1 *Impactor*—The impactor shall be made of metal or rigid plastic and shall produce an impact duration that is sufficiently short to excite the highest resonant frequency to be measured. The manufacturer shall indicate the maximum resonant frequency that can be excited when the impactor strikes a concrete specimen with surfaces formed by a metal or plastic mold.

NOTE 4—~~A 19 mm~~ A 19-mm diameter solid steel ball mounted on a thin rod to produce a hammer is capable of exciting resonant frequencies up to about 10 kHz when impacting a smooth concrete surface. ~~A 110 g~~ 110 g steel ball peen hammer may act similarly. Larger steel balls will reduce the maximum resonant frequencies that can be excited. As an approximate guide, the maximum frequency that can be excited by the impact is the inverse of the impact duration.

6.2.2 *Sensor*—The sensor shall be a piezoelectric accelerometer with a mass less than 30 g and having an operating frequency range from 100 to ~~10 000~~ 15 000 Hz. The resonant frequency of the accelerometer shall be at least two times the maximum operating frequency.

6.2.3 *Frequency Analyzer*—Determine the frequency of the specimen vibration by using either a digital waveform analyzer or a frequency counter to analyze the signal measured by the sensor. The waveform analyzer shall have a sampling rate of at least ~~20 kHz~~ 2.5 times the maximum expected frequency to be measured and shall record at least ~~1024~~ 2048 points of the waveform. The frequency counter shall have an accuracy of $\pm 1\%$ over the range of use.

NOTE 5—The maximum frequency that can be measured using a digital waveform analyzer and the fast Fourier transform method is one-half the sampling frequency; for example, a sampling frequency of 30 kHz will allow measuring resonant frequencies up to 15 kHz. A sampling frequency of 2.5 times the expected frequency is called for in case the actual frequency exceeds the expected maximum frequency to be measured. The frequency resolution in the amplitude spectrum is the sampling frequency divided by the number of points in the waveform.

6.2.4 *Specimen Support*—Support shall be provided as specified in 6.1.3 for the forced resonance method.

7. Test Specimens

7.1 *Preparation*—Make the cylindrical or prismatic test specimens in accordance with Practice C192/C192M, Practice C31/C31M, Test Method C42/C42M, or other specified procedures.

7.2 *Measurement of Mass and Dimensions*—Determine the mass and average length of the specimens within $\pm 0.5\%$. Determine the average cross-sectional dimensions within $\pm 1\%$.

7.3 *Limitations on Dimensional Ratio*—Specimens having either small or large ratios of length to maximum transverse direction are frequently difficult to excite in the fundamental transverse mode of vibration. Best results are obtained when this ratio is between 3 and 5. For application of the formulas in this test method, the ratio must be at least 2. For measurement of longitudinal resonant frequency, the specimen shall have a circular or square cross-section and the length shall be at least two times the diameter for a cylinder or at least two times the side dimension for a prism.

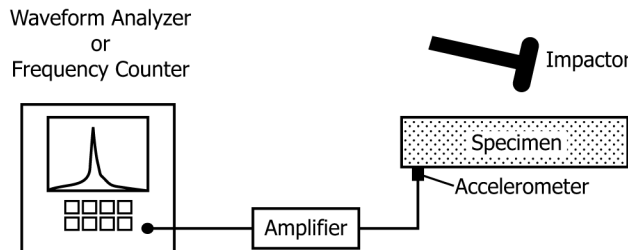

FIG. 2 Schematic of Apparatus for Impact Resonance Test

8. Determination of Resonant Frequencies—Forced Resonance Method

8.1 Transverse Frequency:

8.1.1 Support the specimen so that it is able to vibrate freely in the transverse mode (Note 56). Position the specimen and driver so that the driving force is perpendicular to the surface of the specimen. Locate the driving unit—driver at the approximate middle of the specimen—specimen as shown in Fig. 3a. Place the pickup unit on the specimen so that the direction of pickup sensitivity coincides with the vibration direction, that is, the transverse direction (see direction, Fig. 3a). Position the pickup near one end of the specimen. It is permissible to position the driver on the vertical face so that the specimen vibrates perpendicular to the direction shown in Fig. 3a.

8.1.2 Force the test specimen to vibrate at varying frequencies. At the same time, observe the indication of the amplified output of the pickup. If an oscilloscope or other graphic display is used, connect the driver signal to the horizontal sweep of the display and connect the pickup signal to the vertical sweep. Record the fundamental transverse frequency of the specimen, which is the frequency at which the indicator shows the maximum reading and observation of the graphic display or the nodal points indicates fundamental transverse vibration (Note 56). Adjust the amplifiers in the driving and pickup circuits to provide a satisfactory indication. To avoid distortion, maintain the driving force as low as is feasible for good response at resonance.

NOTE 6—For fundamental transverse vibration, the nodal points are located 0.224 of the length of the specimen from each end (approximately the quarter points). Vibrations are a maximum at the ends, approximately three fifths of the maximum at the center, and zero at the nodal points; therefore, movement of the pickup along the length of the specimen will inform the operator whether the vibrations observed in the indicator are from the specimen specimen is vibrating in its fundamental transverse mode. An oscilloscope or other graphic display may also be used to determine whether the specimen is vibrating in its fundamental transverse mode. The driver signal is connected to the horizontal sweep and the pickup signal is connected to the vertical sweep of the oscilloscope. When the pickup is located at the end of the specimen, which is vibrating in its fundamental transverse mode, the oscilloscope display will display show an inclined elliptical pattern. When the pickup is placed at a node, the oscilloscope display shows a horizontal line. When the pickup is placed at the center of the specimen, the display will be an elliptical pattern but inclined in the opposite direction to when the pickup was placed at the end of the specimen. The oscilloscope display can also be used to verify that the driving frequency is the fundamental resonant frequency. Resonance can occur when the driving frequency is a fraction of the fundamental frequency. In this case, however, the oscilloscope display pattern will not be an ellipse.

8.2 Longitudinal Frequency:

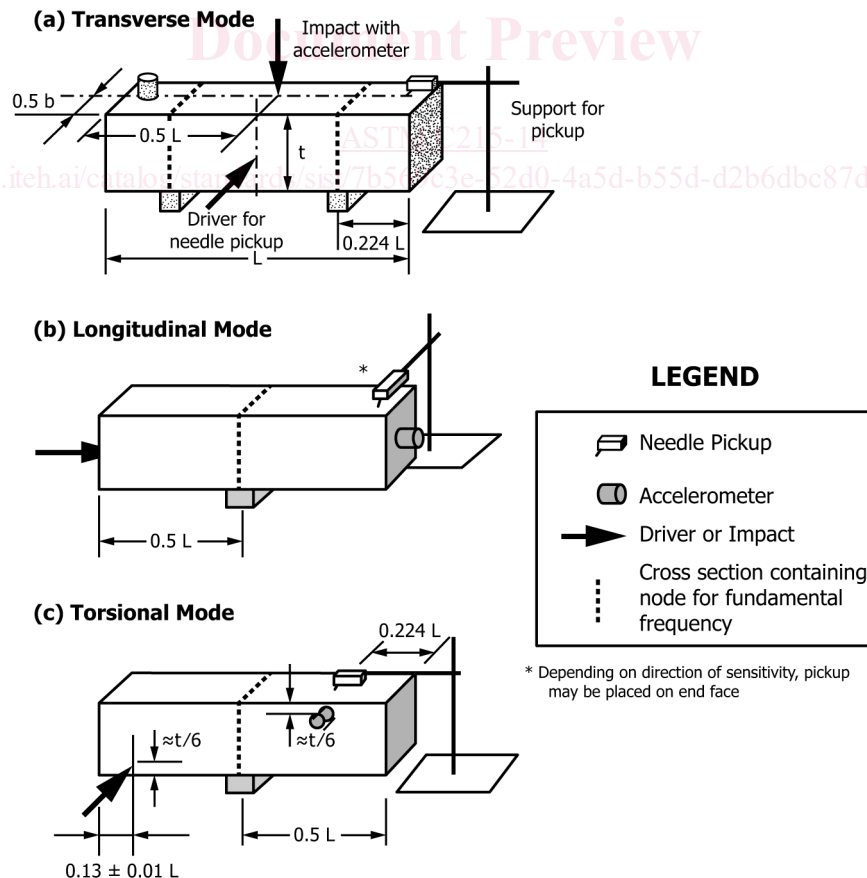

FIG. 3 Locations of Driver (or Impact) and Needle Pickup (or Accelerometer)