



Designation: C217/C217M – 15

Standard Test Method for Weather Resistance of Slate¹

This standard is issued under the fixed designation C217/C217M; the number immediately following the designation indicates the year of original adoption or, in the case of revision, the year of last revision. A number in parentheses indicates the year of last reapproval. A superscript epsilon (ϵ) indicates an editorial change since the last revision or reapproval.

1. Scope

1.1 This test method covers two procedures for weather resistance of slate in all outdoor installations by determining the depth of softening by shear/scratch tester or by hand scraping.

NOTE 1—The test is based on the fact that slates containing pyrite, calcite, and carbon undergo a chemical weathering which results in the conversion of the calcite particles to gypsum. The swelling action that results causes disintegration of the slate. The extent of this action on various slates in the test has been found to correlate with the durability of the materials in actual weathering.

1.2 *Units*—The values stated in either SI units or inch-pound units are to be regarded separately as standard. The values stated in each system may not be exact equivalents; therefore, each system shall be used independently of the other. Combining values from the two systems may result in non-conformance with the standard.

1.3 *This standard does not purport to address all of the safety concerns, if any, associated with its use. It is the responsibility of the user of this standard to establish appropriate safety and health practices and determine the applicability of regulatory limitations prior to use.*

2. Referenced Documents

2.1 *ASTM Standards*:²

C119 Terminology Relating to Dimension Stone

3. Terminology

3.1 *Definitions*—All definitions are in accordance with Terminology C119.

4. Significance and Use

4.1 This test method is useful in indicating the differences in weather resistance between various slates. This test method also provides one element in the comparison of slates.

¹ This test method is under the jurisdiction of ASTM Committee C18 on Dimension Stone and is the direct responsibility of Subcommittee C18.01 on Test Methods.

Current edition approved Jan. 15, 2015. Published February 2015. Originally approved in 1948. Last previous edition approved in 2009 as C217/C217M-09. DOI: 10.1520/C0217_C0217M-15.

² For referenced ASTM standards, visit the ASTM website, www.astm.org, or contact ASTM Customer Service at service@astm.org. For *Annual Book of ASTM Standards* volume information, refer to the standard's Document Summary page on the ASTM website.

5. Apparatus

5.1 Either one of the following shall be used:

5.1.1 *Shear/Scratch Tester*, (see Fig. 1) with the shear hardness tool, Model S-20³, or its equivalent. The apparatus includes a removable scale beam that is mounted on a pivotal shaft projecting from an adjustable gage block that can be raised or lowered, corresponding with the thickness of a test specimen up to 0.5 in. [12.7 mm]. The scale beam is set at an angle of 70° referencing the shaft it pivots on. A calibrated weight and sliding weight are mounted on the scale beam to achieve the desired load. Operated by an on/off switch, the motorized turntable rotates counter clockwise at a constant speed of 0.6 r/min.

5.1.2 *Hand Scraping Tool*—The scraping tool shall be made by grinding down the blade of a putty knife to a length of 3 in. [75 mm] and a width of ¾ in. [20 mm]. The end of the blade shall be ground to a plane surface perpendicular to the length of the tool to form a sharp edge with either side of the blade. These sharp edges will be referred to as the “cutting edges.”

6. Sampling

6.1 The samples shall be selected by the purchaser or his authorized representative so as to be truly representative of the consignment under consideration. Six shingles of roofing from each carload or fraction thereof or similar quantities from other kinds of slate shall constitute a sample.

NOTE 2—Six shingles 10 in. [250 mm] or more in length and of any standard width are sufficient for this test.

7. Test Specimens

7.1 Prepare at least three specimens, each 2 by 4 in. [50 by 100 mm] measured along the cleavage faces, for determining the depth of softening in a 1 % solution of sulfuric acid. The 2 by 4 in. [50 by 100 mm] faces shall be ground smooth and finished with No. 80 abrasive. Specimens cut from sheared or punched slate shall have no saw cut nearer than 1 in. [25 mm] from the edges or nail holes.

NOTE 3—While the minimum of three specimens is acceptable,

³ The sole source of supply known to the committee at this time is Taber Industries, North Tonawanda, NY. If you are aware of alternative suppliers, please provide this information to ASTM International Headquarters. Your comments will receive careful consideration at a meeting of the responsible technical committee,¹ which you may attend.

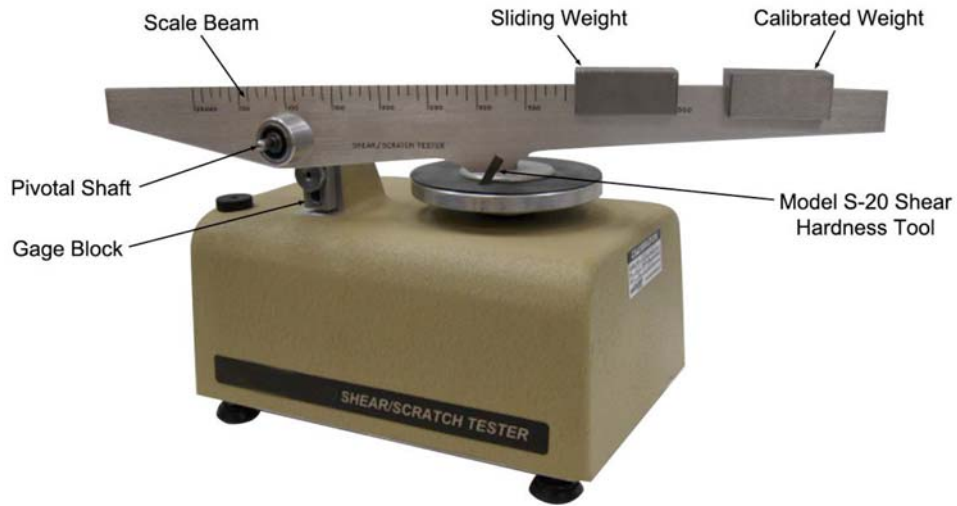

FIG. 1 Shear/Scratch Tester

evaluating six specimens per sample will provide greater confidence in your test results.

8. Procedure with Shear/Scratch Tester

8.1 In this procedure determine the depth of softening in acid with the shear/scratch tester (described in 5.1.1). The test involves measuring the depth of a groove made by the shearing tool in fresh specimens and also in the same specimens after soaking 7 days in 1 % sulfuric acid.

8.2 Draw with a pencil compass, on at least three of the 2 by 4 in. [50 by 100 mm] specimens, an arc of a circle of the same radius as that made by the shearing tool. Mark the arc at four points to identify the position for taking thickness measurements, as indicated in Fig. 2. Measure the thickness at each point to the nearest 0.0001 in. [0.002 mm].

NOTE 4—All measurements are to be taken normal to the surface of the specimen. In lieu of measuring specimen thickness before and after scraping, groove depth may be measured directly using surface metrology equipment.

8.3 With a 2.2 lbf [10 N] load on the shearing tool, groove each specimen along the penciled arc by rotating the turntable in a counter clockwise direction.

8.4 Repeat the thickness measurements at the same four points to determine the depth of groove made by the shearing tool.

8.5 Place the specimens in a glass vessel and completely cover with 1 % sulfuric acid solution. Space the specimens in the container so that the acid has free access to the 2 by 4 in. [50 by 100 mm] faces. Pour off the acid solution each day and

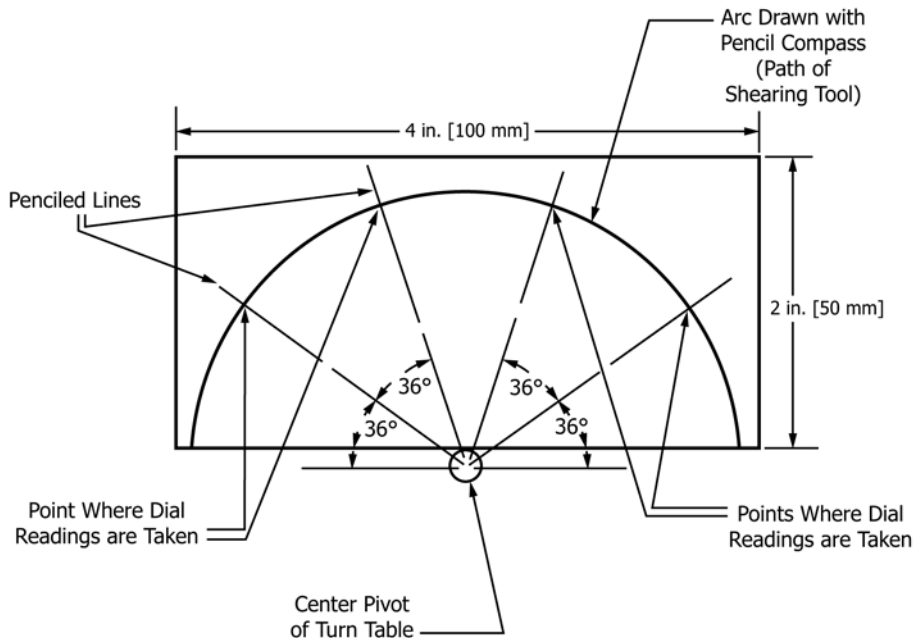

FIG. 2 Diagram of Slate Specimen Prepared for Test with Shear/Scratch Tester