



Designation: D5852 – 00(Reapproved 2007)<sup>ε1</sup>

## Standard Test Method for Erodibility Determination of Soil in the Field or in the Laboratory by the Jet Index Method<sup>1</sup>

This standard is issued under the fixed designation D5852; the number immediately following the designation indicates the year of original adoption or, in the case of revision, the year of last revision. A number in parentheses indicates the year of last reapproval. A superscript epsilon ( $\epsilon$ ) indicates an editorial change since the last revision or reapproval.

<sup>ε1</sup> NOTE—Editorially removed Note 2 in December 2014.

### 1. Scope

1.1 This test method covers the estimation of erodibility of a soil by a jet index method. This test method involves either preparing a field site or obtaining a relatively undisturbed soil sample and the subsequent activities for the determination of the erodibility of soil. This test method also may be run on compacted samples in the laboratory.

1.2 The values stated in SI units are to be regarded as the standard. The values given in parentheses are for information only.

1.3 *This standard does not purport to address all of the safety concerns, if any, associated with its use. It is the responsibility of the user of this standard to establish appropriate safety and health practices and determine the applicability of regulatory limitations prior to use.*

### 2. Referenced Documents

2.1 *ASTM Standards:*<sup>2</sup>

[D420 Guide to Site Characterization for Engineering Design and Construction Purposes \(Withdrawn 2011\)](#)<sup>3</sup>

[D653 Terminology Relating to Soil, Rock, and Contained Fluids](#)

[D2216 Test Methods for Laboratory Determination of Water \(Moisture\) Content of Soil and Rock by Mass](#)

[D2488 Practice for Description and Identification of Soils \(Visual-Manual Procedure\)](#)

[D3740 Practice for Minimum Requirements for Agencies Engaged in Testing and/or Inspection of Soil and Rock as Used in Engineering Design and Construction](#)

[D4220 Practices for Preserving and Transporting Soil Samples](#)

[D4753 Guide for Evaluating, Selecting, and Specifying Balances and Standard Masses for Use in Soil, Rock, and Construction Materials Testing](#)

### 3. Terminology

3.1 *Definitions:*

3.1.1 For common definitions of terms in this standard, refer to Terminology [D653](#).

### 4. Significance and Use

4.1 Water flow in nature exerts a force on soils that results in erosion. Erosion potential of a soil is of concern in vegetated channels, road embankments, dams, levees, spillways, construction sites, etc. The jet index method is intended to provide a standard method of expressing erosion resistance; to assist those who work with different soils and soil conditions to measure erosion resistance for design purposes; and to provide a common system of characterizing soil properties to develop performance and prediction relationships.

4.2 The jet index test is not suited for determining erodibility of soils that have structure characteristics larger than the scale of the jet testing device. For example, the erodibility of soil that has a dominant soil structure of 7 to 8 cm or larger (that is, aggregate, clod, or particle size), that might play a key role in the detachment process, should not be estimated with the jet index test. Care should be taken that the test sample and test are representative of expected conditions at the site under investigation. If it is known in advance that the soil will be saturated prior to an erosion event, then the soil should be tested in that condition. At present, the effects of water chemistry on detachment rate are unknown. Therefore, water quality during testing should be simulated as close as possible to the water quality anticipated during actual erosion.

NOTE 1—The quality of the result produced by this standard is depend upon the competence of the personnel performing it, and the suitability of the equipment and facilities used. Agencies that meet the criteria of Practice [D3740](#) are generally considered capable of competent and objective testing and sampling. Users of this standard are cautioned that compliance with Practice [D3740](#) does not in itself assure reliable results.

<sup>1</sup> This test method is under the jurisdiction of ASTM Committee [D18](#) on Soil and Rock and is the direct responsibility of Subcommittee [D18.02](#) on Sampling and Related Field Testing for Soil Evaluations.

Current edition approved July 1, 2007. Published August 2007. Originally approved in 1995. Last previous edition approved in 2000 as D5852 – 00. DOI: 10.1520/D5852-00R07E01.

<sup>2</sup> For referenced ASTM standards, visit the ASTM website, www.astm.org, or contact ASTM Customer Service at service@astm.org. For *Annual Book of ASTM Standards* volume information, refer to the standard's Document Summary page on the ASTM website.

<sup>3</sup> The last approved version of this historical standard is referenced on www.astm.org.

Reliable results depend on many factors; Practice D3740 provides a means of evaluating some of those factors.

## 5. Apparatus

### 5.1 Field Testing:

5.1.1 *Vertical Submerged Jet Device*—An apparatus that can be taken to the field to index soil erodibility (see Fig. 1). The device is mounted on a base ring with a sealing ring to prevent leakage and piping. A cylindrical tank is attached to the base ring to act as a weir while maintaining the water level required to submerge the jet. The soil surface inside the device is 0.44 m in diameter. Attached to the tank is an inner cylindrical liner that acts as a baffle to minimize return turbulence to the jet. The jet and pin profiler (see Fig. 2 and Fig. 3) are interchangeable and are mounted to the upper surface of this liner. A 51-mm diameter clear acrylic tube, the lower end of which is fitted with a 13-mm diameter nozzle, is mounted in a hanger that can be set on the inner cylindrical liner.

5.1.2 *Pin Profiler*, used to determine the maximum depth of material removed during testing.

5.1.3 *Water Delivery System*, required to run the jet test. Water delivery may be accomplished by pumping directly from a body of water at the site, from a storage tank delivered to the site, or from a city water supply system if available.

5.1.4 *Differential Pressure Device*, necessary in order to determine the mean velocity at the jet nozzle. This may be accomplished by manometers, differential pressure gage, or pressure transducer.

5.1.5 *Pressure Control*, necessary to maintain a constant velocity at the jet nozzle. This may be accomplished by a constant head tank or a valve.

5.1.6 *Level*—A carpenters level is necessary to level the foundation ring and inner liner of the tank.

5.1.7 *Shovel*—A flat-nosed shovel is useful in preparing the site for testing.

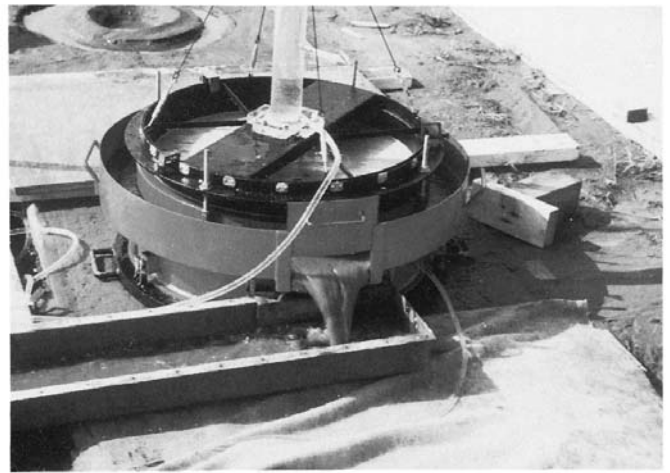

FIG. 2 Jet Apparatus in Operation

5.1.8 *Ruler*—A ruler is required to set the jet nozzle at a height of 0.22 m above the unscoured soil surface.

5.1.9 *Miscellaneous Equipment*—A 10 to 13 cm diameter flat disk, sledgehammer, wrenches, plastic bags and other soil sampling equipment for other soil tests of interest.

### 5.2 Laboratory Testing:

5.2.1 *Vertical Submerged Jet Device*—An apparatus that is used in the laboratory to determine soil erodibility (see Fig. 4). The device consists of a lower cylindrical tank that slides under a fixed upper cylindrical tank. The upper and lower cylindrical tanks are sealed together with an inflated tube to prevent leakage during testing. The sample is loaded into the lower tank and slid under the upper tank. The upper tank acts as a weir while maintaining the water level required to submerge the jet. The soil samples are contained in pvc molds with an inner diameter of 0.44 m and a height of 0.18 m. Attached to

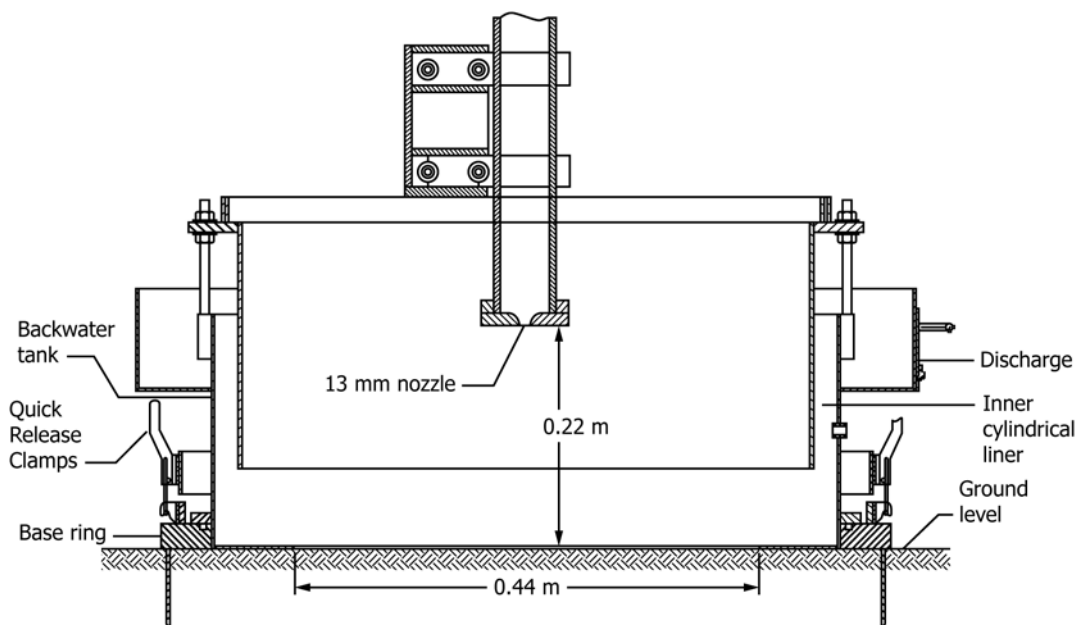

FIG. 1 Submerged Jet Apparatus for Field Testing

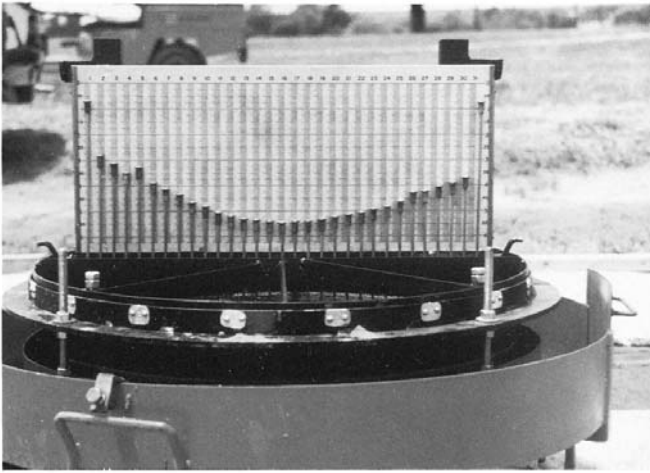

FIG. 3 Pin Profile Following a Time Sequence

delivery, differential pressure control and measurement are necessary for both the laboratory device and for the field testing device.

5.2.9 *Miscellaneous Equipment*—A 10 to 13 cm diameter flat disk, sledgehammer, plastic bags, cans, gloves, wrenches and ruler.

## 6. Procedure

### 6.1 Field Testing:

6.1.1 Prepare the surface at the test location so that it is reasonably level and void of vegetation. When the site is ready for testing, push the base ring into the soil. This may require the use of a sledgehammer, impacting on a wood cushion (such as a two by four) to protect the base ring from damage. The base ring should then be checked to make sure it is relatively level.

6.1.2 Set the backwater tank in place over the base ring and latch down. Place the cylindrical liner on the leveling bolts of the backwater tank and level. Use the pin profiler to determine the pre-testing soil elevation. Pre-set the pin profiler on the jet device so that only minor nozzle adjustments are necessary at the beginning of the test. Do this by placing it in a 5 gal (about 19 L) bucket near the same elevation as the backwater tank and make necessary adjustments to the head differential on the nozzle. Although other head settings may be used, the recommended head setting on the jet is 0.91 m (36 in.). Remove the pin profiler and backfill the tank with water. Place the jet apparatus on the backwater tank cylindrical liner. Hold a flat 10 to 13 cm diameter disk approximately 3 cm from the nozzle outlet and make final adjustments to the head. The flat disk prevents discharge from the nozzle from impinging directly on the sample prior to testing. Remove the disk from the discharging jet to initiate testing. A timing sequence of 600, 1200, 1800, and 3600 s intervals is recommended for a total testing time of 7200 s. Other timing sequences are at the discretion of the user. A pin profile of the surface of the tested soil sample shall be taken after each time sequence (see Fig. 3). Following testing, equipment clean up is essential.

6.1.3 Before testing, the inner cylinder should be made level and the nozzle jet height should be set at 0.22 m above the surface of the soil sample. Before testing begins, the fluid head on the jet should be set close to 0.91 m so that only minor adjustments are necessary at start up of testing.

### 6.2 Laboratory Testing:

6.2.1 Pre-set the head on the jet device. Load the sample into the lower tank and slide the sample under the upper tank. Pressurize the sealing tube between the upper and lower cylinders of the testing apparatus.

6.2.2 Use the pin profiler to determine the pretesting soil elevation. Remove the pin profiler and backfill the tank with water. Place the jet apparatus on the backwater tank cylindrical liner. Hold a flat 10 to 13 cm diameter disk approximately 3 cm from the nozzle outlet and make final adjustments to the head. The flat disk prevents discharge from the nozzle from impinging directly on the sample prior to testing. Remove the disk from the discharging jet to initiate testing. A test timing sequence of 600, 1200, 1800, and 3600 s intervals is recommended for a total testing time of 7200 s. Other timing

the tank is an inner cylindrical liner that acts as a baffle to minimize return turbulence to the jet. The jet and pin profiler are interchangeable, mounted to the upper surface of this liner. A 51-mm diameter clear acrylic tube, the lower end of which is fitted with a 13-mm diameter nozzle, is mounted in a hanger that can be set on the inner cylindrical liner.

5.2.2 *Mold*—A large mold is required for obtaining relatively undisturbed samples from the field. Due to the size of the samples required, pvc molds are recommended to minimize the mass of the sample. The mold size recommended consists of 0.44 m inner diameter and 0.18 m height. Once a mold sample is obtained in the field, it should be immediately covered at both ends with stiff plastic disks held firmly with a framing system. Sampling and preserving/transporting soils samples are done in accordance with Guide D420 and Practice D4220 respectively.

5.2.3 *Cutting Head*—A cutting head is essential for taking samples this size in the field. The cutting head is mounted to the front end of the mold and driven in or pushed in advance of the mold. The procedure for obtaining a sample is to advance the mold and cutting head 5 to 8 cm at a time, remove the material around the outside of the mold and repeat the process until the mold is to the desired depth.

5.2.4 *Straight Edge*—A straight edge is necessary to trim both ends of the sample flush with the mold.

5.2.5 *Shovel*—Any one of several types of shovels or spades is satisfactory for shallow sampling when digging around the mold.

5.2.6 *Balances*—All balances shall meet the requirements of Specification D4753 and this section. A balance or scale of at least 100 kg capacity is required for determining the mass of the mold and sample. A balance or scale of 500 g capacity is required to determine field water content of disturbed samples.

5.2.7 *Drying Equipment*—Equipment and oven are required to determine water content. Water contents shall be determined in accordance with Test Method D2216.

5.2.8 *Water Delivery System, Differential Pressure Device, and Pressure Control*—Equipment necessary for water