



Designation: C506 – 15

Standard Specification for Reinforced Concrete Arch Culvert, Storm Drain, and Sewer Pipe¹

This standard is issued under the fixed designation C506; the number immediately following the designation indicates the year of original adoption or, in the case of revision, the year of last revision. A number in parentheses indicates the year of last reapproval. A superscript epsilon (ϵ) indicates an editorial change since the last revision or reapproval.

This standard has been approved for use by agencies of the U.S. Department of Defense.

1. Scope

1.1 This specification covers reinforced arch-shaped concrete pipe to be used for the conveyance of sewage, industrial wastes, storm water, and for the construction of culverts.

1.2 This specification is the inch-pound companion to C506M; therefore, no SI equivalents are presented in the specification.

NOTE 1—This specification is a manufacturing and purchase specification only, and does not include requirements for bedding, backfill, or the relationship between field load condition and the strength classification of pipe. However, experience has shown that the successful performance of this product depends upon the proper selection of the class of pipe, type of bedding and backfill, and care that the installation conforms to the construction specifications. The owner of the reinforced concrete pipe specified herein is cautioned that he must correlate the field requirements with the class of pipe specified and provide inspection at the construction site.

2. Referenced Documents

2.1 ASTM Standards:²

- A36/A36M Specification for Carbon Structural Steel
- A615/A615M Specification for Deformed and Plain Carbon-Steel Bars for Concrete Reinforcement
- A706/A706M Specification for Deformed and Plain Low-Alloy Steel Bars for Concrete Reinforcement
- A1064/A1064M Specification for Carbon-Steel Wire and Welded Wire Reinforcement, Plain and Deformed, for Concrete
- C33 Specification for Concrete Aggregates
- C150 Specification for Portland Cement
- C260 Specification for Air-Entraining Admixtures for Concrete

¹ This specification is under the jurisdiction of ASTM Committee C13 on Concrete Pipe and is the direct responsibility of Subcommittee C13.02 on Reinforced Sewer and Culvert Pipe.

Current edition approved Jan. 1, 2015. Published January 2015. Originally approved in 1963. Last previous edition approved in 2014 as C506 – 14. DOI: 10.1520/C0506-15.

² For referenced ASTM standards, visit the ASTM website, www.astm.org, or contact ASTM Customer Service at service@astm.org. For *Annual Book of ASTM Standards* volume information, refer to the standard's Document Summary page on the ASTM website.

- C309 Specification for Liquid Membrane-Forming Compounds for Curing Concrete
- C494/C494M Specification for Chemical Admixtures for Concrete
- C497 Test Methods for Concrete Pipe, Manhole Sections, or Tile
- C595 Specification for Blended Hydraulic Cements
- C618 Specification for Coal Fly Ash and Raw or Calcined Natural Pozzolan for Use in Concrete
- C822 Terminology Relating to Concrete Pipe and Related Products
- C989 Specification for Slag Cement for Use in Concrete and Mortars
- C1017/C1017M Specification for Chemical Admixtures for Use in Producing Flowing Concrete
- C1116 Specification for Fiber-Reinforced Concrete and Shotcrete
- C1602/C1602M Specification for Mixing Water Used in the Production of Hydraulic Cement Concrete

3. Terminology

3.1 *Definitions*—For definitions of terms relating to concrete pipe, see Terminology C822.

4. Classification

4.1 Pipe manufactured according to this specification shall be of three classes identified as Class A-II, A-III, and A-IV. The strength requirements are prescribed in Table 1.

5. Basis of Acceptance

5.1 Unless otherwise designated by the owner at the time of, or before placing an order, there are two separate and alternative bases of acceptance. Independent of the method of acceptance, the pipe shall be designed to meet both the 0.01-in. crack and ultimate strength requirements.

5.1.1 *Acceptance on Basis of Plant Load Bearing Tests, Material Tests, and Inspection of Manufactured Pipe for Visual Defects and Imperfections*—Acceptability of the pipe in all diameters and classes produced in accordance with 7.1 or 7.2, shall be determined by the results of the three-edge-bearing tests as defined in 11.3.1; by such material tests as are required

TABLE 1 Strength Requirements for Reinforced Concrete Pipe^A

Approximate Equivalent Round Size, in.	T, in.	Minimum Rise, in.	Minimum Span, in.	Double Line Reinforcement ^C																			
				$f'c,^B$ MPA														Single Line Reinforcement					
				Continuous Basic Reinforcement = A_s^D														Additional Reinforcement = A_s^D					
				Class			Inner Cage			Outer Cage			"U" (Inner Cage)			"V" (Outer Cage)							
A-II	A-III	A-IV	A-II	A-III	A-IV	A-II	A-III	A-IV	A-II	A-III	A-IV	Dimension, in.	A-II	A-III	A-IV	Dimension, in.	A-II	A-III	A-IV				
15	2¼	11	18	4	4	4	0.08	0.12	0.17	
18	2½	13½	22	4	4	4	0.11	0.14	0.26	
21	2¾	15½	26	4	4	4	0.12	0.17	0.29	
24	3	18	28½	4	4	4	0.16	0.21	0.32	
30	3½	22½	36¼	4	4	4	0.09	0.12	0.18	0.07	0.09	0.14	26	0.09	0.12	0.18	29	0.07	0.09	0.12	0.18	0.24	0.36
36	4	26¾	43¾	4	4	4	0.11	0.15	0.21	0.09	0.12	0.17	30	0.11	0.15	0.21	34	0.09	0.12	0.16	0.21	0.30	0.44
42	4½	31⅝	51⅝	4	4	4	0.12	0.18	0.27	0.10	0.14	0.21	34	0.12	0.18	0.27	39	0.10	0.14	0.21	0.26	0.36	0.54
48	5	36	58½	4	4	...	0.15	0.21	...	0.12	0.17	...	42	0.15	0.21	...	43	0.12	0.17	...	0.30	0.44	...
54	5½	40	65	4	4	...	0.18	0.24	...	0.14	0.19	...	48	0.18	0.24	...	49	0.14	0.19	...	0.36	0.48	...
60	6	45	73	4	4	...	0.21	0.27	...	0.17	0.21	...	52	0.21	0.27	...	55	0.17	0.21	...	0.42	0.56	...
72	7	54	88	4	5	...	0.26	0.36	...	0.20	0.27	...	60	0.26	0.36	...	67	0.20	0.27	...	0.52	0.72	...
84	8	62	102	4	5	...	0.32	0.44	...	0.24	0.34	...	68	0.32	0.44	...	77	0.24	0.34	...	0.64	0.88	...
90	8½	72	115
96	9	77½	122
108	10	87½	138
120	11	96¾	154
132	10	106½	168¾

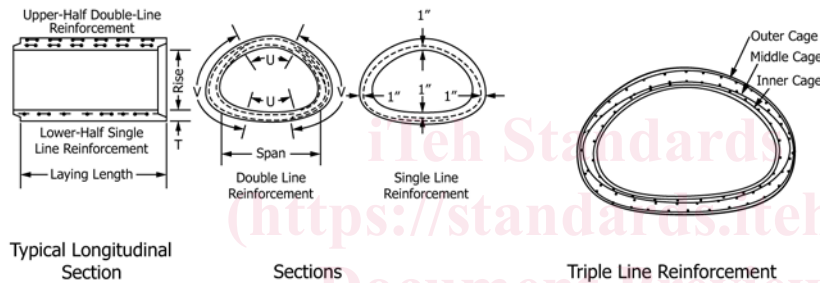

D-Loads for 3-Edge-Bearing Method		
Class	0.01-in. Crack	Ultimate
II	1000	1500
III	1350	2000
IV	2000	3000

Note—Test load in pounds per linear foot equals D-load x inside span in feet.

^AFor modified or special designs, see 7.3.

^B $f'c, ksi$ = minimum compressive strength of concrete in thousands of pounds-force per square inch.

^CAs an alternative to designs requiring double line reinforcement, the reinforcement may be positioned and proportioned so that the total reinforcement of the inner cage plus the middle cage shall not be less than that specified for the inner cage continuous basic reinforcement, and the additional reinforcement "U" and the total reinforcement of the outer cage plus the middle cage shall not be less than that specified for the outer cage continuous basic reinforcement and the additional reinforcement "V."

^D A_s = circumferential steel area in square inches per longitudinal foot of pipe barrel in each continuous basic cage and additional cages in area denoted "U" and "V." Dimensions "U" and "V" are measured on the center line of the culvert wall.

in accordance with 6.2, 6.3, 6.5, and 6.6, by an absorption test of the concrete from the wall of the pipe as required in 11.9; and by visual inspection of the finished pipe to determine its conformance with the accepted design and its freedom from defects.

5.1.2 *Acceptance on Basis of Material Tests and Inspection of Manufactured Pipe for Defects and Imperfections*—Acceptability of the pipe in all diameters and classes produced in accordance with 7.1 or 7.2 shall be determined by the results of such material tests as are required in 6.2, 6.3, 6.5, and 6.6; by crushing tests on concrete cores or cured concrete cylinders; by an absorption test of the concrete from the wall of the pipe for each mix design that is used on an order; and by inspection of the finished pipe, including amount and placement of reinforcement, to determine its conformance with the accepted design and its freedom from defects.

5.1.3 When agreed upon by the owner and the manufacturer, any portion or any combination of the tests itemized in 5.1.1 or 5.1.2 may form the basis of acceptance.

5.2 *Age for Acceptance*—Pipe shall be considered ready for acceptance when they conform to the requirements as indicated by the specified tests.

6. Materials

6.1 The aggregate shall be so sized, graded, proportioned, and mixed with such proportions of portland cement, blended hydraulic cement, or portland cement and supplementary cementing materials, or admixtures, or a combination thereof, if used, and water to produce a homogeneous concrete mixture of such quality that the pipe will conform to the test and design requirements of this specification. In no case, however, shall the proportion of portland cement, blended hydraulic cement, or a combination of portland cement and supplementary cementing materials be less than 470 lb/yd³.

6.2 Cementitious Materials:

6.2.1 *Cement*—Cement shall conform to the requirements of Specification C150, or shall be portland blast-furnace slag

cement, or slag modified portland cement, or portland-pozzolan cement conforming to the requirements of Specification C595, except that the pozzolan constituent in the Type IP portland-pozzolan cement shall be fly ash.

6.2.2 *Ground Granulated Blast-Furnace Slag (GGBFS)*—GGBFS shall conform to the requirements of Grade 100 or 120 of Specification C989.

6.2.3 *Fly Ash*—Fly ash shall conform to the requirements of Class F or Class C of Specification C618.

6.2.4 *Allowable Combinations of Cementitious Materials*—The combination of cementitious materials used in the concrete shall be one of the following:

- 6.2.4.1 Portland cement only,
- 6.2.4.2 Portland blast furnace slag cement only,
- 6.2.4.3 Portland pozzolan cement only,
- 6.2.4.4 A combination of portland cement and ground granulated blast-furnace slag,
- 6.2.4.5 A combination of portland cement and fly ash,
- 6.2.4.6 A combination of portland cement, ground granulated blast-furnace slag, and fly ash, or
- 6.2.4.7 A combination of portland pozzolan cement and fly ash.

6.3 *Aggregates*—Aggregates shall conform to Specification C33 except that the requirement for gradation shall not apply.

6.4 *Admixtures and Blends*—The following admixtures and blends are allowable:

6.4.1 Air-entraining admixture conforming to Specification C260;

6.4.2 Chemical admixture conforming to Specification C494/C494M;

6.4.3 Chemical admixture for use in producing flowing concrete conforming to Specification C1017/C1017M; and

6.4.4 Chemical admixture or blend approved by the owner.

6.5 *Steel Reinforcement*—Reinforcement shall conform to the requirements of Specification A1064/A1064M, or bars conforming to Specification A36/A36M, Specification A615/A615M Grade 40 or 60, or Specification A706/A706M Grade 60. For helically wound cages only, weld shear tests are not required.

6.6 *Synthetic Fibers*—Collated fibrillated virgin polypropylene fibers may be used, at the manufacturer's option, in concrete pipe as a nonstructural manufacturing material. Only Type III synthetic fibers designed and manufactured specifically for use in concrete and conforming to the requirements of Specification C1116 shall be accepted.

7. Design

7.1 *Size and Dimensions*—The standard sizes of arch pipe are listed in Table 1. The internal dimensions for each standard size shall be as defined in Fig. 1, subject to the permissible variations of Section 12.

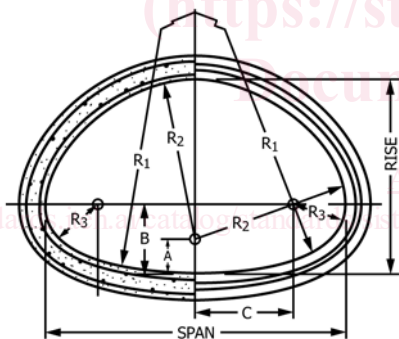

$$A = \text{Rise} - R_2$$

$$B = A + \sqrt{(R_2 - R_3)^2 - C^2}$$

$$C = \frac{\text{Span}}{2} - R_3$$

Approximate Equivalent Round Size, in.	Water Area, ft ²	Rise, in.	Span, in.	A, in.	B, in.	C, in.	R ₁ , in.	R ₂ , in.	R ₃ , in.
15	1.1	11	18	3/8	4 11/16	4 31/32	22 7/8	10 5/8	4 1/32
18	1.65	13 1/2	22	-1/4	6	5 9/4	27 1/2	13 3/4	5 1/4
21	2.2	15 1/2	26	3/4	6 1/4	7 3/4	35 1/2	14 3/4	5 1/4
24	2.8	18	28 1/2	3 7/16	5 29/32	9 21/32	40 11/16	14 9/16	4 19/32
30	4.4	22 1/2	36 1/4	3 3/4	7 11/16	12 3/32	51	18 3/4	6 1/32
36	6.4	26 5/8	43 3/4	4 1/8	8 9/16	15 1/2	62	22 1/2	6 3/8
42	8.8	31 5/16	51 1/8	5 1/16	10 1/16	18	73	26 1/4	7 9/16
48	11.4	36	58 1/2	6	11 19/32	20 1/2	84	30	8 3/4
54	14.3	40	65	6 5/8	13	22 11/16	92 1/2	33 3/8	9 13/16
60	17.7	45	73	7 1/2	14 11/16	25 9/32	105	37 1/2	11 7/32
72	25.6	54	88	9	17	31 7/16	126	45	12 9/16
84	34.6	62	102	10	18 21/32	37 1/32	162 1/2	52	13 31/32
90	44.5	72	115	13	23 13/16	38 7/32	183	59	19 9/32
96	51.7	77 1/4	122	15 1/4	24 11/32	40 15/16	218	62	20 1/16
108	66.0	87 1/8	138	17 1/8	26 27/32	46 5/8	269	70	22 3/8
120	81.8	96 7/8	154	18 7/8	29 7/32	53	301 3/8	78	24
132	99.1	106 1/2	168 3/4	20 7/8	32 15/16	57 1/2	329	85 5/8	26 7/8

FIG. 1 Cross-Sectional Shape of Arch Pipe