INTERNATIONAL STANDARD



3612

INTERNATIONAL ORGANIZATION FOR STANDARDIZATION • МЕЖДУНАРОДНАЯ ОРГАНИЗАЦИЯ ПО СТАНДАРТИЗАЦИИ • ORGANISATION INTERNATIONALE DE NORMALISATION

Tobacco and tobacco products — Cigarettes — Determination of rate of free combustion

Tabac et produits du tabac — Cigarettes — Détermination de la vitesse de combustion libre

First edition — 1977-10-15

ITeH STANDARD PREVIEW
(standards.iteh.ai)

[ISO 3612:1977](https://standards.iteh.ai/catalog/standards/sist/4defc75-5c69-4057-8f94-71019f19b54/iso-3612-1977)

<https://standards.iteh.ai/catalog/standards/sist/4defc75-5c69-4057-8f94-71019f19b54/iso-3612-1977>

UDC 663.97 : 543.874

Ref. No. ISO 3612-1977 (E)

Descriptors : tobacco, cigarettes, physical tests, roasting tests, measurement, burning rate.

Price based on 8 pages

FOREWORD

ISO (the International Organization for Standardization) is a worldwide federation of national standards institutes (ISO member bodies). The work of developing International Standards is carried out through ISO technical committees. Every member body interested in a subject for which a technical committee has been set up has the right to be represented on that committee. International organizations, governmental and non-governmental, in liaison with ISO, also take part in the work.

Draft International Standards adopted by the technical committees are circulated to the member bodies for approval before their acceptance as International Standards by the ISO Council.

International Standard ISO 3612 was developed by Technical Committee ISO/TC 126, *Tobacco and tobacco products*, and was circulated to the member bodies in June 1975.

(standards.iteh.ai)

It has been approved by the member bodies of the following countries :

Belgium	Iran	Switzerland
Brazil	Ireland	Thailand
Czechoslovakia	Netherlands	Turkey
France	Poland	United Kingdom
Germany	Romania	U.S.S.R.
Hungary	South Africa, Rep. of	Yugoslavia
India	Spain	

No member body expressed disapproval of the document.

Tobacco and tobacco products — Cigarettes — Determination of rate of free combustion

1 SCOPE AND FIELD OF APPLICATION

1.1 This International Standard specifies two methods for the determination of the rate of free combustion of cigarettes. Both methods yield the same result and both methods also enable the combustibility rate (3.3) to be determined.

In addition, the indirect method (see clause 8) enables the free combustion gradient (3.4) and the intrinsic combustibility (3.5) to be calculated, and has an advantage over the direct method (see clause 7) in being unaffected by irregularity in the linear progression of the burning zone.

1.2 Both methods are applicable to cigarettes and comparable cylindrical products (for example, products wrapped in reconstituted tobacco) that may be consumed by free combustion.

2 REFERENCES

ISO 3402, *Tobacco and tobacco products — Atmospheres for conditioning and testing.*

ISO . . . , *Tobacco and tobacco products — Cigarettes — Sampling.*¹⁾

3 DEFINITIONS

3.1 **free combustion** (of a cigarette) : Combustion without suction through the cigarette.

3.2 **rate of free combustion** (of a cigarette) : The average speed at which the leading edge of the combustion zone travels along the cigarette during free combustion. It is expressed in millimetres per minute.

3.3 **combustibility rate** (of a cigarette) : The rate at which the mass of tobacco contained in a cigarette is burnt during free combustion. It is expressed in milligrams per minute.

3.4 **free combustion gradient** (of a cigarette) : The rate of loss of mass of a cigarette during free combustion. It is expressed in milligrams per minute.

3.5 **intrinsic combustibility** (of a cigarette) : The ratio of the loss of mass during free combustion of a cigarette to its initial mass before combustion. It is expressed as a percentage.

4 PRINCIPLE

4.1 Direct method

Measurement of the time taken for a measured length of each of ten cigarettes to burn by free combustion and calculation of the rate of free combustion.

Determination on a further ten cigarettes of the mean mass of tobacco contained in the portion of the cigarettes burnt and calculation of the combustibility rate.

4.2 Indirect method

Measurement of the time taken for a measured length of ten cigarettes to burn by free combustion while the loss of mass is continuously recorded, the ash being collected continuously and weighed together with the other remains of the cigarettes. Calculation of the combustibility rate and the intrinsic combustibility from the graph of the free combustion rate.

5 SAMPLING

Carry out sampling by the method described in ISO Twenty cigarettes are required for the direct method (see clause 7) and 10 cigarettes for the indirect method (see clause 8).

6 CONDITIONING

Condition the sample in accordance with ISO 3402.

7 DIRECT METHOD

7.1 Apparatus

7.1.1 **Apparatus capable of measuring the time of free combustion of cigarettes** (figures 1 and 2 show suitable apparatus).

1) In preparation.

The apparatus may have more than one testing head. Each testing head shall be identical and shall have the following essential features :

- a) device for timing automatically free combustion over a measured length, normally $40 \pm 0,5$ mm (see note), of a cigarette; the device shall be activated by the burning through of two cotton threads of diameter $0,2 \pm 0,1$ mm;

NOTE — If necessary for shorter cigarettes, the length of $40 \pm 0,5$ mm may be reduced to $30 \pm 0,5$ mm.

- b) facility for adjusting the position of the cigarette so that there is 10 mm between the lighted end and the first cotton thread;
- c) a sliding cigarette holder with central needle on which the cigarette is held horizontally;
- d) arrangements whereby the cigarette is sheltered from draughts.

7.1.2 Lighter to light the test specimens.

7.1.3 **Smoke evacuation hood**, adjusted so that it does not alter the results by more than 1 % from those which would be obtained without any natural or artificial draught evacuation system (see details in figure 4).

7.1.4 Analytical balance.

7.2 Procedure

7.2.1 Preparation of test specimens

7.2.1.1 RATE OF FREE COMBUSTION

Using the conditioned sample, proceed as described in 7.2.2 without further preparation.

7.2.1.2 COMBUSTIBILITY RATE

Take two sets of 10 conditioned cigarettes. Use one set of 10 to determine the mean mass of tobacco contained in the portion of the cigarette to be burnt by free combustion. Using the other set, proceed as described in 7.2.2.

7.2.2 Free combustion

Test 10 cigarettes.

Adjust the apparatus (7.1.1) so that there will be at least 10 mm between the lighted end of each cigarette and the first cotton thread and so that the burning through of the cotton threads will time the free combustion over a distance of $40 \pm 0,5$ mm, if possible. If the cigarettes are too short to permit this, adjust the apparatus to time the free combustion over a distance of $30 \pm 0,5$ mm. Attach the cotton threads to the timing device [7.1.1 a)].

Light the cigarettes using the lighter (7.1.2). When the second cotton thread burns through and stops the timing device for each cigarette, note the time recorded for each cigarette.

8 INDIRECT METHOD

8.1 Apparatus (see schematic diagram in figure 3)

8.1.1 **Support with 10 spikes** at least 30 mm apart on which the test specimens are mounted horizontally. The support is placed on an ash-tray.

8.1.2 **Recording analytical balance**, capable of making a recording similar to that shown in figure 5. For example, a balance having the following characteristics will be suitable :

- a) range : 0 to 200 g;
- b) recording on cylinder
 - height : 150 mm (mass axis);
 - circumference : 240 mm (time axis);
- c) sensitivity : 1 mm/50 mg;
- d) speed
value normally adopted :
4 rev/h = 1 rev/15 min = 16 mm/min.

8.1.3 **Lighting device**, designed to light 10 test specimens simultaneously.

8.1.4 **Smoke evacuation hood**, adjusted so that it does not alter the results by more than 1 % from those which would be obtained without any natural or artificial draught evacuation system. (See details in figure 4.)

8.1.5 Analytical balance.

8.2 Procedure

8.2.1 Preparation of test specimens

Take 10 cigarettes from the laboratory sample and cut them to the required tobacco length L ; for example : $L = 50 \pm 0,5$ mm. Weigh the 10 test specimens and determine their mean mass to the nearest 1 mg.

NOTE — The length of the cigarettes being tested may be too short to provide test specimens 50 mm in length and in such cases shorter test specimens may be used.

8.2.2 Determination

Mount the test specimens horizontally on the support (8.1.1) of the recording analytical balance (8.1.2).

Start the paper drive of the recording balance. Light the 10 test specimens simultaneously with the lighting device (8.1.3).

Allow the combustion of the test specimens to proceed so that the mass of the products consumed is recorded permanently in the form of a graph. The ash is collected on the ash-tray (see 8.1.1).

If cigarette ends remain incompletely consumed when combustion ceases, burn them in order to reduce all the test specimens completely to ash.

8.2.3 Examination of the recording chart

Remove the recording chart from the cylinder. Extrapolate the linear part of the trace as far as the ordinates corresponding respectively to the initial mass (starting point) and the final mass (end point).

By extrapolation, measure the change in mass (the difference between the initial mass of the test specimens and the mass of their ash), and the time which has elapsed, t , both these values corresponding to the length L of the test specimens. (See figure 5 for the principle of analysis of a measurement.)

9 EXPRESSION OF RESULTS

9.1 Calculate the rate of free combustion, v , expressed in millimetres per minute, using the formula

$$v = \frac{L}{t}$$

where

L is the length, in millimetres, of the consumed portions of the test specimens;

t is the corresponding time, in minutes, of free combustion.

9.2 Calculate the combustibility rate, C , expressed in milligrams per minute, using the formula

$$C = \frac{m}{t}$$

where

m is the mass of tobacco, in milligrams, contained in the consumed portion of the cigarettes (as determined according to 7.2.1.2 or 8.2.1, as appropriate);

t is the time, in minutes, of free combustion for this portion.

9.3 Calculate the free combustion gradient, B , expressed in milligrams per minute, using the formula

$$B = \frac{\Delta m}{t}$$

where

Δm is the loss in mass, in milligrams, relating to one test specimen;

t is the corresponding time, in minutes, of free combustion.

9.4 Calculate the intrinsic combustibility, K , expressed as a percentage, using the formula

$$K = \frac{\Delta m}{m} \times 100$$

where

Δm is the mean loss in mass, in milligrams, of one test specimen;

m is the mean initial mass, in milligrams, of one test specimen.

10 TEST REPORT

The test report shall show the method used and the results obtained. It shall also mention any operating conditions not specified in this International Standard, or regarded as optional, as well as any circumstances which may have influenced the results.

The conditioning and test atmospheres shall be given in the test report.

If determined, the water content of the test sample shall also be given.

The test report shall include all information necessary for the complete identification of the sample.

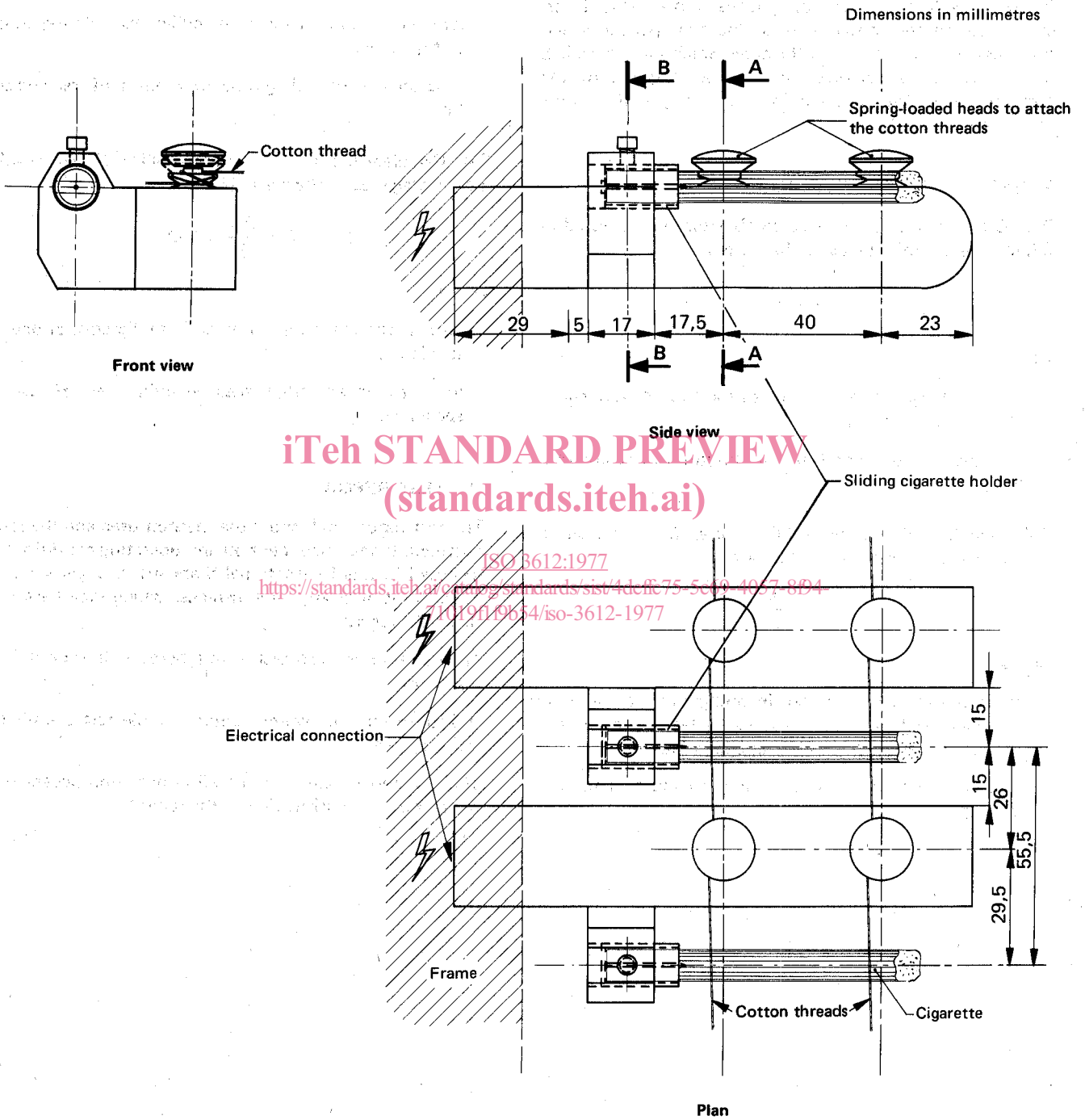
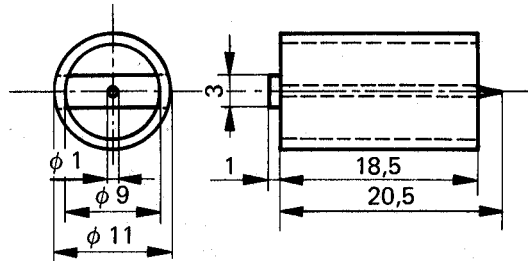

FIGURE 1 – Direct method – Schematic diagram of apparatus

Dimensions in millimetres



Details of cigarette holder

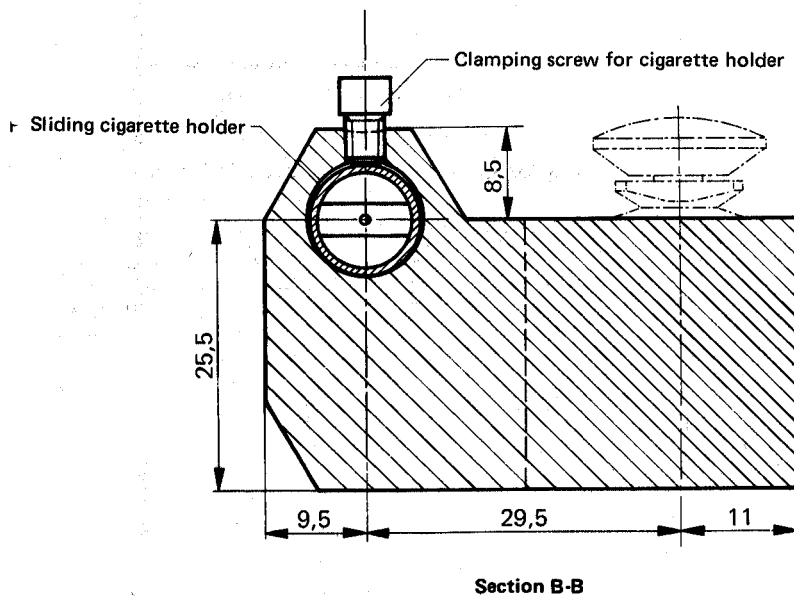
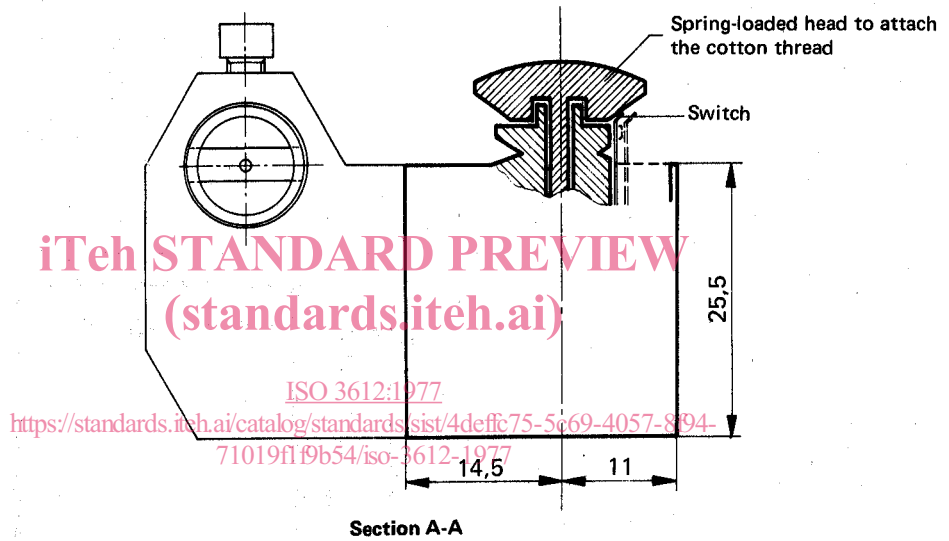

FIGURE 2 — Direct method — Details of cigarette holder

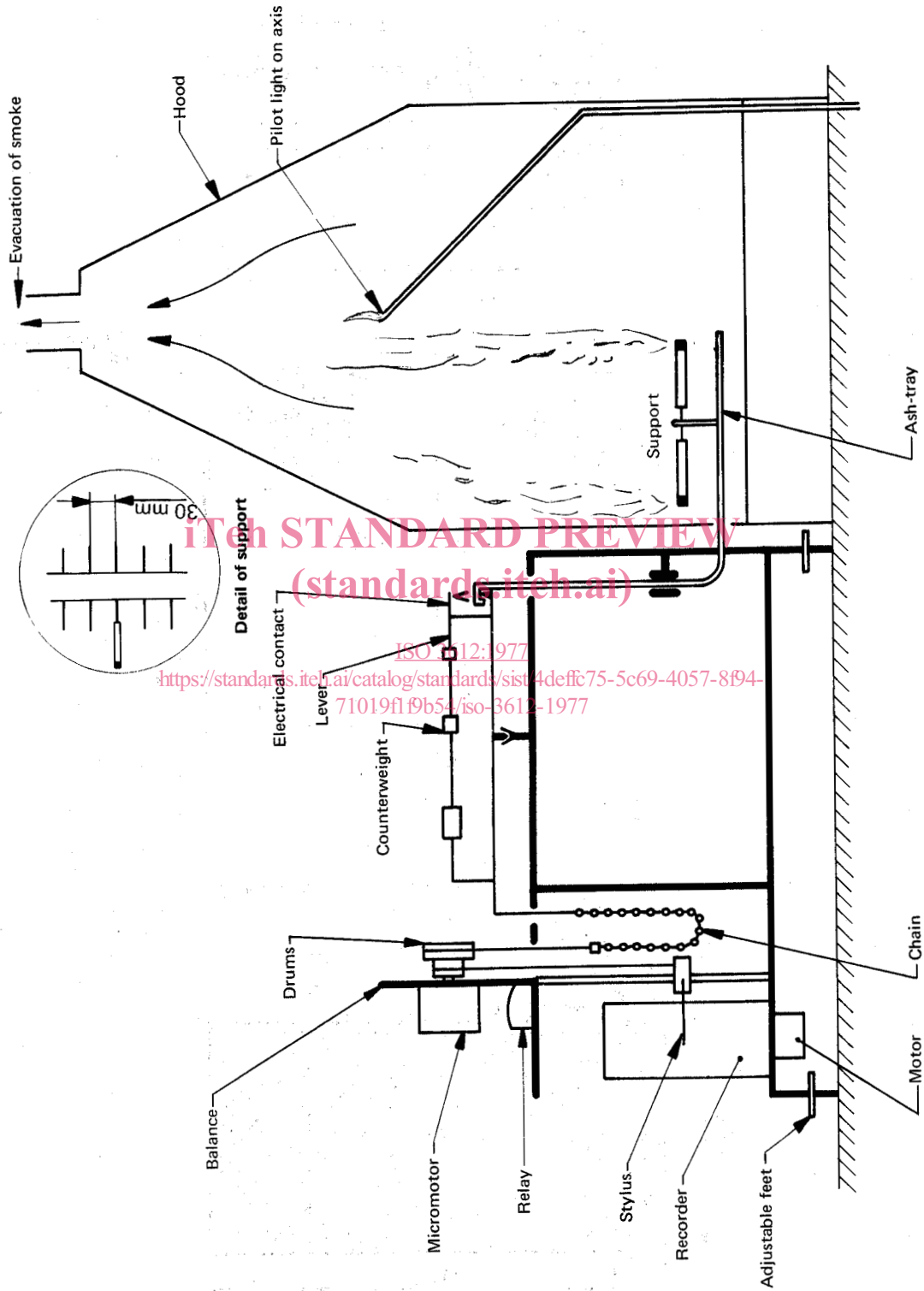
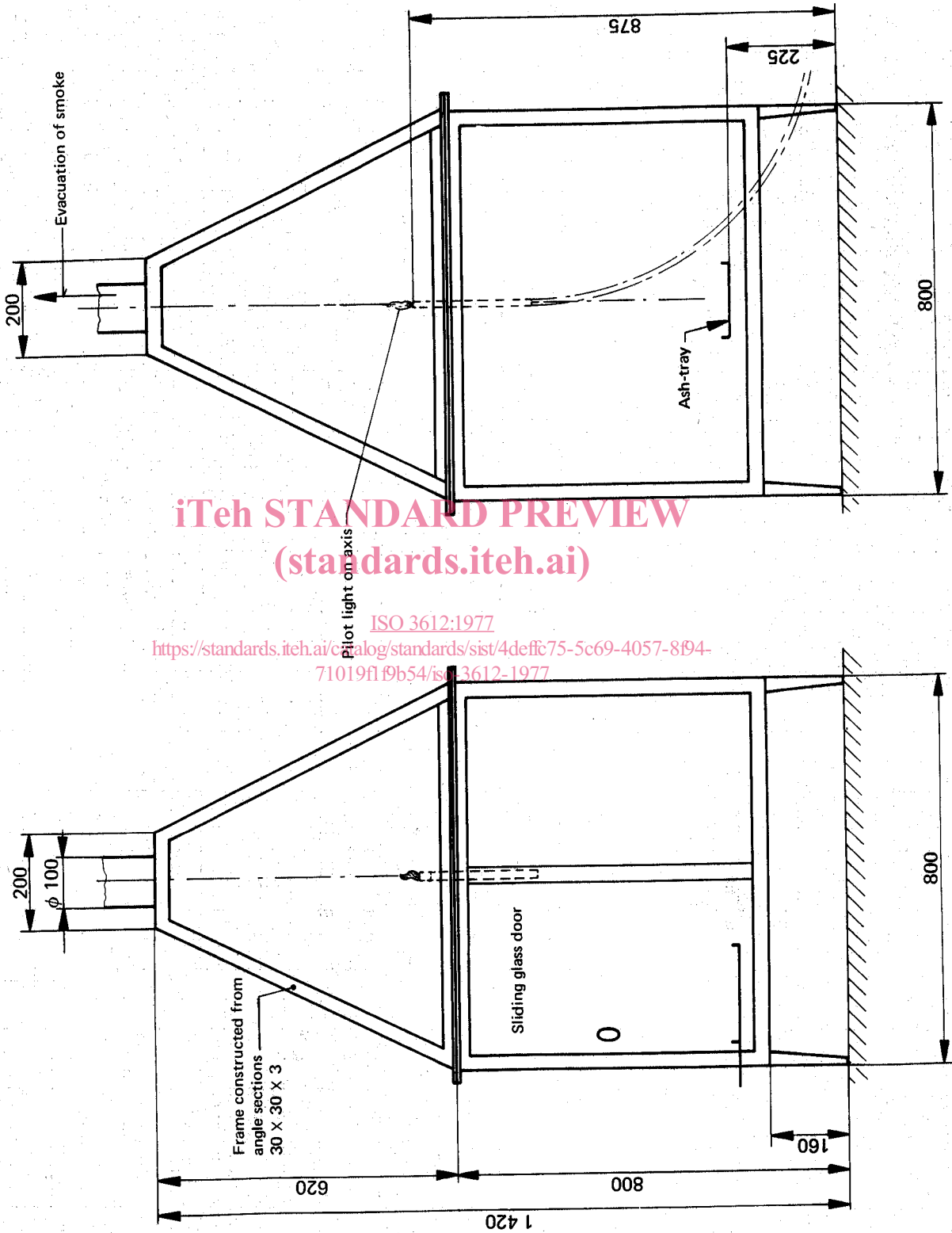

FIGURE 3 — Indirect method — Schematic diagram of apparatus

Dimensions in millimetres



iTeh STANDARD PREVIEW
(standards.iteh.ai)

ISO 3612:1977
<https://standards.iteh.ai/catalog/standards/sist/4deffc75-5c69-4057-8f94-71019f1f9b54/iso-3612-1977>

FIGURE 4 — Indirect method and direct method — Details of hood