



Designation: C1540 – 14

Standard Specification for Heavy Duty Shielded Couplings Joining Hubless Cast Iron Soil Pipe and Fittings¹

This standard is issued under the fixed designation C1540; the number immediately following the designation indicates the year of original adoption or, in the case of revision, the year of last revision. A number in parentheses indicates the year of last reapproval. A superscript epsilon (ϵ) indicates an editorial change since the last revision or reapproval.

1. Scope

1.1 This specification covers the evaluating of the performance of heavy duty shielded couplings to join hubless cast iron soil pipe and fittings.

1.2 Couplings covered by this standard shall have nominal dimensions as found in [Table 1](#) and [Fig. 1](#) of this standard.

1.3 The values stated in inch-pound units are to be regarded as standard. The values given in parentheses are mathematical conversions to SI units that are provided for information only and are not considered standard.

1.4 The following precautionary caveat pertains only to the test method portion, Section 7, of this specification. *This standard does not purport to address all of the safety concerns, if any, associated with its use. It is the responsibility of the user of this standard to establish appropriate safety and health practices and determine the applicability of regulatory limitations prior to use.*

2. Referenced Documents

2.1 *ASTM Standards*:²

[A240/A240M Specification for Chromium and Chromium-Nickel Stainless Steel Plate, Sheet, and Strip for Pressure Vessels and for General Applications](#)

[A493 Specification for Stainless Steel Wire and Wire Rods for Cold Heading and Cold Forging](#)

[A644 Terminology Relating to Iron Castings](#)

[A888 Specification for Hubless Cast Iron Soil Pipe and Fittings for Sanitary and Storm Drain, Waste, and Vent Piping Applications](#)

[C564 Specification for Rubber Gaskets for Cast Iron Soil Pipe and Fittings](#)

¹ This specification is under the jurisdiction of ASTM Committee A04 on Iron Castings and is the direct responsibility of Subcommittee A04.75 on Gaskets and Coupling for Plumbing and Sewer Piping.

Current edition approved Oct. 1, 2014. Published February 2015. Originally approved in 2002. Last previous edition approved in 2011 as C1540 – 11. DOI: 10.1520/C1540-14.

² For referenced ASTM standards, visit the ASTM website, www.astm.org, or contact ASTM Customer Service at service@astm.org. For *Annual Book of ASTM Standards* volume information, refer to the standard's Document Summary page on the ASTM website.

[D3677 Test Methods for Rubber—Identification by Infrared Spectrophotometry](#)

2.2 *CISPI Standards*:³

[CISPI-301 Specification for Hubless Cast Iron Soil Pipe and Fittings for Sanitary and Storm Drain, Waste and Vent Piping Applications](#)

[CISPI-310 Specification for couplings for use in Connection with Hubless Cast Iron Soil Pipe and Fittings for Sanitary and Storm Drain, Waste and Vent Piping Applications](#)

2.3 *Factory Mutual Standards*:⁴

[FM 1680 Approval Standard for Couplings Used in Hubless Cast Iron Systems for Drain, Waste or Vent, Sewer, Rainwater or Storm Drain Systems Above and Below Ground, Industrial/Commercial and Residential](#)

3. Terminology

3.1 Definitions of the following terms used in this specification are found in Terminology [A644](#).

3.2 *Definitions of Terms Specific to This Standard*:

3.2.1 *center stop, n*—an integral part of the gasket centered on the axial length of the gasket intended to limit the insertion depth of the pipe to be coupled.

3.2.2 *clamp assembly, n*—that portion of the coupling excluding the gasket.

3.2.3 *coupling, n*—the complete assembly.

3.2.4 *coupling manufacturer, n*—the entity that assembles the gasket with the clamp and shield assembly.

3.2.5 *fitting, n*—parts of a pipeline other than straight pipes, valves, or couplings.

3.2.6 *gasket, n*—the elastomeric portion of the coupling.

3.2.7 *gasket manufacturer, n*—the entity that molds the gaskets inserted into the couplings covered by this standard specification.

3.2.8 *heavy duty coupling, n*—a shielded coupling that has dimensions detailed in [Table 1](#) and [Fig. 1](#).

³ Available from Cast Iron Soil Pipe Institute (CISPI), 5959 Shallowford Rd., Suite 419, Chattanooga, TN 37421, <http://www.cispi.org>.

⁴ Available from FM Approvals, P.O. Box 9102, Norwood, MA 02062. <http://www.fmglobal.com>.

TABLE 1

Nominal Pipe Size	Nominal Coupling Width
1½ to 4 in. (38 to 100 mm)	3 in. (76 mm)
5 to 10 in. (127 to 254 mm)	4 in. (100 mm)
12 to 15 in. (305 to 381 mm)	5½ in. (140 mm)

Table 1 of that document. Typical dimensions shall be in accordance with Fig. 2 and Table 2.

4.2 Clamp assembly screws or bolts shall not have screw-driver slots.

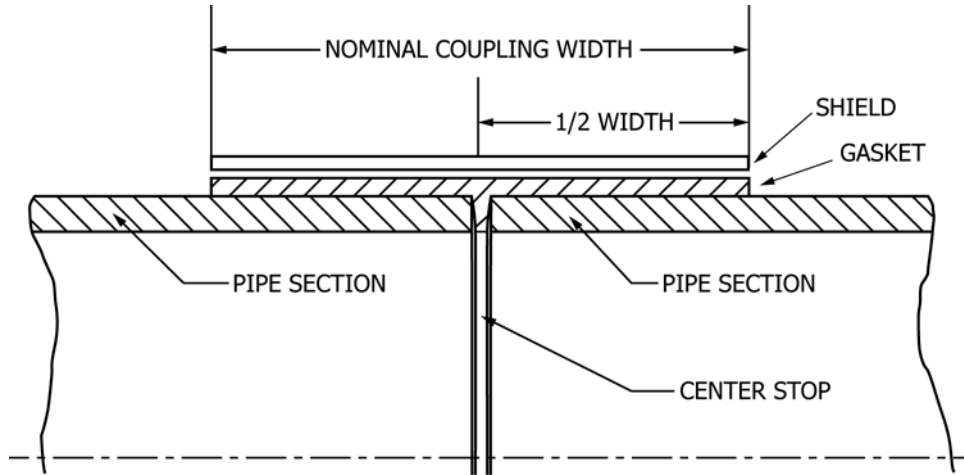

FIG. 1 Typical Center Stop Detail

3.2.9 *joint, n*—the point of assembly consisting of the coupling and the joined pipes or fittings, or both.

3.2.10 *shield, n*—an external metallic protective device designed to protect the sealing gasket from external elements that could cause failure of the sealing assembly.

4. Materials and Manufacture

4.1 Physical and chemical properties of gaskets shall comply with Specification C564 in accordance with Column “C” of

4.3 All stainless steel shall meet the physical requirements of Specification A240/A240M.

5. Elastomeric Gasket Requirements

5.1 The gasket shall be tested in accordance with Test Methods D3677 and be manufactured from a properly vulcanized virgin compound where the primary elastomer is polychloroprene (neoprene).

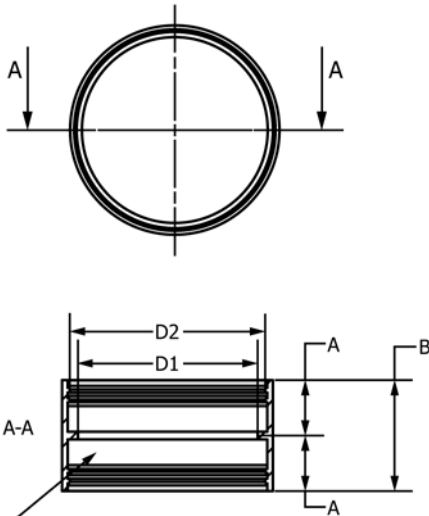

MARKINGS SHALL BE BETWEEN SEALING BEADS AND CENTER STOP. MARKINGS MAY BE ON BOTH SIDES OF CENTER STOP

	Dimensions									
	1 1/2 in.	2 in.	3 in.	4 in.	5 in.	6 in.	8 in.	10 in.	12 in.	15 in.
A	1.500	1.500	1.500	1.500	2.000	2.000	2.000	2.000	2.750	2.750
B	3.000	3.000	3.000	3.000	4.000	4.000	4.000	4.000	5.500	5.500
D1	1.531	1.968	2.968	3.968	4.968	5.968	7.968	9.975	12.000	15.200
D2	1.937	2.343	3.343	4.343	5.343	6.343	8.343	10.350	12.430	15.650

NOTE 1—The dimensions A and B found in the table are mandatory. Dimensions D1 and D2 found in the table are reference only for mold design. Sealing ring shape and dimensions are to manufacturer's design.

NOTE 2—Dimensional Tolerances to be RMA Class 3 (See Table 2).

FIG. 2 Rubber Gasket

TABLE 2 Dimensional Tolerances for Rubber—Standard Dimensional Tolerances RMA CLASS 3

Size, in.	Fixed, ±	Closure, ±
0 to 0.499	0.010	0.015
0.500 to 0.999	0.010	0.018
1.000 to 1.999	0.015	0.020
2.000 to 2.999	0.020	0.025
3.000 to 3.999	0.025	0.030
4.000 to 4.999	0.030	0.035
5.000 to 7.999	0.035	0.050

NOTE 1—8.000 and over—multiplied by 0.0050. These are commercial tolerances. All diametric dimensions shall have a tolerance of ± 1 %.

5.2 The elastomeric gasket shall consist of one piece construction conforming to the physical requirements of Specification C564. The gaskets shall be tested by the gasket manufacturer for compliance to Specification C564 a minimum of 24 hours after production, but not longer than 72 hours after time of production. These tests shall include hardness, elongation and tensile strength, tear strength and compression set. Heat, aging, water absorption, ozone resistance and oil immersion tests shall be conducted annually or when a formulation changes, or a supplier changes, whichever occurs first.

5.2.1 The elastomeric gasket shall have an inside center stop that does not create an enlargement chamber or recess with a ledge, shoulder, or reduction of pipe area or offer an obstruction to flow.

5.2.2 The elastomeric gasket shall be free of defects that affect the use and serviceability.

6. Clamp Assembly Requirements

6.1 The clamp assembly shall be made of material conforming to the requirements as outlined in Sections 4 and 6, Table 3, and Fig. 3.

TABLE 3 Material Specifications

Band	Type 301 AISI Stainless Steel— Minimum Tensile 140 000 psi for 1 1/2 to 15 in.; Type 304 AISI Stainless Steel is permitted.
	Type 304 AISI Stainless Steel— Minimum Tensile 140 000 psi
Eyelets/Rivets	Type 300 grade AISI Stainless Steel
Screw Housing	Type 301 AISI Stainless Steel for 1 1/2 to 15 in.; Type 304 AISI Stainless Steel is permitted.
Screw	Type 305 AISI or Type 304L, or both, Annealed Stainless Steel— Manufacturer's shall identify recommended installation torques for their couplings either on the couplings or within installation instructions.
Shield	Type 301 AISI or Type 304, or both, AISI Stainless Steel (Annealed and Pickled Not Acceptable)
	Hardness—Rockwell B-100 (Vickers 240) in accordance with A240/A240M Max (Max Burr Height Not to Exceed 25 % of Thickness)
	Thickness—0.0065 in. Min

6.1.1 All metallic parts shall be of 300 series stainless steel and shall conform to the requirements of Specification A240/A240M. All metallic parts made from round stock shall be of 300 series stainless steel and shall conform to the requirements of Specification A493 (excluding copper bearing alloys).

6.1.2 Clamp assemblies shall be tested to withstand no less than 125 % of the manufacturers stated installation torque without visible signs of failure. The clamp assembly shall be tested over a steel mandrel of the appropriate diameter and torqued as required. These tests shall be performed on randomly selected samples during the course of production as needed, but not less than one clamp per shift per size during clamp assembly production.

7. Couplings Requirements and Test Methods

7.1 Assemble each coupling to be tested according to the manufacturer's instructions between two sections of randomly selected hubless cast iron soil pipe meeting the requirements of CISPI 301 or Specification A888 and conduct deflection and

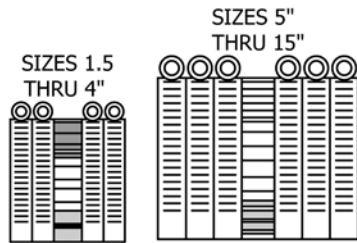

SHIELD AND CLAMP ASSEMBLY

MANUFACTURERS MAY HAVE DIFFERENT NUMBER OF CLAMPS BASED ON THEIR COUPLING DESIGNS

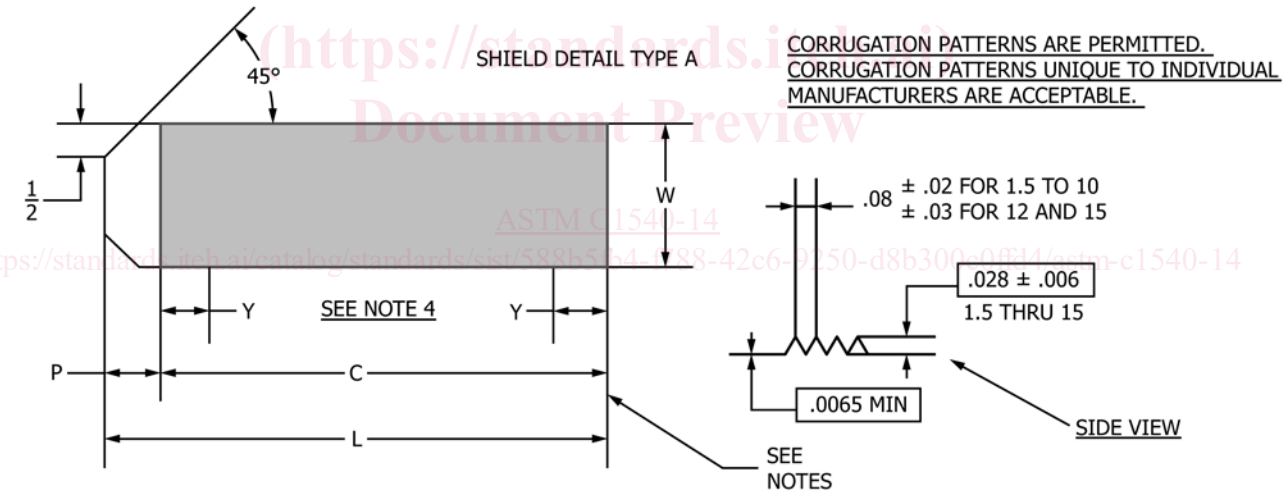
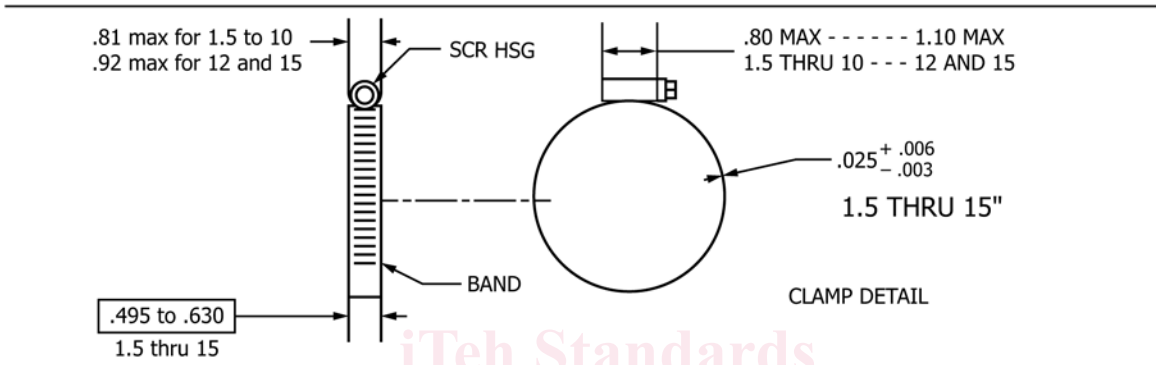

1. SINGLE CORRUGATIONS ARE SHOWN IN DRAWING SIDE VIEW. THE "P" DIMENSION MIGHT NOT APPLY TO ALL COUPLING DESIGNS.
2. THE "P" DIMENSION (IF APPLICABLE), IS PERMITTED ON EITHER END OF THE CORRUGATED SHIELD.
3. MEASURE CORRUGATION MATERIAL THICKNESS AND FORMED THICKNESS WITH CALIPERS OR DISC MICROMETER
4. ON CORRUGATED SHIELDS, TAPERING OF CORRUGATIONS IS ALLOWED AT EITHER END TO IMPROVE FUNCTIONALITY.

FIG. 3 Shield and Clamp Assembly.

shear tests. In addition, unrestrained hydrostatic tests shall be performed as detailed in 7.2. The deflection and shear tests

shall be performed on each size and type coupling utilizing first article approval as required not to exceed 120 days. The