



Designation: D7136/D7136M – 15

Standard Test Method for Measuring the Damage Resistance of a Fiber-Reinforced Polymer Matrix Composite to a Drop-Weight Impact Event¹

This standard is issued under the fixed designation D7136/D7136M; the number immediately following the designation indicates the year of original adoption or, in the case of revision, the year of last revision. A number in parentheses indicates the year of last reapproval. A superscript epsilon (ϵ) indicates an editorial change since the last revision or reapproval.

1. Scope

1.1 This test method determines the damage resistance of multidirectional polymer matrix composite laminated plates subjected to a drop-weight impact event. The composite material forms are limited to continuous-fiber reinforced polymer matrix composites, with the range of acceptable test laminates and thicknesses defined in 8.2.

1.1.1 Instructions for modifying these procedures to determine damage resistance properties of sandwich constructions are provided in Practice [D7766/D7766M](#).

1.2 A flat, rectangular composite plate is subjected to an out-of-plane, concentrated impact using a drop-weight device with a hemispherical impactor. The potential energy of the drop-weight, as defined by the mass and drop height of the impactor, is specified prior to test. Equipment and procedures are provided for optional measurement of contact force and velocity during the impact event. The damage resistance is quantified in terms of the resulting size and type of damage in the specimen.

1.3 The test method may be used to screen materials for damage resistance, or to inflict damage into a specimen for subsequent damage tolerance testing. When the impacted plate is tested in accordance with Test Method [D7137/D7137M](#), the overall test sequence is commonly referred to as the Compression After Impact (CAI) method. Quasi-static indentation per Test Method [D6264/D6264M](#) may be used as an alternate method of creating damage from an out-of-plane force and measuring damage resistance properties.

1.4 The damage resistance properties generated by this test method are highly dependent upon several factors, which include specimen geometry, layup, impactor geometry, impactor mass, impact force, impact energy, and boundary conditions. Thus, results are generally not scalable to other configurations, and are particular to the combination of geometric and physical conditions tested.

1.5 The values stated in either SI units or inch-pound units are to be regarded separately as standard. The values stated in each system may not be exact equivalents; therefore, each system shall be used independently of the other. Combining values from the two systems may result in non-conformance with the standard.

1.5.1 Within the text the inch-pound units are shown in brackets.

1.6 *This standard does not purport to address all of the safety concerns, if any, associated with its use. It is the responsibility of the user of this standard to establish appropriate safety and health practices and determine the applicability of regulatory limitations prior to use.*

2. Referenced Documents

2.1 *ASTM Standards:*²

[D792 Test Methods for Density and Specific Gravity \(Relative Density\) of Plastics by Displacement](#)

[D883 Terminology Relating to Plastics](#)

[D3171 Test Methods for Constituent Content of Composite Materials](#)

[D3763 Test Method for High Speed Puncture Properties of Plastics Using Load and Displacement Sensors](#)

[D3878 Terminology for Composite Materials](#)

[D5229/D5229M Test Method for Moisture Absorption Properties and Equilibrium Conditioning of Polymer Matrix Composite Materials](#)

[D5687/D5687M Guide for Preparation of Flat Composite Panels with Processing Guidelines for Specimen Preparation](#)

[D6264/D6264M Test Method for Measuring the Damage Resistance of a Fiber-Reinforced Polymer-Matrix Composite to a Concentrated Quasi-Static Indentation Force](#)

[D7137/D7137M Test Method for Compressive Residual Strength Properties of Damaged Polymer Matrix Composite Plates](#)

[D7766/D7766M Practice for Damage Resistance Testing of](#)

¹ This test method is under the jurisdiction of ASTM Committee [D30](#) on Composite Materials and is the direct responsibility of Subcommittee [D30.05](#) on Structural Test Methods.

Current edition approved March 15, 2015. Published March 2015. Originally approved in 2005. Last previous edition approved in 2012 as [D7136/D7136M - 12](#). DOI: 10.1520/D7136_D7136M-15.

² For referenced ASTM standards, visit the ASTM website, www.astm.org, or contact ASTM Customer Service at service@astm.org. For *Annual Book of ASTM Standards* volume information, refer to the standard's Document Summary page on the ASTM website.

Sandwich Constructions

- [E4 Practices for Force Verification of Testing Machines](#)
- [E6 Terminology Relating to Methods of Mechanical Testing](#)
- [E18 Test Methods for Rockwell Hardness of Metallic Materials](#)
- [E122 Practice for Calculating Sample Size to Estimate, With Specified Precision, the Average for a Characteristic of a Lot or Process](#)
- [E177 Practice for Use of the Terms Precision and Bias in ASTM Test Methods](#)
- [E456 Terminology Relating to Quality and Statistics](#)
- [E1309 Guide for Identification of Fiber-Reinforced Polymer-Matrix Composite Materials in Databases](#)
- [E1434 Guide for Recording Mechanical Test Data of Fiber-Reinforced Composite Materials in Databases](#)
- [E2533 Guide for Nondestructive Testing of Polymer Matrix Composites Used in Aerospace Applications](#)

2.2 *Military Standards:*

- [CMH-17-3G Composite Materials Handbook, Volume 3—Polymer Matrix Composites Materials Usage, Design and Analysis³](#)
- [MIL-HDBK-728/1 Nondestructive Testing⁴](#)
- [MIL-HDBK-731A Nondestructive Testing Methods of Composite Materials—Thermography⁴](#)
- [MIL-HDBK-732A Nondestructive Testing Methods of Composite Materials—Acoustic Emission⁴](#)
- [MIL-HDBK-733A Nondestructive Testing Methods of Composite Materials—Radiography⁴](#)
- [MIL-HDBK-787A Nondestructive Testing Methods of Composite Materials—Ultrasonics⁴](#)
- [NASA Reference Publication 1092 Standard Tests for Toughened Resin Composites, Revised Edition, July 1983⁵](#)

3. Terminology

3.1 *Definitions*—Terminology [D3878](#) defines terms relating to composite materials. Terminology [D883](#) defines terms relating to plastics. Terminology [E6](#) defines terms relating to mechanical testing. Terminology [E456](#) and Practice [E177](#) define terms relating to statistics. In the event of a conflict between terms, Terminology [D3878](#) shall have precedence over the other standards.

3.2 *Definitions of Terms Specific to This Standard:*

3.2.1 If the term represents a physical quantity, its analytical dimensions are stated immediately following the term (or letter symbol) in fundamental dimension form, using the following ASTM standard symbology for fundamental dimensions, shown within square brackets: $[M]$ for mass, $[L]$ for length, $[T]$ for time, $[\theta]$ for thermodynamic temperature, and $[nd]$ for non-dimensional quantities. Use of these symbols is restricted

³ Available from SAE International (SAE), 400 Commonwealth Dr., Warrendale, PA 15096-0001, <http://www.sae.org>.

⁴ Available from U.S. Army Materials Technology Laboratory, Watertown, MA 02471.

⁵ Available from National Aeronautics and Space Administration (NASA)-Langley Research Center, Hampton, VA 23681-2199.

to analytical dimensions when used with square brackets, as the symbols may have other definitions when used without the brackets.

3.2.2 *dent depth, d $[L]$, n* —residual depth of the depression formed by an impactor after the impact event. The dent depth shall be defined as the maximum distance in a direction normal to the face of the specimen from the lowest point in the dent to the plane of the impacted surface that is undisturbed by the dent.

3.2.3 *nominal value, n* —a value, existing in name only, assigned to a measurable property for the purpose of convenient designation. Tolerances may be applied to a nominal value to define an acceptable range for the property.

3.2.4 *principal material coordinate system, n* —a coordinate system with axes that are normal to the planes of symmetry inherent to a material.

3.2.4.1 *Discussion*—Common usage, at least for Cartesian axes (123 , xyz , and so forth), generally assigns the coordinate system axes to the normal directions of planes of symmetry in order that the highest property value in a normal direction (for elastic properties, the axis of greatest stiffness) would be 1 or x , and the lowest (if applicable) would be 3 or z . Anisotropic materials do not have a principal material coordinate system due to the total lack of symmetry, while, for isotropic materials, any coordinate system is a principal material coordinate system. In laminated composites, the principal material coordinate system has meaning only with respect to an individual orthotropic lamina. The related term for laminated composites is “reference coordinate system.”

3.2.5 *recorded contact force, F $[MLT^{-2}]$, n* —the force exerted by the impactor on the specimen during the impact event, as recorded by a force indicator.

3.2.6 *reference coordinate system, n* —a coordinate system for laminated composites used to define ply orientations. One of the reference coordinate system axes (normally the Cartesian x -axis) is designated the reference axis, assigned a position, and the ply principal axis of each ply in the laminate is referenced relative to the reference axis to define the ply orientation for that ply.

3.2.7 *striker tip, n* —the portion or component of the impactor which comes into contact with the test specimen first during the impact event.

3.3 *Symbols:*

A = cross-sectional area of a specimen

C_E = specified ratio of impact energy to specimen thickness

CV = coefficient of variation statistic of a sample population for a given property (in percent)

D = damage diameter (see [Fig. 11](#))

d = dent depth

E = potential energy of impactor prior to drop

E_1 = absorbed energy at the time at which force versus time curve has a discontinuity in force or slope

E_a = energy absorbed by the specimen during the impact event

E_i = actual impact energy (incident kinetic energy)

E_{max} = absorbed energy at the time of maximum recorded contact force

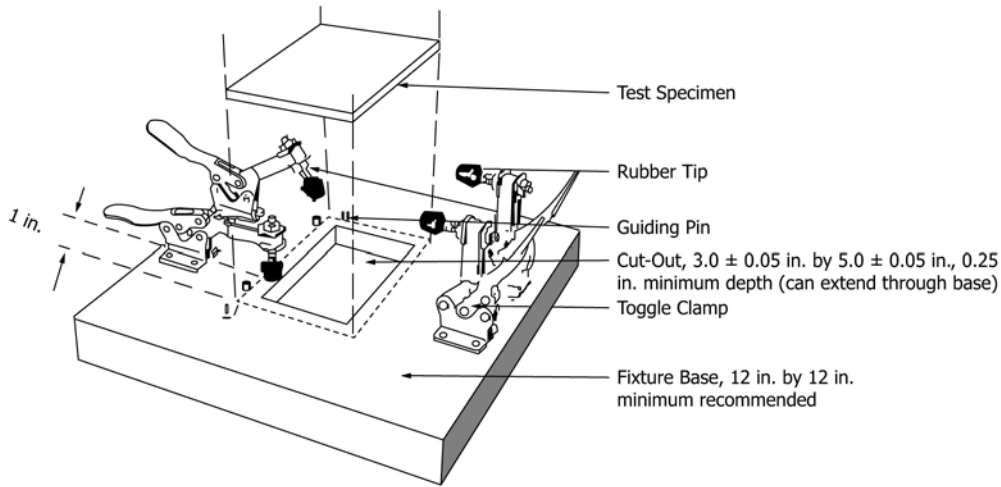

NOTE 1—Clamp tip centered 0.25 in. from edge of cut-out.

FIG. 1 Impact Support Fixture (Inch-Pound Version)

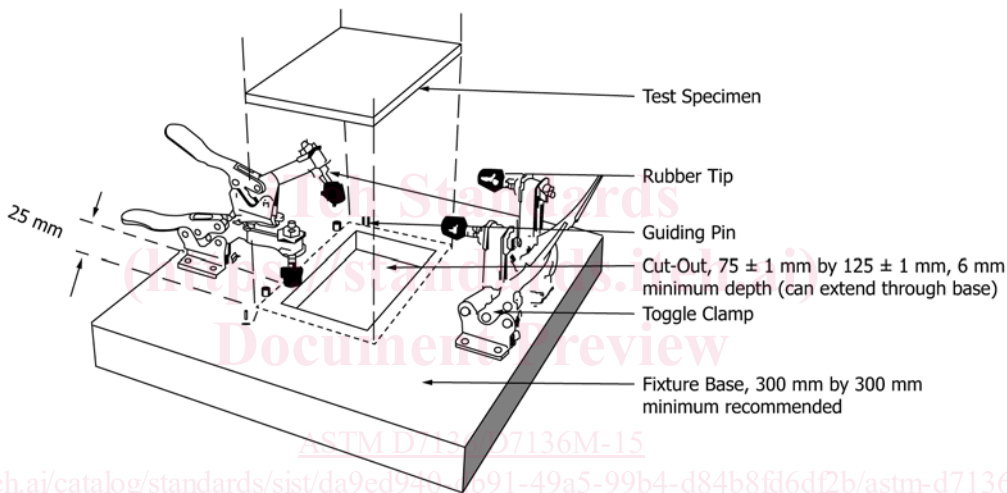

NOTE 1—Clamp tip centered 6 mm from edge of cut-out.

FIG. 2 Impact Support Fixture (SI Version)

F = recorded contact force
 F_1 = recorded contact force at which the force versus time curve has a discontinuity in force or slope
 F_{max} = maximum recorded contact force
 g = acceleration due to gravity
 h = specimen thickness
 H = impactor drop height
 l = specimen length
 m = impactor mass
 m_d = impactor mass for drop height calculation
 m_{dlbm} = impactor mass in standard gravity for drop height calculation
 n = number of specimens per sample population
 N = number of plies in laminate under test
 S_{n-1} = standard deviation statistic of a sample population for a given property
 t = time during impactor drop and impact event
 t_i = time of initial contact
 t_T = contact duration (total duration of the impact event)
 w = specimen width

v = impactor velocity
 v_i = impactor velocity at time of initial contact, t_i
 W_{12} = distance between leading edges of the two flag prongs on velocity indicator
 x_i = test result for an individual specimen from the sample population for a given property
 \bar{x} = mean or average (estimate of mean) of a sample population for a given property
 δ = impactor displacement

4. Summary of Test Method

4.1 A drop-weight impact test is performed using a balanced, symmetric laminated plate. Damage is imparted through out-of-plane, concentrated impact (perpendicular to the plane of the laminated plate) using a drop weight with a hemispherical striker tip. The damage resistance is quantified in terms of the resulting size and type of damage in the specimen. The damage response is a function of the test

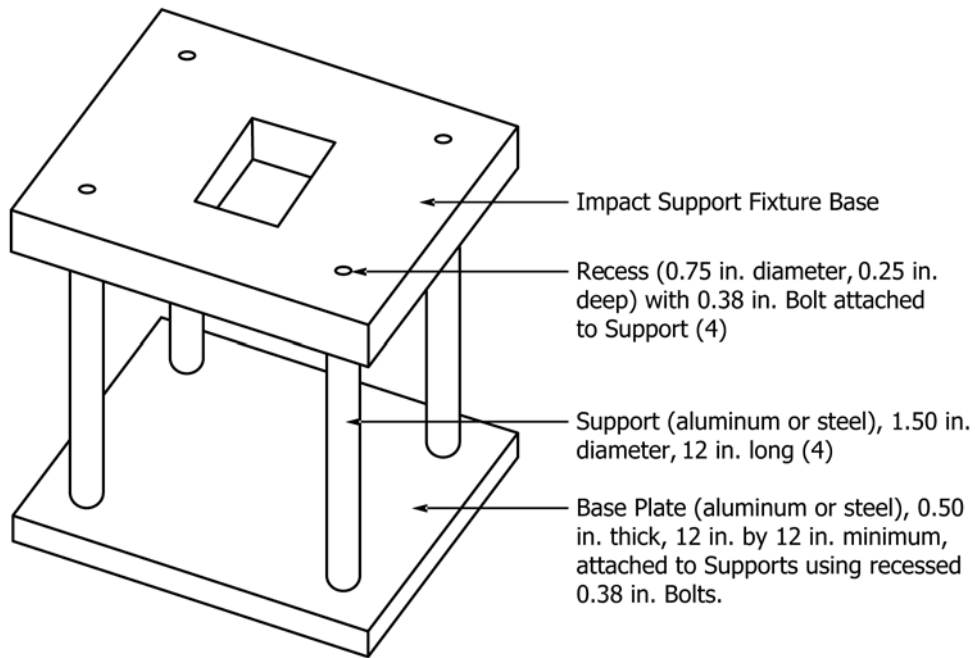

FIG. 3 Representative Rigid Base (Inch-Pound Version)

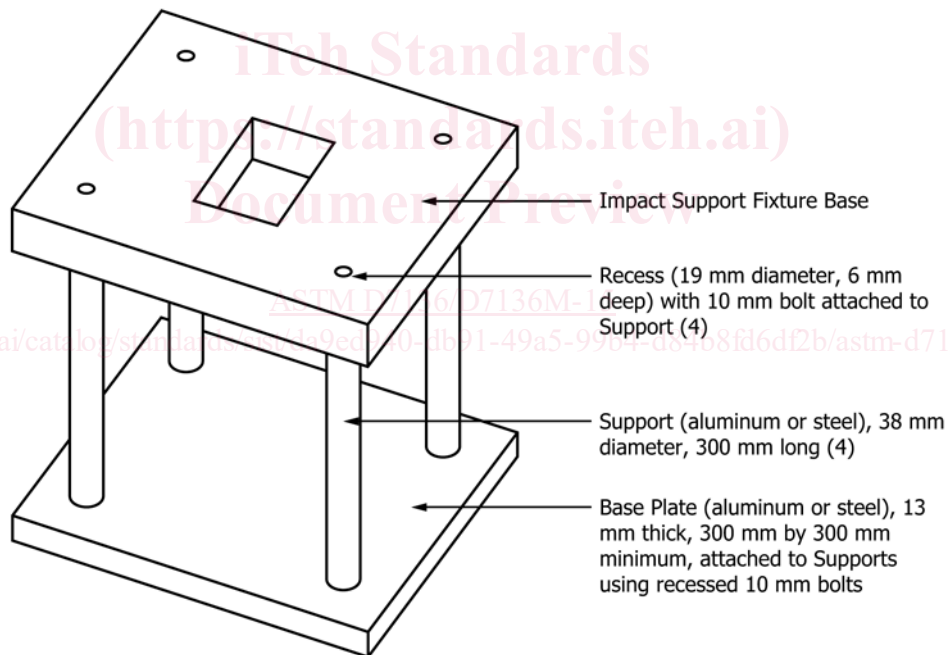

FIG. 4 Representative Rigid Base (SI Version)

configuration; comparisons cannot be made between materials unless identical test configurations, test conditions, and so forth are used.

4.2 Optional procedures for recording impact velocity and applied contact force versus time history data are provided.

4.3 Preferred damage states resulting from the impact are located in the center of the plate, sufficiently far from the plate edges such that the local states of stress at the edges and at the impact location do not interact during the damage formation event.

5. Significance and Use

5.1 Susceptibility to damage from concentrated out-of-plane impact forces is one of the major design concerns of many structures made of advanced composite laminates. Knowledge of the damage resistance properties of a laminated composite plate is useful for product development and material selection.

5.2 Drop-weight impact testing can serve the following purposes:

5.2.1 To establish quantitatively the effects of stacking sequence, fiber surface treatment, variations in fiber volume

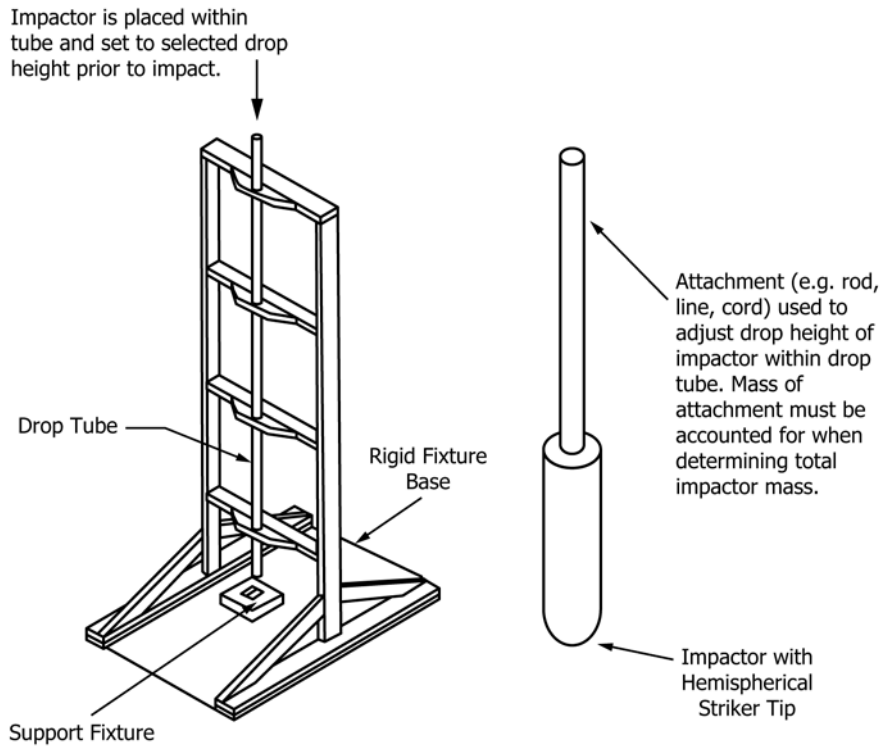

FIG. 5 Impact Device with Cylindrical Tube Impactor Guide Mechanism

ITeH Standards
 (https://standards.iteh.ai)
 Document Preview

ASTM D7136/D7136M-15

https://standards.iteh.ai/catalog/standards/sist/da9ed940-41b9-4015-99b4-d84b8fd6df2b/astm-d7136-d7136m-15

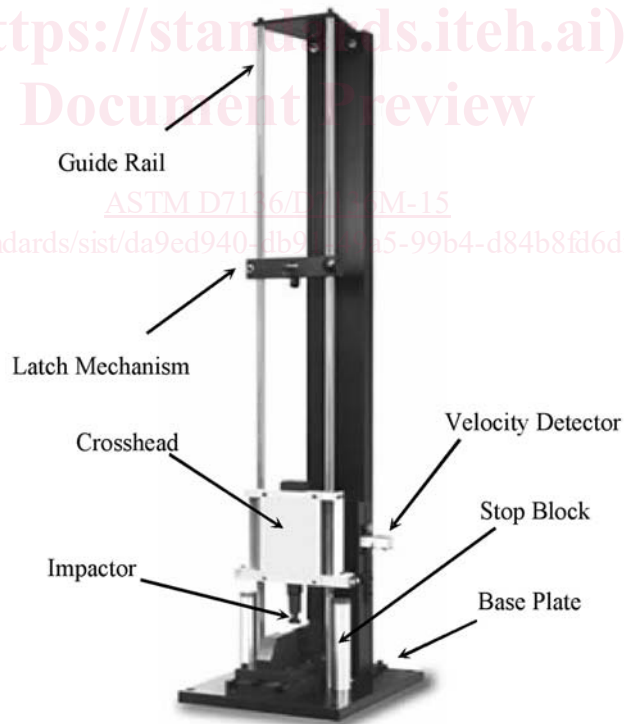

FIG. 6 Impact Device with Double Column Impactor Guide Mechanism

fraction, and processing and environmental variables on the damage resistance of a particular composite laminate to a concentrated drop-weight impact force or energy.

5.2.2 To compare quantitatively the relative values of the damage resistance parameters for composite materials with different constituents. The damage response parameters can

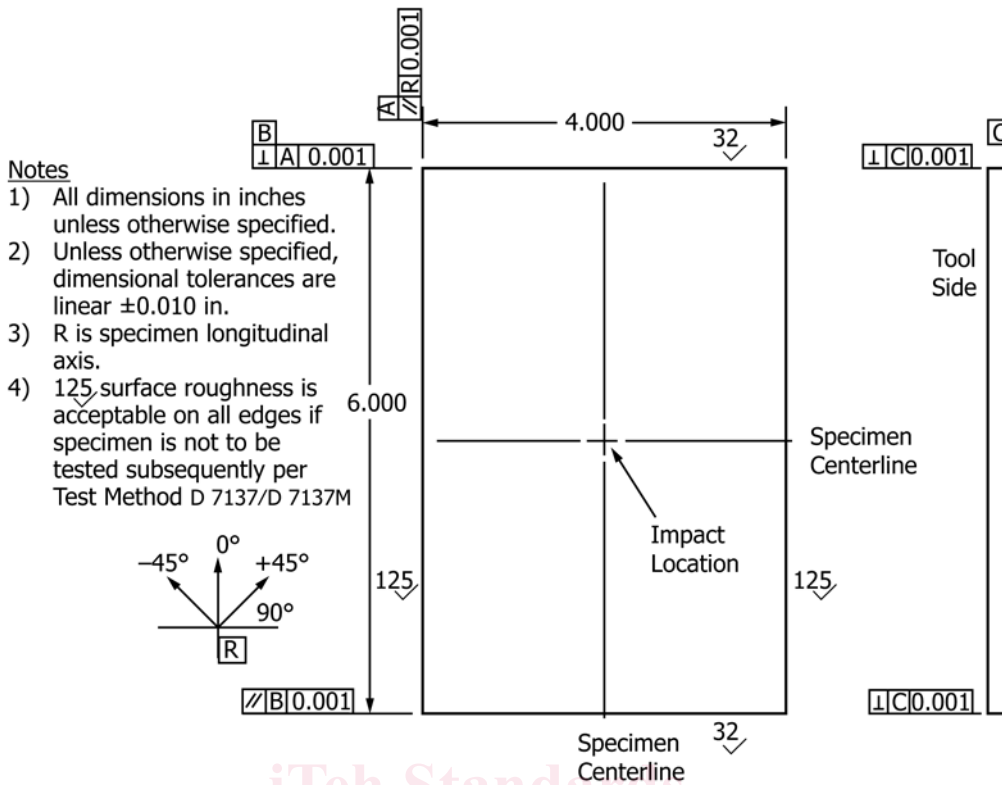

FIG. 7 Drop-Weight Impact Test Specimen (Inch-Pound Version)

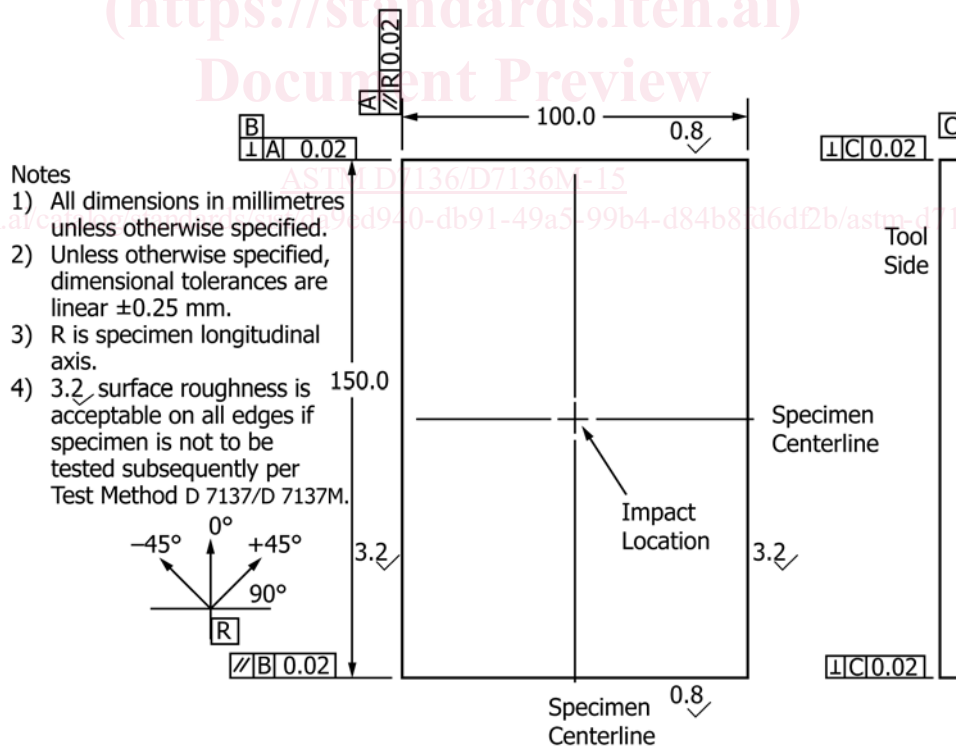

FIG. 8 Drop-Weight Impact Test Specimen (SI Version)

include dent depth, damage dimensions, and through-thickness locations, F_1 , F_{max} , E_1 and E_{max} , as well as the force versus time curve.

5.2.3 To impart damage in a specimen for subsequent damage tolerance tests, such as Test Method **D7137/D7137M**.