



Designation: **D7430—14 D7430 – 15**

## Standard Practice for Mechanical Sampling of Coal<sup>1</sup>

This standard is issued under the fixed designation D7430; the number immediately following the designation indicates the year of original adoption or, in the case of revision, the year of last revision. A number in parentheses indicates the year of last reapproval. A superscript epsilon ( $\epsilon$ ) indicates an editorial change since the last revision or reapproval.

### INTRODUCTION

Analysis data obtained from coal samples are used in establishing price, controlling mine and cleaning plant operations, allocating production costs, and determining plant or component efficiency. The task of obtaining a sample of reasonable weight/mass to represent an entire lot presents a number of problems and emphasizes the necessity for using standard sampling procedures.

Coal is one of the most difficult of materials to sample, varying in composition from noncombustible particles to those which can be burned completely, with all gradations in between. The task is further complicated by the use of the analytical results, the sampling equipment available, the quantity to be represented by the sample, and the degree of precision required.

This practice gives the overall requirements for the collection and within-system preparation of coal samples through the use of mechanical sampling systems utilizing falling stream, cross belt and auger designs. This practice also gives the overall requirements for the bias testing and quality management of mechanical coal sampling systems. The wide varieties of coal-handling facilities preclude the publication of detailed procedures for every sampling situation. The proper collection of the sample involves an understanding and consideration of the physical character of the coal, the number and weight/mass of increments, and the overall precision required.

### 1. Scope

1.1 This practice is divided into 4 parts. These 4 parts represent the previous standards **D7256/D7256M**, **D4916**, **D4702**, and **D6518**. These 4 standards are the 4 that govern the mechanical sampling of coal and have been combined into one document for the ease of reference of the users of these standards.

#### Part A

1.2 *Part A—Mechanical Collection and Within-System Preparation of a Gross Sample of Coal from Moving Streams*—Covers procedures for the mechanical collection of a sample under Classification I-B-1 and I-B-2 (Practice **D2234/D2234M**) and the within-system preparation (reduction and division) of gross samples utilizing various components of the mechanical sampling system.

1.2.1 Part A describes mechanical sampling procedures for coals (1) by size and condition of preparation (for example, mechanically cleaned coal or raw coal), and (2) by sampling characteristics.

1.2.2 The values stated in either SI units or inch-pound units are to be regarded separately as standard. The values stated in each system may not be exact equivalents; therefore, each system shall be used independently of the other. Combining values from the two systems may result in non-conformance with the standard.

#### Part B

1.3 *Part B—Mechanical Auger Sampling*—Describes procedures for the collection of an increment, partial sample, or gross sample of material using mechanical augers. Reduction and division of the material by mechanical equipment at the auger is also covered. Further manual or mechanical reduction or division of the material elsewhere shall be performed in accordance with Practice **D2013**.

1.3.1 The values stated in SI units are to be regarded as standard. No other units of measurement are included in this standard.

<sup>1</sup> This practice is under the jurisdiction of ASTM Committee **D05** on Coal and Coke and is the direct responsibility of Subcommittee **D05.23** on Sampling. Current edition approved ~~May 15, 2014~~ Feb. 1, 2015. Published ~~May 2014~~ April 2015. Originally approved in 2008. Last previous edition approved ~~2013~~ 2014 as **D7430-13-14**. DOI: ~~10.1520/D7430-14~~ 10.1520/D7430-15.

### Part C

1.4 *Part C—Quality Management of Mechanical Coal Sampling Systems*—Is applicable to the quality management of cross-belt, falling stream, and auger sampling systems.

1.4.1 Spacing of increments pertains to the kind of interval between increments. Intervals can be defined in quantitative terms, such as units of time or mass, or in terms of position over the lot.

1.4.2 *Spacing of Increments for Cross-Belt and Falling Stream Samplers*—Cross-belt and falling stream type mechanical sampling systems take increments based on time, either at fixed time intervals or at random times during a fixed time strata. Some falling stream samplers can take increments based on equal mass of coal sampled as determined by scales. The sections of this practice that pertain to cross-belt and falling stream samplers describe procedures for only time-based sampling systems. This time-based inspection guideline will satisfy most criteria for mass-based or combination mass-based and time-based sampling systems. If there are items that are not covered, the inspector should refer to the manufacturer’s literature.

1.4.3 *Spacing of Increments for Auger Sampling*—The spacing of increments collected by auger sampling systems is defined in terms of position over the lot.

1.4.4 It is essential that the inspector have the documentation listed in Section 2 of this practice when conducting an inspection.

1.4.5 The values stated in SI units are to be regarded as standard. No other units of measurement are included in this standard.

### Part D

1.5 *Part D—Bias Testing of a Mechanical Coal Sampling System*—Presents sample collection and statistical evaluation procedures for testing mechanical sampling systems (including auger systems), subsystems, and individual system components for bias. It is the responsibility of the user of this practice to select the appropriate procedure for a specific sampling situation.

1.5.1 Part D does not purport to define an absolute bias. Bias defined by this practice is the difference between the population mean of the mechanical sampler test results and the accepted reference value.

1.5.2 The values stated in SI units are to be regarded as standard. No other units of measurement are included in this standard.

1.6 *This standard does not purport to address all of the safety concerns, if any, associated with its use. It is the responsibility of the user of this standard to establish appropriate safety and health practices and determine the applicability of regulatory limitations prior to use.* For a specific hazard statement, see section 16.1.

## 2. Referenced Documents

2.1 *ASTM Standards*:<sup>2</sup>

[D121 Terminology of Coal and Coke](#)

[D2013 Practice for Preparing Coal Samples for Analysis](#)

[D2234/D2234M Practice for Collection of a Gross Sample of Coal](#)

[D4621 Guide for Quality Management in an Organization That Samples or Tests Coal and Coke \(Withdrawn 2010\)](#)<sup>3</sup>

[D4702 Practice for Quality Management of Mechanical Coal Sampling Systems \(Withdrawn 2008\)](#)<sup>3</sup>

[D4749 Test Method for Performing the Sieve Analysis of Coal and Designating Coal Size](#)

[D4916 Practice for Mechanical Auger Sampling \(Withdrawn 2008\)](#)<sup>3</sup>

[D6518 Practice for Bias Testing a Mechanical Coal Sampling System \(Withdrawn 2008\)](#)<sup>3</sup>

[D7256/D7256M Practice for Mechanical Collection and Within-System Preparation of a Gross Sample of Coal from Moving Streams \(Withdrawn 2008\)](#)<sup>3</sup>

[E105 Practice for Probability Sampling of Materials](#)

[E122 Practice for Calculating Sample Size to Estimate, With Specified Precision, the Average for a Characteristic of a Lot or Process](#)

[E177 Practice for Use of the Terms Precision and Bias in ASTM Test Methods](#)

[E456 Terminology Relating to Quality and Statistics](#)

[E691 Practice for Conducting an Interlaboratory Study to Determine the Precision of a Test Method](#)

## 3. Terminology

3.1 *Definitions*—Definitions applicable to this practice are listed in Terminology [D121](#).

3.2 *Definitions of Terms Specific to This Standard*:

3.2.1 *accuracy, n*—(1)generally, a term used to indicate the reliability of a sample, a measurement, or an observation; (2)specifically, a measure of closeness of agreement between an experimental result and the true value. An example is the observed and true sulfur content of a coal consignment. This measurement is affected by chance errors as well as by bias.

3.2.2 *activation interval, n*—for a falling-stream or cross-belt cutter, the time from the beginning of movement for taking an increment, to the beginning of movement for taking of the next increment.

<sup>2</sup> For referenced ASTM standards, visit the ASTM website, [www.astm.org](http://www.astm.org), or contact ASTM Customer Service at [service@astm.org](mailto:service@astm.org). For *Annual Book of ASTM Standards* volume information, refer to the standard’s Document Summary page on the ASTM website.

<sup>3</sup> The last approved version of this historical standard is referenced on [www.astm.org](http://www.astm.org).

3.2.3 *auger increment, n*—the retained portion of one extraction operation of the auger.

3.2.4 *auger sampler, n*—a mechanical device that extracts a columnar sample of coal from a railcar, truck, barge or stockpile and any associated sub-system or within-system components.

3.2.5 *bias, n*—the difference between the population mean of the mechanical sampler test results and the accepted reference value.

3.2.6 *confidence interval, n*—a numeric interval with a lower limit and a higher limit within which the true parameter value is estimated to fall. The confidence interval percentage indicates the percentage of time the true value will fall within the interval if the procedure is continuously repeated.

3.2.7 *consignment, n*—a discrete amount of coal, such as a shipment, a car load, a unit train, or a day's production. A consignment may include more than one lot of coal and may correspond to a specific period of time, such as a sampling period or a billing period.

3.2.8 *correlation, n*—a measure of the linear dependence between paired system and reference measurements. Correlation frequently is expressed by the correlation coefficient, which can take a value from minus one (perfect negative linear relationship) to plus one (perfect positive linear relationship).

3.2.9 *cross-belt sampler, n*—a single sampling machine or component of a mechanical sampling system designed to extract an increment directly from a conveyor belt surface by sweeping a sampling device (cutter) through the material on the conveyor.

3.2.10 *delimitation error, n*—a material error that occurs when all the elements in a cross section of a coal stream do not have an equal probability of being intercepted (captured) by the sampler cutter during increment collection.

3.2.11 *ellipsoidal region, n*—an area that is formed by plane sections of ellipses that are defined by the values selected for the largest tolerable bias of each coal characteristic used in the bias test. The region will be used to determine if the system is biased.

3.2.12 *falling-stream sampler, n*—a single sampling machine or component of a mechanical sampling system designed to extract an increment from a falling stream of coal at the discharge end of a conveyor or chute by moving a sampling device (cutter) through the falling stream of material.

3.2.13 *Hotelling's T<sup>2</sup> test, n*—a statistical test that is used to evaluate multivariate data. It is the multivariate equivalent of the Student's *t*-test.

3.2.14 *largest tolerable bias (LTB), n*—an interval whose upper and lower bounds represent the limits of an acceptable bias.

3.2.15 *mechanical sampling system, n*—a single machine or series of interconnected machines whose purpose is to extract mechanically, or process (divide and reduce), or a combination thereof, a sample of coal.

3.2.16 *paired data set, n*—system and reference values observed on samples collected and compared from the same batch of material.

3.2.17 *precision, n*—a term used to indicate the capability of a person, an instrument, or a method to obtain reproducible results; specifically, a measure of the chance error as expressed by the variance, standard error, or a multiple of the standard error (see Practice E177).

3.2.18 *reference sample, n*—a sample used in testing of a mechanical sampling system which is comprised of one or more increments collected from the test batch or lot of coal by the stopped belt method as described in Practice D2234/D2234M.

3.2.19 *reject stream, n*—the coal flow within a mechanical sampling system, which occurs at each stage of division, before and after reduction, and is not included in the system sample.

3.2.20 *sampling ratio, n*—the mass of the system sample divided by the mass of the corresponding coal sampled.

3.2.21 *save stream, n*—the coal flow within a mechanical sampling system which occurs at each stage of division, before and after reduction, and after the final stage of division becomes the system sample.

3.2.22 *statistical independence, n*—two sample values are statistically independent if the occurrence of either one in no way affects the probability assigned to the occurrence of the other.

3.2.23 *surrogate sample, n*—a sample, used in the evaluation of a mechanical sampling system, which is comprised of one or more increments collected from a coal stream within the mechanical sampling system in accordance with Practice D2234/D2234M, Conditions "A" or "B." Such a sample may be considered acceptable for evaluation of a mechanical sampling system's components, excluding the primary cutter, when demonstrated to be equivalent to the reference sample.

3.2.24 *system sample, n*—a sample collected from a test batch or lot of coal by the final stage of a mechanical sampling system.

3.2.25 *unbiased sample (representative sample), n*—a sample free of bias.

3.2.26 *Walsh averages, n*—given a series of observations (differences)  $x_1, x_2, \dots, x_n$ , the  $n(n+1)/2$  pair-wise averages given by:

$$(x_i + x_j)/2, 1 \leq i < j \leq n \quad (1)$$

### 3.2.26.1 Discussion—

As an example of Walsh averages, assume one has three observations (differences) designated as  $x_1$ ,  $x_2$ , and  $x_3$ . There are then a total of  $3(4)/2 = 6$  Walsh averages. They are as follows:  $x_1$ ,  $x_2$ ,  $x_3$ ,  $(x_1 + x_2)/2$ ,  $(x_1 + x_3)/2$ , and  $(x_2 + x_3)/2$ .

3.2.27 *Wilcoxon Signed Rank Test, n*—a non-parametric statistical procedure for calculating the point estimate and confidence interval for a sample drawn from a population with symmetric distribution.

3.2.28 *within-system preparation, n*—the process of gross sample preparation carried out mechanically by sequential crushing (reduction) equipment and/or division equipment. It may be carried out by processing increments individually or by batching increments together and processing them together as a group. In any case, within-system preparation is conducted in a manner to minimize moisture changes and without removing the gross sample or its increments from the sampling system.

## iTeh Standards (<https://standards.iteh.ai>) Document Preview

[ASTM D7430-15](#)

<https://standards.iteh.ai/catalog/standards/sist/31cedcca-3849-4e77-9ce4-25bccf60bac0/astm-d7430-15>

**PART A – MECHANICAL COLLECTION AND WITHIN-SYSTEM PREPARATION OF A GROSS SAMPLE OF COAL FROM MOVING STREAMS**  
**[Old Practice D7256/D7256M]**

**4. Summary of Practices**

4.1 The general-purpose sampling procedures are intended to provide, in 19 of 20 cases, dry ash results that are within an interval of  $\pm 1/10$  of the average dry ash results that would be obtained in hypothetical repeated sampling.

4.2 Special-purpose sampling procedures apply to the sampling of coal when other precision limits are required, or when other constituents are used to specify precision, or for performance tests.

4.3 For coals of known size and condition of preparation, a table (Table 1) is given for the determination of the number and weight/mass of increments required for a gross sample for both general- and special-purpose sampling.

4.4 The only processes of sample division and reduction covered in this document are the use of mechanical sample dividers for the division of the sample, and mechanical crushing equipment for the reduction of the sample, both of which are within-system components of the mechanical sampling system.

4.5 The procedures appear in the following order:

Test Method	Section
Sampling of Coals Based on Size and Condition of Preparation	8.1
General-Purpose Sampling Procedure	8.1.1
— Number and Weight of Increments	8.1.1.2
— Number and Mass of Increments	8.1.1.2
Number of Gross Samples	8.1.1.4
Special-Purpose Sampling	8.1.2
— Number and Weight of Increments	8.1.2.2
— Number and Mass of Increments	8.1.2.2
Number of Gross Samples	8.1.2.3
Division of the Gross Samples Before Crushing	8.2
Reduction and Division	8.3

**5. Significance and Use**

5.1 It is intended that this practice be used to provide a sample representative of the coal from which it is collected. Because of the variability of coal and the wide variety of mechanical sampling equipment available, caution should be used in all stages of the sample collection process, the design of sampling system specifications, the equipment procurement and the acceptance testing of installed equipment.

5.2 After removal from the sampling system and further preparation (Practice D2013), the sample may be analyzed for a number of different parameters. These parameters may define the lot's value, its ability to meet specifications, its environmental impact, as well as other properties.

**TABLE 1 Number and Weight/Mass of Increments for General-Purpose Sampling Procedure<sup>A</sup>**

Top Size	16 mm [5/8 in.]	50 mm [2 in.]	150 mm [6 in.] <sup>B</sup>
Mechanically Cleaned Coal <sup>C</sup>			
Minimum number of increments	15	15	15
Minimum weight of increments, kg [lb]	1 [2]	3 [6]	7 [15]
Minimum mass of increments, kg [lb]	1 [2]	3 [6]	7 [15]
Raw (Uncleaned Coal) <sup>C</sup>			
Minimum number of increments	35	35	35
Minimum weight of increments, kg [lb]	1 [2]	3 [6]	7 [15]
Minimum mass of increments, kg [lb]	1 [2]	3 [6]	7 [15]

<sup>A</sup> Conditions C and D are not addressed in this standard.

<sup>B</sup> For coals above 150-mm [6-in.] top size, the sampling procedure should be mutually agreed upon in advance by all parties concerned.

<sup>C</sup> See 7.2.2.

## 6. Increment Collection Classification

6.1 The type of selection, the conditions under which individual increments are collected, and the method of spacing of increments from the coal consignment or lot are classified according to the following descriptions and Table 1 in Practice [D2234/D2234M](#).

6.2 *Types of Increments*—the only type of selection of increments covered by this document are Type I where there is no human discretion in the selection of the pieces of coal or portions of the coal stream. Type I selection increments generally yield more accurate results than Type II where human discretion is exercised in the selection of specific pieces of coal or of specific portions of the stream, pile, or shipment.

6.3 *Conditions of Increment Collection*—The conditions under which individual increments are collected are the conditions of the main body of coal relative to the portion withdrawn. Only Condition B (Full-Stream Cut), in which a full cross-section cut is removed from a moving stream of coal is covered by this document.

6.4 *Spacing of Increments*—The spacing of increments pertains to the kind of intervals between increments. Two spacing methods are recognized: systematic and random. Systematic spacing is usually preferable.

6.4.1 *Systematic Spacing 1*, in which the movements of individual increment collection are spaced evenly in time or in position over the lot. This standard allows both time-based and mass-based distribution of increments.

6.4.2 *Random Spacing 2*, in which the increments are spaced at random in time or in position over the lot.

## 7. Organization and Planning of Sampling Operations

7.1 This practice provides definitive procedures for the collection of a gross sample. Parties claiming to use this practice must adhere to the procedures as set out in this standard. If the sampling is not done in accordance with the procedures set out in this practice then that sample may not be suitable for comparison with a sample collected by the procedures described in this practice. Since it may be impracticable or impossible to take another sample of a given lot of coal it is essential that parties agree on sampling procedures prior to undertaking sampling.

7.2 *Selection of Appropriate Sampling Procedure*—Variations in coal-handling facilities make it impossible to publish rigid rules covering every sampling situation in complete and exact detail. Proper sampling involves an understanding and proper consideration of the minimum number and weight/mass of increments, the size consist of the coal, the condition of preparation of the coal, the variability of the constituent sought, and the degree of precision required.

7.2.1 *Number and Weight/Mass of Increments*—The number and weight/mass of increments required for a given degree of precision depends upon the variability of the coal. This variability increases with an increase in free impurity. A coal high in inherent impurity and with comparatively little free impurity may exhibit much less variability than a coal with a low inherent impurity and a relatively high proportion of free impurity. For most practical purposes, an increase in the ash content of a given coal usually indicates an increase in variability. It is imperative that not less than the minimum specified number of increments of not less than the minimum specified weight/mass be collected from the lot.

7.2.2 *Condition of Preparation*— If there is any doubt as to the condition of preparation of the coal (for example, mechanically cleaned coal or raw coal), the number of increments for raw coal shall apply. For the purpose of application of the minimum number of increments in [Table 1](#), mechanically cleaned coal is defined as coal, which has been mechanically cleaned by a specific gravity process in all sieve sizes above No. 100 USA Standard. Similarly, although a coal has been mechanically cleaned it may still show significant variation. For example, the coal may be a blend of two different portions of one seam or a blend of two different seams. In such cases where significant variation is possible, the number of increments should be as specified for raw (uncleaned) coal.

7.3 *Distribution of Increments*—It is essential that the increments be distributed throughout the lot to be sampled. This distribution is related to the entire volume of the lot, not merely its surface or any linear direction through it or over it. If circumstances prevent the sampler from applying this principle, the lot is sampled only in part, and the gross sample is representative only of this part. The spacing of the increments shall be varied if the possibility exists that increment collection may get “in phase” with the sequence of coal variability. Example: routine sampling of commercial coal from a continuous stream (conveyor belt) in which increment collection is automatic and its sequence coincides with the “highs” or “lows” in the content of fines.

7.3.1 *Independence of Cutter Activation Intervals*—Select cutter activation intervals so that cutters do not activate at a set time in relation to the cutter from a previous stage. In addition, the activation interval for any sampling stage shall not be evenly divisible into the previous stage activation interval.

7.4 *Dimensions of Sampling Device*—The opening of the sampling device shall be no less than 3.0 times the nominal top size of the coal but no less than 30 mm [1.25 in.]

7.4.1 For systems installed prior to December 31, 2013, the opening of the sampling device may be 2.5 times the nominal top size of the coal but no less than 30 mm [1.25 in.].

7.4.2 The sampling device shall be of sufficient capacity to completely retain or entirely pass the increment without spillage at the maximum rate of coal flow.

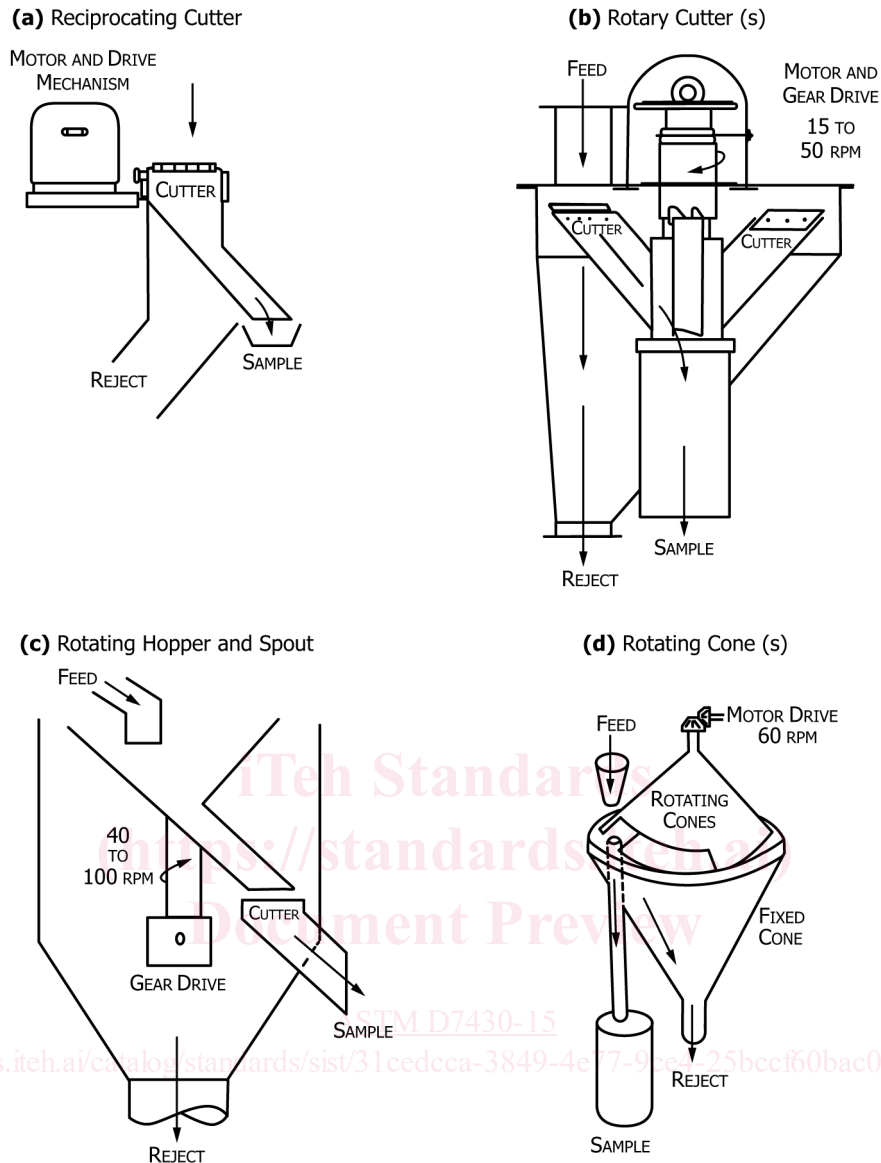

(a) *Reciprocating Cutter*—Fig. 1 (a) shows a section of a cutter which is moved across a stream of coal. At regular intervals, the cutter movement is reversed and a sample increment is collected on each trip through the coal stream.

(b) *Rotating Cutter*—Fig. 1 (b) shows two cutters attached to a hollow, rotating shaft. Each cutter is designed to extract increments from the feed and to discharge these into the hollow shaft. One or more cutters may be used.

(c) *Rotating Hopper and Spout*—Fig. 1 (c) shows the totaling hopper that receives the crushed sample and discharges it through a spout over one or more stationary cutters.

(d) *Rotating Cone*—Fig. 1 (d) shows a sampler developed by the British National Coal Board. Two slotted cones are locked together and rotated on a vertical shaft so that on each revolution the common slot operating intercepts the falling stream of coal and collects an increment.

**FIG. 1 Mechanical Sample Dividers**

**7.5 Characteristics and Movement of Sampling Device**—In sampling from moving streams of coal, the sampling device shall be designed to collect each increment with no selective rejection of material by size and with no contamination by nonsample material.

**7.5.1 Falling-Stream Sampler**—In collecting an increment, the falling-stream cutter moves at a constant velocity through the entire cross section of the stream of coal. The mass  $m$ , in kg [lb] of material collected in one pass through the stream by a falling-stream cutter, with cutting edges and cutter velocity perpendicular to the stream flow, is calculated from the following equation:

$$m = \frac{Cw}{3.6v_c} \left[ m = \frac{Cw}{1.8v_c} \right] \quad (2)$$

where:

$C$  = stream flow rate in Mg/h [ton/h],

$w$  = tip-to-tip cutter aperture width in mm [in.], and

$v_c$  = average cutter speed in mm/s [in./s].

NOTE 1—Falling stream cutter speeds of 460 mm/s [18 in./s] or less have been found to produce acceptable results.

NOTE 2—The constant value 3.6 [1.8] in the denominator of Eq 2 converts Mg/h to kg/s [ton/h to lb/s].

NOTE 3—If the falling-stream cutter velocity is not constant as it traverses the material stream, the mass of collected material may not agree with that calculated using Eq 2.

7.5.2 *Cross-Belt Sampler*—Design and operate the cross-belt cutter at a velocity across the conveyor surface that is high enough to prevent selective rejection of material by size, prevent contamination of the sample with material not collected within the cutter, and avoid mechanical problems due to damming of conveyed material against the outside of the cutter body as the cutter travels through the stream. Furthermore, assure by design that a complete increment is extracted, and that the arc of travel of the cross-belt cutter closely fits the configuration of the conveyor belt. The mass  $m$ , in kg [lb], of material collected in one pass through the moving stream by a cutter with cutting edges and cutter velocity perpendicular to the stream flow is calculated from the following equation:

$$m = \frac{Cw}{3.6v_b} \left[ m = \frac{Cw}{1.8v_b} \right] \quad (3)$$

where:

$C$  = stream flow rate in Mg/h [ton/h],

$w$  = tip-to-tip cutter aperture width in mm [in.], and

$v_b$  = conveyor belt speed in mm/s [in./s].

NOTE 4—The constant value 3.6 [1.8] in the denominator of Eq 3 converts Mg/h to kg/s [ton/h to lb/s].

NOTE 5—To avoid mechanical problems and spillage and to assure correct sample delimitation the higher ratio of cutter speed to belt speed the better. Ratios of cutter speed to belt speed of 1.5 or greater have been found to produce acceptable results.

7.6 There shall be no structural member or other impediment within a cutter body that impedes either sample collection or sample discharge.

7.7 *Preservation of Moisture*—The increments obtained during the sampling period shall be protected from changes in composition as a result of exposure to rain, snow, wind, sun, contact with absorbent materials, and extremes of temperature. The circulation of air through equipment must be reduced to a minimum to prevent both loss of fines and moisture. Samples in which moisture content is important shall be protected from excessive air flow and then shall be stored in moisture-tight containers. Metal cans with airtight lids, or heavy vapor-impervious bags, properly sealed, are satisfactory for this purpose.

7.8 *Contamination*—The sampling arrangement shall be planned so that contamination of the increments with foreign material or unrelated coal does not create bias of practical consequence.

7.9 *Mechanical System Features*—It is essential that mechanized systems as a whole, including sampling machines, chutes, feed conveyors, crushers and other devices, be self-cleaning and non-clogging and be designed and operated in a manner that will facilitate routine inspection and maintenance.

7.10 *Personnel*—Because of the many variations in the conditions under which coal must be sampled, and in the nature of the material being sampled, it is essential that the samples be collected under the direct supervision of a person qualified by training and experience for this responsibility.

7.11 *Criteria of Satisfactory Performance*—A satisfactory sampling arrangement is one that takes an unbiased sample at the desired degree of precision of the constituent for which the sample is to be analyzed. One fundamental characteristic of such an arrangement is that the size consist of the sample will adequately represent the true size consist of the coal. Sampling systems shall be tested initially and at regular intervals to determine whether the sample adequately represents the coal. In addition, give sampling systems a performance check as a matter of routine. This is done by comparing the weight/mass or volume of collected sample with that of the total flow of coal to ensure a constant sampling ratio. Information on the quality assurance of mechanical sampling systems can be found in Part C.

7.12 *Relative Location of Sampling and Weighing*—It is preferable that coal be weighed and sampled at the same time. If there is a lapse in time between these two events, consideration should be given by both the purchaser and the seller to changes in moisture during this interval and the consequent shift in relationship of moisture to the true quality of the coal at the instant when ownership of the coal transfers from one to the other.

## 8. Procedures

### 8.1 Sampling of Coals Based on Size and Condition of Preparation:

#### 8.1.1 General-Purpose Sampling:

8.1.1.1 Where probability sampling is employed, the general-purpose sampling procedures are intended to provide, in 19 of 20 cases, dry ash results that are within the interval of  $\pm 1/10$  of the average dry ash results that would be obtained in hypothetical repeated sampling.



8.1.1.2 *Number and WeightMass of Increments*—Obtain the number and weightmass of increments as specified in **Table 1** except as provided in 8.1.1.5(2). Determine the minimum number of increments from the condition of preparation, and determine the minimum weightmass of each increment from the top size of the coal. Classify the coals to be sampled according to the general purpose procedure into three groups by top size. Further classify each of these groups into two subgroups in accordance with the condition of preparation. These classifications are shown in **Table 1**.

8.1.1.3 Variations in construction of the sampling device and flow, structure, or size consist of the coal may make it impracticable to collect increments as small as the minimum weightmass specified in **Table 1**. In such cases, collect an increment of greater weightmass. However, do not reduce the minimum number of increments, regardless of large excesses of individual increment weights-masses. **Table 1** lists the absolute minimum number of increments for general-purpose sampling which may not be reduced except as specified in 8.1.1.5(2). Other considerations may make it advisable or necessary to increase this number of increments.

8.1.1.4 *Number of Gross Samples*—Under the general-purpose sampling procedure, for quantities up to approximately 1000 Mg [1000 tons] it is recommended that one gross sample represent the lot. Take this gross sample in accordance with the requirements prescribed in **Table 1**.

8.1.1.5 For quantities over 1000 Mg [1000 tons], use any of the following alternatives:

(1) Take one gross sample for the lot and analyze it to represent the quality of the lot. Collect the number of increments  $N$  calculated from **Eq 4**:

$$N = K \sqrt{\frac{L}{1000}} \quad (4)$$

where:

$L$  = number of Mg [tons], and

$K$  = 15.7 [15] for mechanically cleaned coal or 36.7 [35] for raw coal.

(2) Divide the lot into sub-lots and take a separate gross sample from each sub-lot. Use **Eq 4** to determine the minimum number of increments for each sub-lot, with  $L$  being the sub-lot quantity. Weight-average the analyses of the sub-lot samples to represent the quality of the original lot.

8.1.1.6 The maximum lot size shall be chosen by mutual agreement between the seller and the buyer of the coal, with each party taking into account the risks associated with the choice. Potential consequences include:

(1) Large samples requiring excessive off-line preparation steps can result in sampling moisture losses.

(2) No quality information is obtained on within-lot variability. Lot sizes generally should not exceed quantities for which critical quality levels apply in use of the coal.

(3) When a given quantity of coal that might be represented by a single lot is divided into multiple sub-lots, the imprecision of the reported quality for that given quantity is reduced. For a given quantity, the component of imprecision due to sample preparation and analysis is reduced by  $1/\sqrt{m}$  where  $m$  is the number of sub-lots.

### 8.1.2 *Special-Purpose Sampling:*

8.1.2.1 This special-purpose sampling procedure shall apply to the sampling of coal when increased precision is required, and the only knowledge of the coal is its top size and conditions of preparation.

8.1.2.2 *Number and WeightMass of Increments*—Take the same number and weightmass of increments per gross sample as specified in **Table 1**, or as specified in 8.1.1.5(2).

8.1.2.3 *Number of Gross Samples*—To obtain increased precision for the final result for a given consignment, increase the number of gross samples collected from that consignment and analyze each gross sample separately, reporting the average of results. To reduce errors to one half, that is, to “double” the precision, take four times as many gross samples. Similarly, to reduce errors to one third, to “triple” the precision, take nine times as many gross samples.

### 8.1.3 *Sampling for Total Moisture Only:*

8.1.3.1 The increments as established in **Table 1** for mechanically cleaned coal are deemed adequate for general purpose sampling for total moisture.

### 8.2 *Division of the Gross Sample Before Crushing:*

8.2.1 Large primary increments may be divided in quantity before crushing by secondary sampling. In the case of dividing a primary increment before crushing, the minimum increment weightmass must meet the weightmass specified in **Table 1** for the top size listed.

8.2.1.1 If each primary increment is reduced in quantity by secondary sampling, take at least six secondary increments from each uncrushed primary increment. The method of collection of secondary increments must be proved to be free from bias. In no case shall the weightmass of a secondary increment be less than shown in the schedule of **Table 1**.

### 8.3 *Reduction and Division:*

8.3.1 Reduce the gross or divided sample in stages and divide by suitable mechanical sample dividers (see 8.4.2) to quantities not less than those shown in **Table 1** of Practice **D2013**.

8.3.2 Mechanical division of the sample consists of automatically collecting a large number of increments of the properly reduced sample. Distribute this large number of increments equally throughout the entire discharge from the sample crusher because crushers can introduce appreciable segregation. At each stage of division, take at least 60 increments.

NOTE 6—Reduction and division of the mechanical samples that do not involve within-system components of the mechanical sampling system are not covered by this document but governed by Practice D2013.

NOTE 7—It is recommended that, in the case of mechanical division in which an increment is not thoroughly mixed with other increments before division, a portion of each increment be collected by the subsequent stage increment collection process.

#### 8.4 *Reduction and Division Apparatus:*

8.4.1 *Crushers or Grinders*—Jaw, cone, or rotary crusher; hammer mill; roll; or other suitable crusher to reduce the sample. Design and operate crushers in a manner to minimize the effect of induced air circulation and thus the potential for drying the coal.

8.4.1.1 *Hammer Mill*—Completely enclosed to avoid loss of dust or moisture.

8.4.2 *Sample Dividers: Mechanical*—A mechanical sample divider using a reciprocating or rotating cutter, a rotating hopper and spout, a rotating slotted cone, a reciprocating hopper and fixed cutter, bucket cutter with either bottom dump or inverting discharge, slotted belt, rotary disk divider, mechanical stopped or moving belt sweeper, or other acceptable devices for dividing the sample. Typical mechanical sample dividers are shown in Fig. 1. These illustrate various designs, but other acceptable designs are available.

### 9. Maintenance of Mechanical Sampling Equipment

9.1 Design mechanical sampling equipment to facilitate inspection, cleaning and maintenance.

9.1.1 Ensure that hatches and doors are located to provide easy access to key areas of the sampler such as: (a) cutters in their parked positions, (b) high wear items like crusher components, belt wipers or the wiping edge of cross-belt cutters, and (c) points of potential pluggage within the system; etc.

9.1.2 Enable hatches and doors to be quickly and easily opened, closed and secured, and include seals that make them air and dust tight.

9.1.3 Provide adequate access to the sampler (for example using permanent walkways, ladders, platforms, etc.) so that personnel can work effectively on and around the sampling equipment.

9.2 Wear of mechanical components may eventually cause a system, which had originally been checked satisfactorily for bias, to produce biased samples. Inspect mechanical systems frequently and in accordance with a planned maintenance scheme in order to ensure continuous reliable operation by detecting and repairing system components that have undergone wear beyond a critical level or are broken.

### 10. Precision and Bias

10.1 The precision of the general-purpose sampling procedure, based on size and condition of preparation, is stated in 8.1.1.1. If a different precision is required, see 8.1.2.

10.2 Mechanical sampling systems are tested for bias using the procedures of Part D.

**PART B – MECHANICAL AUGER SAMPLING**  
**[Old Practice D4916]**

**11. Summary of Practices**

11.1 A sample of coal is extracted from a stationary load contained within a railcar(s), truck(s), or barge(s) by inserting an auger into the vehicle in a vertical manner to extract a columnar sample of coal from the vehicle. Protect the coal collected by the auger, or processed by additional sampling components, from moisture change and contamination by placing it into containers and sealing them.

**12. Significance and Use**

12.1 Auger sampling systems may be used to extract samples from trucks, railcars, barges, or static compacted stockpiles where the use of a full-stream mechanical sampling system may be impractical. The samples obtained from these systems can be used to establish the materials' commercial value or constituents for quality control purposes at the shipping or receiving location of the interested parties in the transaction. The utilization of an auger system and procedures for collecting coal samples for subsequent analysis should be agreed upon by all parties concerned. Compacted stockpiles should be no higher than the length of the auger sampler. Otherwise, the deeper areas of the stockpile cannot be sampled.

**13. Organization and Planning of Sampling Operations**

13.1 *General Considerations*—Mechanical auger sampling is designated as Condition D, Stationary Coal Sampling. When using augers to sample, the material taken may only be representative to the depth sampled. In addition, the parameters such as top size, degree of preparation, degree of material segregation, and pattern of auger placement should also be considered.

13.2 *Consideration of Top Size*—Designs of mechanical sampling augers vary from high-powered augers with cutter bits drilling through the coal to be sampled, to low-powered augers designed to sample loosely compacted coal. The clearance in the auger assembly and flights should be sufficient to allow passage of the largest top size in the lot of coal to be sampled. If the top size of coal makes the auger size impractical, the auger should be designed to cut through or break up the lumps of coal.

13.3 *Consideration for Number of Auger Increments*—The number of increments required should be based on the lot size and degree of material preparation. For purposes of this practice, the degree of preparation is divided into two categories, that is, raw and mechanically cleaned. The lot size may be determined by factors such as prior contractual agreements, operational restrictions, coal storage capabilities, and coal transportation methods such as rail car, truck, or barge. Determine the number of increments required to represent the lot by following Eq 4 in 8.1.1.5.

13.3.1 Determine recommendations for the number of auger increments per vehicle by the following formula:

$$N_3 = N_2 \times b/a \tag{5}$$

where:

- $N_2$  = number of increments required,
- $N_3$  = number of increments per vehicle,
- $a$  = lot size, Mg [tons], and
- $b$  = amount of material per vehicle, Mg [tons].

If  $N_3$  is greater than one, round it off to the nearest whole number. If  $N_3$  is less than one, it is recommended that one increment be taken from each vehicle.

13.3.2 However, if operational considerations make the application of these procedures impractical, the following suggestions may be considered:

13.3.2.1 *Example 1*—When more than one increment per vehicle is recommended but deemed impractical, then take as many increments as possible, but never less than one increment per vehicle. It should be realized that any reduction in the number of increments could reduce the precision of the final sample. In any case, obtain the same number of increments from each vehicle within the lot.

13.3.2.2 *Example 2*—When  $N_3$  is less than one and one increment per vehicle has not been selected as practical, then use the following procedure: take the reciprocal of  $N_3$  (that is, calculate  $1/N_3$ ) and round off this value to the nearest whole number. This is now the number of vehicles per increment. Next, space the increments over the number of vehicles either systematically or randomly while noting these precautions; although systematic spacing (for example, one increment every second vehicle for 100 vehicles) may be preferred in other sampling practices, practical consideration must be given to the phenomena of cyclical variability which is common in this type of sampling operation. If systematic spacing is not chosen, random spacing (for example, distributing the 50 increments randomly over the next 100 vehicles) must ensure the elimination of human discretion. This may be done by preplanning and the use of various random-number generator schemes.

13.3.2.3 *Example 3*—When sampling a leveled, compacted stockpile, consideration must be given to the number of increments necessary to represent the lot. It is recommended that a stockpile be divided into lots of not over 45 Mg [50 tons]. The number of increments required per lot size would be in accordance with 13.3 of this practice.

13.4 *Considerations for Auger Placement Patterns and Increment Collections*—The ease of extracting the auger increments from various portions within the vehicle will be predicted upon the auger design, vehicle type, and support facility limitations. However, it is recommended that a random sampling location pattern be developed to maximize the number of locations from where the auger can extract an increment. Human discretion should be minimized with respect to auger placement to the extent possible. When the lot to be sampled is comprised of vehicles having different cargo capacities, the user should be aware that the auger increment extracted may result in a disproportionate representation of sample from certain vehicles within the lot.

13.4.1 *Sampling Leveled Compacted Stockpiles*—The shape of the area to be represented by each gross sample determines the grid pattern for increment collection. Increments are to be collected at the intersection of the grid pattern. Each grid section should represent equal area as near as possible.

13.4.1.1 The grid pattern must include the slope of the pile. Also, the slope of the pile may not be as compacted as the top. Take care to ensure adequate sampling of the slope.

13.4.2 *Stockpiles of Less than 3-m [10-ft] Height*—The preferred device to be utilized on stockpiles of less than 3 m [10-ft] height is a mobile, mechanical, truck-mounted auger. This device will penetrate to the pile base.

13.4.2.1 The use of an auger to sample a stockpile must be considered a Class D Method. It should be used only if a higher method is not possible. Because of auger design, all of the fine material from the bottom of a pile may not be collected. All parties should agree on the use of the auger method before it is used.

13.4.3 *Stockpiles of Greater than 3-m [10-ft] Height*—The preferred device to be utilized on a stockpile of over 3-m [10-ft] height is a hollow-stem auger and split-spoon sampler that will allow the deepest penetration into the pile and identify the base. If the hollow-stem auger and split-spoon sampler is used, the option of producing a three-dimensional grid exists. In a three-dimensional grid pattern, each grid must represent equal area. Increments are to be collected at the intersection of the grid pattern.

13.4.4 *Stockpile Sampling Records*—Sampling technicians should keep a written log with notations of all the conditions encountered during increment collection. Items to be noted may include size of the stockpile, size-segregation patterns, general configuration of the stockpile, weather conditions including the ambient temperature, degree of compaction of the stockpile, perimeter conditions of the pile, degree of contamination, and visual appearance of the material.

13.5 *Preservation of Moisture*—The increments obtained during the sampling period shall be protected from changes in composition due to exposure to rain, snow, wind, sun, contact with absorbent materials, and extremes of temperature. The circulation of air through equipment must be reduced to a minimum to prevent loss of both fines and moisture. Samples in which moisture content is important shall be protected from excessive airflow and stored in moisture-tight containers. Containers with airtight lids and heavy gage vapor-impervious bags tightly sealed are satisfactory for this purpose.

13.6 *Contamination*—The sampling arrangement shall be planned so that contamination of the increments with foreign material or unrelated coal is avoided.

13.7 *Mechanical System Features*—It is essential that the entire auger system, that is, cutters, chutes, conveyors, crushers, be self-cleaning and be designed in a manner that will minimize the need for maintenance.

13.8 *Personnel*—Because of the many variations in the conditions under which coal must be sampled, it is essential that the samples be collected under the direct supervision of a person qualified by training and experience for this responsibility. Where human discretion is employed in collecting the increments, it is essential that the samples be collected by a trained and experienced person or under the direct supervision of such a person.

13.9 *Relative Location of Sampling and Weighing*—It is preferable that coal be weighed and sampled at relatively the same time. If there is a lapse in time between these two events, consideration should be given by both the purchaser and seller to changes in moisture during this interval and the consequent shift in the relationship of moisture to the quality of the coal at the time when ownership transfers from seller to buyer.

13.10 *Reduction and Mechanical Division of the Auger Increments:*

13.10.1 *Division of Auger Increments Before Crushing:*

13.10.1.1 *Number of Increments*—If each retained increment is reduced in quantity by secondary sampling, take at least six secondary increments from each retained auger increment. This method of collection of secondary increments should be proven to be free from bias.

13.10.1.2 *Opening of Sampling Device*—The opening of the sampling device shall be at least 2½ to 3 times the top size of coal but in no case less than 31.8 mm [1¼ in.].

13.10.1.3 *Speed of Sampling Device*—To prevent segregation and rejection caused by disturbance of the coal stream, practical evidence indicates that the velocity with which the cutting instrument travels through the stream should not exceed 457 mm/s [18 in./s]. However, if greater cutter speeds are used, it is desirable to verify that they are free of bias under the normal range of expected conditions.

### 13.10.2 *Division of Auger Increment After Crushing:*

13.10.2.1 *Number of Increments*—Because of the various methods of loading and transporting material, stratification and segregation of material within the auger barrel may exist. This problem may be intensified by the nonuniformity in size of the crushed sample. It is recommended that a minimum of three secondary crushed increments per auger increment be collected and spaced evenly throughout the extracted auger increment.

13.10.2.2 In most auger installations involving on-line crushing, the sample is normally reduced in size to 10 mm [ $\frac{3}{8}$  in.] or less. Regardless of the final sample size, the cutter opening shall be no less than 31.8 mm [ $1\frac{1}{4}$  in.] in width. A cutter opening greater than 31.8 mm may be required in some cases to prevent bridging of the cutter opening, and consideration should be given to the material size, moisture content, coal-flow characteristics, and velocity at the cutter. In those cases where the auger increment is crushed to a larger top size than 10 mm, the cutter opening shall not be less than  $2\frac{1}{2}$  to 3 times the material top size.

13.10.2.3 *Speed of Sampling Device (After Crushing)*—To prevent segregation and rejection caused by disturbance of the coal stream, practical evidence indicates that the velocity with which the cutting instrument travels through the stream should not exceed 457 mm/s [18 in./s]. However, if greater cutter speeds are used, it is desirable to verify that they are free of bias under the normal range of expected conditions. Depending upon the sampler design, speeds slower than 457 mm/s may be desirable, especially when the cutter opening is set at the 38.1-mm dimension. Consideration should be given to the material feed angles to the sampler, particle size, moisture, flow characteristics, and flow rate to ensure nonpreferential extraction.

13.10.2.4 *Size of Increment*—In consideration of the individual increment ~~weights, masses,~~ each increment should be of a ~~weight, mass~~ sufficient to overcome internal factors such as airflow within the chutework, friction on the chute surfaces, and other factors affecting potential moisture losses. It is recommended that each secondary increment weigh a minimum of 50 g [1.8 oz].

## 14. Precision and Bias

14.1 At this time, sufficient performance data with respect to precision and bias is not available to establish statements in regard to the performance range for all of the auger designs and operating conditions.

iTeh Standards  
(<https://standards.iteh.ai>)  
Document Preview

[ASTM D7430-15](#)

<https://standards.iteh.ai/catalog/standards/sist/31cedcca-3849-4e77-9ce4-25bccf60bac0/astm-d7430-15>

**PART C – QUALITY MANAGEMENT OF MECHANICAL COAL SAMPLING SYSTEMS**  
**[Old Practice D4702]**

**15. Significance and Use**

15.1 This practice addresses quality assurance criteria for operation of a mechanical coal-sampling system in accordance with Part A, Practice D2013, and Part B. It provides recommendations for performance monitoring, inspection, and maintenance, which are necessary in maintaining a sampling system's capability to consistently obtain a representative sample.

**16. Hazards**

16.1 *Precautions*—In addition to other precautions, personnel visiting facilities for observation of mechanical sampling system performance should immediately upon arrival report to the facility management to inform them of their presence and the purpose of their visit. The inspector should ask for drawings, specifications, and instructions on the applicable safety practices and regulations to be followed on the site.

**17. Assessing the Organization and Planning of Sampling Operations**

17.1 It is recommended that inspection personnel meet with the appropriate personnel responsible for the mechanical sampling system, on all visits, to discuss the organization and planning of sampling operations. ASTM standards provide for the use of various options. Examples and references are given in 17.1.1 and 17.1.2 as follows:

17.1.1 *Cross-Belt and Falling-Stream Samplers*—The number of primary increments for the gross sample collected by cross-belt and falling-stream systems can be determined from 8.1.1.4 and 8.1.1.5 of Part A.

17.1.2 *Auger Sampling*—Considerations for the number of auger increments per lot and per vehicle are discussed in the Consideration for Number of Auger Increments section (13.3) of Part B.

17.2 Inspection personnel should refer to the sections of Part A and Part B referenced in 17.2.1 and 17.2.2 of this practice when assessing the conformance of the organization and planning of cross-belt, falling-stream, and auger sampling operations as follows:

17.2.1 *Planning of Cross-Belt or Falling-Stream Sampling Operations*—When assessing the conformance of the organization and planning of sampling operations for a specific cross-belt or falling-stream mechanical sampling system, the inspector should use Section 7, Organization and Planning of Sampling Operations, of Part A which covers the items that would be used in evaluating the sampling plan. Items covered are: Precautions, Selection of Appropriate Sampling Procedure, Number and Weight/Mass of Increments, Increment Collection Method to be Used, Distribution of Increments, Dimensions of Sampling Device, Movement of Sampling Device, Preservation of Moisture, Contamination, Mechanical System Features, Personnel, Criteria of Satisfactory Performance, and Relative Location of Sampling and Weighing.

17.2.2 *Planning of Auger Sampling Operations*—When assessing the conformance of the organization and planning of sampling operations for a specific auger sampling system, use Section 13, Organization and Planning of Sampling Operations, of Part B, which covers the following items: Precautions, Consideration of Top Size, Consideration for Number of Auger Increments, Considerations for Auger Placement Patterns and Increment Collections, Preservation of Moisture, Contamination, Mechanical System Features, Personnel, Relative Location of Sampling and Weighing, and Reduction and Mechanical Division of the Auger Increments.

**18. General Observations of Coal Stream Variability as Related to Primary Increment Collection by Falling-Stream and Cross-Belt Samplers**

18.1 The entire coal-handling system up to the cross-belt or falling-stream mechanical sampler should be examined to determine if any unloading, storage, or reclaiming procedures produce a cyclical pattern which could cause the increment collection to get *in phase* with the sequence of coal variability. Variations in the physical characteristics, such as particle-size distribution, surface moisture, extraneous matter, and oversized material, can become cyclical and even could be in phase with the time-based increment collection. When such cyclical variations occur in the coal stream, the source of the variations should be investigated to determine the practicability of eliminating the variations. If there is no practical way to eliminate the variations, then either the number of primary increments or the primary cutter velocity or both shall be varied.

NOTE 8—The number of primary increments should be varied by adjusting the time interval between primary cuts so that the period of cyclic variation is not evenly divisible by the number of primary cuts per period or by using a method of random collection of primary increments.

**19. General Observations of Auger Placement**

19.1 At a minimum, the inspector should examine the following two aspects of the placement of the auger over the surface of the coal being sampled: (1) human discretion in placement of the auger over the surface of the coal in the vehicle(s) and (2) the pattern of auger placement from vehicle to vehicle for lots comprised of more than one vehicle load of coal.