



Designation: ~~C1353/C1353M – 09~~<sup>e1</sup> C1353/C1353M – 15

# Standard Test Method for Abrasion Resistance of Dimension Stone Subjected to Foot Traffic Using a Rotary Platform, ~~Double-Head Platform~~ Abraser<sup>1</sup>

This standard is issued under the fixed designation C1353/C1353M; the number immediately following the designation indicates the year of original adoption or, in the case of revision, the year of last revision. A number in parentheses indicates the year of last reapproval. A superscript epsilon ( $\epsilon$ ) indicates an editorial change since the last revision or reapproval.

---

<sup>e1</sup> NOTE—The designation was corrected to Combined Units in October 2013.

---

## 1. Scope

1.1 This test method covers the establishment of an index of abrasion resistance by determination of loss of volume resulting from abrasion of dimension stone as described in Terminology [C119](#) and is based on Guide [G195](#).

1.2 *Units*—The values stated in either inch-pound units or SI units are to be regarded separately as standard. The values stated in each system may not be exact equivalents; therefore, each system shall be used independently of the other. Combining values from the two systems may result in non-conformance with the standard.

1.2.1 *Exception*—The formula for calculation of the result of this test method relies on the use of SI units; all measurements of weight in this test method shall be recorded in SI units.

1.2.2 *Exception*—As the equipment used in this test method was designed and initially fabricated using dimensions in inch-pound units, the values of equipment dimensions stated in SI units have been given as exact conversions to the nearest 0.1 mm.

1.3 This test method uses a rotary platform, ~~double-head platform~~ abraser to determine the loss in volume of dimension stone caused by abrasion under controlled conditions.

1.4 This test method is useful in indicating the differences in abrasion resistance between the various dimension stones. This test method provides one element in comparing stones of the same type.

1.5 *This standard does not purport to address all of the safety concerns, if any, associated with its use. It is the responsibility of the user of this standard to establish appropriate safety and health practices and determine the applicability of regulatory limitations prior to use.*

## 2. Referenced Documents

2.1 *ASTM Standards:*<sup>2</sup>

[C97 Test Methods for Absorption and Bulk Specific Gravity of Dimension Stone](#)

[C119 Terminology Relating to Dimension Stone](#)

[C121 Test Method for Water Absorption of Slate](#)

[G195 Guide for Conducting Wear Tests Using a Rotary Platform Abraser](#)

## 3. Terminology

3.1 *Definitions of Terms Specific to This Standard:*

3.1.1 *abraser*—wear testing instrument to evaluate abrasion resistance, also referred to as an abrader.

3.1.2 *abrasion cycle*—in abrasion testing, one or more movements of the abradant across a material surface, or the material surface across the abradant, that permits a return to its starting position. In the case of the rotary platform test method, it consists of one complete rotation of the specimen.

---

<sup>1</sup> This test method is under the jurisdiction of ASTM Committee [C18](#) on Dimension Stone and is the direct responsibility of Subcommittee [C18.01](#) on Test Methods. Current edition approved Sept. 1, 2009; Feb. 15, 2015. Published October 2009; April 2015. Originally approved in 1996. Last previous edition approved in 2008; 2009 as [C1353 – 08](#); [C1353 – 09](#)<sup>e1</sup>. DOI: 10.1520/C1353-C1353M-09E01; 10.1520/C1353\_C1353M-15.

<sup>2</sup> For referenced ASTM standards, visit the ASTM website, [www.astm.org](http://www.astm.org), or contact ASTM Customer Service at [service@astm.org](mailto:service@astm.org). For *Annual Book of ASTM Standards* volume information, refer to the standard's Document Summary page on the ASTM website.

3.1.3 *index of abrasion resistance, n*—a number calculated from the weight loss of a specimen subjected to a given number of revolutions against a standard bonded abrasive wheel.

3.1.4 *resurface*—procedure of cleaning and refreshing the running surface of an abrasive wheel prior to or during use in testing.

3.1.5 *sample, n*—a geometrically regular block of stone.

3.1.6 *test specimen, n*—a flat prism of specified size and shape cut from the submitted sample.

#### 4. Summary of Test Method

4.1 A specimen is abraded using rotary rubbing action under controlled conditions of pressure and abrasive action. The test specimen is mounted on a turntable platform and turns on a vertical axis, against the sliding rotation of two abrading wheels. One abrading wheel rubs the specimen outward toward the periphery and the other, inward toward the center. The resulting abrasion marks form a pattern of crossed arcs over an area of approximately 5 in.<sup>2</sup> [30 cm<sup>2</sup>]. Resistance to abrasion is evaluated by determination of the loss of volume due to abrasion and calculation of an index of abrasion resistance.

#### 5. Significance and Use

5.1 This test method provides a means to quantify the abrasion resistance of dimension stone and may be related to end-use performance, or used to comparatively rank material performance, or both. The resistance of dimension stone to abrasion, as measured on a testing machine in the laboratory, is generally only one of several factors contributing to wear performance as experienced in the actual use of the material. Calculation of predicted life should not be based on specific abrasion data alone.

5.2 The resistance of dimension stone to abrasion may be affected by factors including test conditions; type of abradant; pressure between the specimen and abradant; mounting ~~or tension~~ of the specimen; and type, kind, or amount of finishing materials.

5.3 Abrasion tests utilizing the rotary ~~platform, double-head platform~~ abramer may be subject to variation due to changes in the abradant during the course of specific tests. Depending on abradant type and test specimen, the abrading wheel surface may change (that is, become clogged) due to pick-up of finishing or other materials from test specimens. To reduce this variation, the abrading wheels may require ~~resurfacing after use~~ resurfacing.

#### 6. Apparatus

6.1 ~~Rotary Platform, Double-Head (RPDH) Abraser~~ Platform Abraser, ~~—~~consisting of the elements described in 6.1.1 – 6.1.5 (see Fig. 1).

6.1.1 A removable ~~turntable~~ specimen turntable platform, which includes a rubber pad, clamp plate, centrally located threaded post and nut. The turntable shall be motor driven and mounted so as to produce a circular surface travel of a flat specimen in the plane of its surface. The specimen platform shall rotate with no visible wobble. This can be checked with a dial indicator at the top outer edge of the platform to make sure it runs true within 0.02 in. [0.5 mm].

6.1.2 A motor capable of rotating the turntable platform at a speed of either  $72 \pm 2$  r/min or  $60 \pm 2$  r/min.

6.1.3 A pair of pivoted arms to which the abrasive wheels and accessory weights or counterweights are attached.

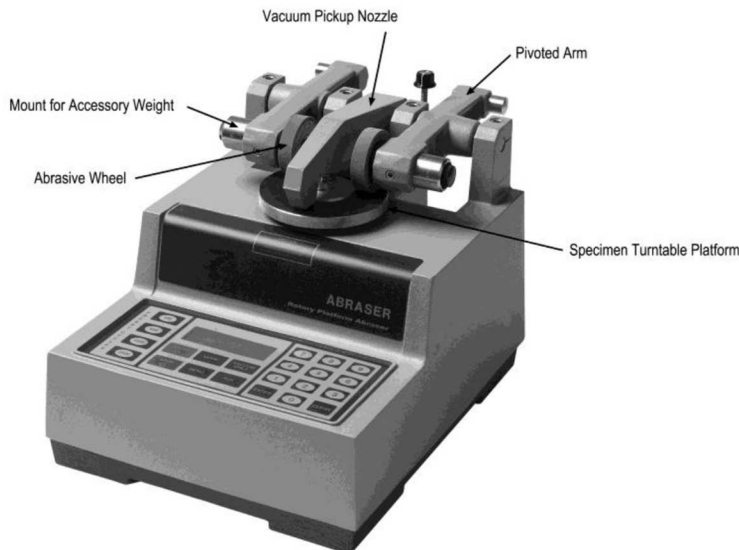

Note: Vacuum Suction System not shown

FIG. 1 Rotary Platform, Double-Head (RPDH) Abraser, with Dual Testing Platforms Platform Abraser

6.1.4 A vacuum suction system and vacuum pickup nozzle to remove debris and abrasive particles from the specimen surface during testing. The height of the vacuum pickup nozzle shall be adjustable, and the nozzle will have two  $\frac{3}{8}$  in. [8 mm] openings. One opening shall be positioned between the two wheels and over the wear path and the other placed diametrically opposite, with 3 in. [76.2 mm] distance between the axes of the two openings. The vacuum suction force at the surface of the specimen shall be sufficient to remove debris and abrasive particles.

6.1.5 A counter to record the number of abrasion cycles (revolutions) made by the turntable platform.

6.2 *Abrasive Wheels*<sup>3</sup>, which are attached to the free end of the pivoted arms and are able to rotate freely about horizontal spindles.

6.2.1 The wheels shall be  $\frac{1}{2}$  in. [12.7 mm] thick and have an external diameter of 2 in. [50.8[51.9 mm] when new, and in no case less than  $1\frac{3}{4}$  in. [41.3[44.4 mm]. The abrasive wheels shall be vitrified based, consisting of hard particles embedded in a binder material. H-22 Calibrade wheels are the required grade of abrasive for this test method.

6.2.2 The internal faces of the abrasive wheels shall be  $2\frac{1}{16}$  in. [52.4 mm] apart and the hypothetical line through the two spindles shall be  $\frac{3}{4}$  in. [19.1 mm] away from the central axis of the turntable (see Fig. 2). The wheels should be spaced equally on both sides from the wheel-mounting flange to the center of the specimen holder. The distance from the inside of the wheel mounting flange to the center of the specimen holder shall be  $1\frac{1}{2}$  in. [38.1[38.9 mm].

6.2.3 When resting on the specimen, the wheels will have a peripheral engagement with the surface of the specimen, the direction of travel of the periphery of the wheels and of the specimen at the contacting portions being at acute angles, and the angles of travel of one wheel periphery being opposite to that of the other. Motion of the abrasive wheels, in opposite directions, is provided by rotation of the specimen and the associated friction therefrom.

6.3 *Accessory Weights*<sup>3</sup>, to be attached to the pivoted arms to provide a force of 2.2 lb [1000 g], ~~which~~when the wheel is pressed against the specimen, exclusive of the mass of the wheel itself. Accessory weight references are per arm (not combined), and include the mass of the pivoted arm.

6.4 *Auxiliary Apparatus:*

6.4.1 Wheel refacer<sup>3</sup>, with a diamond tool for resurfacing vitrified wheels or correcting out of round wheels.

6.4.2 A soft bristle brush, to remove loose particles from the surface of the specimen after testing.

6.5 Balance, with a capacity of 1 lb [500 g] and capable of reading to two decimal places.

6.6 Desiccator containing a drying agent of sufficient size to contain samples to be tested.

6.7 Diamond saw (cut-off) with diamond-edged blade, cooled and flushed with water.

<sup>3</sup> The sole source of supply of the apparatus known to the committee at this time is Taber Industries, 455 Bryant Street, North Tonawanda, NY, 14120. If you are aware of alternative suppliers, please provide this information to ASTM International Headquarters. Your comments will receive careful consideration at a meeting of the responsible technical committee,<sup>1</sup> which you may attend. The Taber abraser is available in two models: the 5130 with a single platform or the 5150 with dual testing platforms. Both machines function in the same manner.

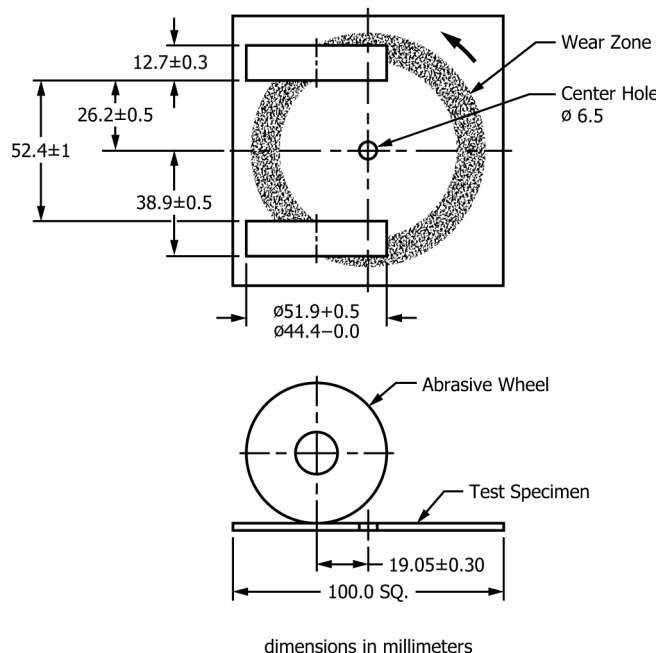

FIG. 2 Central Axis of the Turntable Diagrammatic Arrangement of Rotary Platform Abraser Test Set-up