



Designation: **E881–92 (Reapproved 2009) E881 – 92 (Reapproved 2015)**

Standard Practice for Exposure of Solar Collector Cover Materials to Natural Weathering Under Conditions Simulating Stagnation Mode¹

This standard is issued under the fixed designation E881; the number immediately following the designation indicates the year of original adoption or, in the case of revision, the year of last revision. A number in parentheses indicates the year of last reapproval. A superscript epsilon (ϵ) indicates an editorial change since the last revision or reapproval.

1. Scope

1.1 This practice covers a procedure for the exposure of solar collector cover materials to the natural weather environment at elevated temperatures that approximate stagnation conditions in solar collectors having a combined back and edge loss coefficient of less than $1.5 \text{ W}/(\text{m}^2 \cdot ^\circ\text{C})$.

1.2 This practice is suitable for exposure of both glass and plastic solar collector cover materials. Provisions are made for exposure of single and double cover assemblies to accommodate the need for exposure of both inner and outer solar collector cover materials.

1.3 This practice does not apply to cover materials for evacuated collectors, photovoltaic cells, flat-plate collectors having a combined back and edge loss coefficient greater than $1.5 \text{ W}/(\text{m}^2 \cdot ^\circ\text{C})$, or flat-plate collectors whose design incorporates means for limiting temperatures during stagnation.

1.4 *This standard does not purport to address all of the safety concerns, if any, associated with its use. It is the responsibility of the user of this standard to establish appropriate safety and health practices and determine the applicability of regulatory limitations prior to use.*

2. Referenced Documents

2.1 ASTM Standards:²

[D1435 Practice for Outdoor Weathering of Plastics](#)

[E765 Practice for Evaluation of Cover Materials for Flat Plate Solar Collectors \(Withdrawn 1991\)](#)³

[E772 Terminology of Solar Energy Conversion](#)

[E782 Practice for Exposure of Cover Materials for Solar Collectors to Natural Weathering Under Conditions Simulating Operational Mode](#)

[G7 Practice for Atmospheric Environmental Exposure Testing of Nonmetallic Materials](#)⁴

2.2 Other Documents:⁴

[Federal Specification HH-I-558B, Amendment 3, Insulation Blocks, Boards, Felts, Sleeving \(Pipe and Tube Covering\), and Pipe Fitting Covering Thermal \(Mineral Fiber, Industrial Type\) August 1976](#)

3. Terminology

3.1 Definitions:

3.1.1 For definitions of terms used in this practice, refer to Terminology [E772](#).

4. Significance and Use

4.1 This practice describes a weathering box test fixture and establishes limits for the heat loss coefficients. Uniform exposure guidelines are provided to minimize the variables encountered during outdoor exposure testing.

¹ This practice is under the jurisdiction of ASTM Committee [E44](#) on Solar, Geothermal and Other Alternative Energy Sources and is the direct responsibility of Subcommittee [E44.05](#) on Solar Heating and Cooling Systems and Materials.

Current edition approved April 1, 2009/March 1, 2015. Published June 2009/April 2015. Originally approved in 1982. Last previous edition approved in 2003/2009 as [E881-92\(2003\)](#); [E881-92\(2009\)](#). DOI: [10.1520/E0881-92R09](#); [10.1520/E0881-92R15](#).

² For referenced ASTM standards, visit the ASTM website, [www.astm.org](#), or contact ASTM Customer Service at [service@astm.org](#). For *Annual Book of ASTM Standards* volume information, refer to the standard's Document Summary page on the ASTM website.

³ The last approved version of this historical standard is referenced on [www.astm.org](#).

⁴ Federal Specification HH-I-558B has several classes of insulation material intended for high-temperature use.

4.2 Since the combination of elevated temperature and solar radiation may cause some solar collector cover materials to degrade more rapidly than either exposure alone, a weathering box that elevates the temperature of the cover materials is used.

4.3 This practice may be used to assist in the evaluation of solar collector cover materials in the stagnation mode. No single temperature or procedure can duplicate the range of temperatures and environmental conditions to which cover materials may be exposed during stagnation conditions. To assist in evaluation of solar collector cover materials in the operational mode, Practice E782 should be used. Insufficient data exist to obtain exact correlation between the behavior of materials exposed in accordance with this practice and actual in-service performance.

4.4 This practice may also be useful in comparing the performance of different materials at one site or the performance of the same material at different sites, or both.

4.5 Means of evaluating the effects of weathering are provided in Practice E765, and in other ASTM test methods that evaluate material properties.

4.6 Exposures of the type described in this practice may be used to evaluate the stability of solar collector cover materials when exposed outdoors to the varied influences that comprise weather. Exposure conditions are complex and changeable. Important factors are material temperature, climate, time of year, presence of industrial pollution, etc. Generally, because it is difficult to define or measure precisely the factors influencing degradation due to weathering, results of outdoor exposure tests must be taken as indicative only. Repeated exposure testing at different seasons over a period of more than one year is required to confirm exposure tests at any one location. Control samples must always be used in weathering tests for comparative analysis.

5. Weathering Box Test Fixture

5.1 Test Fixture Requirements:

5.1.1 The weathering box test fixture shall be constructed such that the combined back and edge loss coefficient is less than 1.5 W/(m² · °C) (0.264 Btu/(ft² · h · °F)) (Note 1). (The method for determining this coefficient is outlined in Appendix X1 of this practice.) The distance between the absorber and the closest cover plate shall be between 13 and 38 mm (0.5 and 1.5 in.). For a double-cover exposure the separation between the inner and outer cover shall be between 13 and 38 mm (0.5 and 1.5 in.). Not more than 10 % of the absorber plate area shall be shaded when the sun is at a 30° angle with the plane of the front surface of the exposure box.

NOTE 1—A good flat-plate solar collector has a combined back and edge loss coefficient of less than about 1.5 W/(m² · °C) (0.264 Btu/(ft² · h · °F)).

5.1.2 Boxes that meet the requirements of 5.1.1 are described in Table 1. Fig. 1 and Fig. 2 illustrate the weathering box test fixtures. Although Fig. 1 shows a square box, any shape is permitted if the requirements in 5.1.1 are met. Appendix X1 of this practice describes the method for determining the combined back and edge loss coefficient.

5.2 Contents of the Weathering Box Test Fixture: (1) a box, (2) insulation, (3) absorber, (4) box top, (5) spacer, (6) glazing frame, and (7) adhesive tapes.

5.2.1 The box may have any dimensions and be made of any material as long as the requirements in 5.1.1 are met. A weep hole shall be drilled at the lower end of the bottom of the box to provide drainage and to minimize moisture accumulation.

NOTE 2—It is desirable that the box and box top be made of a material that will be unaffected by the exposure environment. A metal resistant to

TABLE 1 Examples of Weathering Box Test Fixtures with Combined Heat Loss Coefficient for Back and Edge Losses Less than 1.5 W/(m²·°C) (0.264 Btu/(ft²·h·°F))

	Example 1	Example 2
Box material	steel	aluminum
Insulation material	glass fiber	glass fiber
<i>l</i> , length of aperture inside edge insulation	0.25 m (9.8 in.)	0.61 m (24 in.)
<i>w</i> , width of aperture inside edge insulation	0.13 m (5.2 in.)	0.61 m (24 in.)
<i>h</i> , distance from top of absorber to bottom of cover plate	0.013 m (0.5 in.)	0.038 m (1.5 in.)
<i>A_a</i> , area of aperture of test fixture <i>A_a</i> = (<i>l</i> × <i>w</i>)	0.033 m ² (51 in. ²)	0.372 m ² (576 in. ²)
<i>A_b</i> , area of back insulation <i>A_b</i> = (<i>l</i> × <i>w</i>)	0.033 m ² (51 in. ²)	0.372 m ² (576 in. ²)
<i>A_e</i> , area of edge insulation <i>A_e</i> = 2(<i>l</i> + <i>w</i>) <i>h</i>	0.01 m ² (15 in. ²)	0.093 m ² (144 in. ²)
<i>d_b</i> , thickness of back insulation	0.077 m (3 in.)	0.05 m (2 in.)
<i>d_c</i> , thickness of box	0.001 m (0.04 in.)	0.002 m (0.08 in.)
<i>d_e</i> , thickness of edge insulation	0.013 m (0.5 in.)	0.025 m (1 in.)
<i>K_b</i> , conductivity of back insulation	0.038 W/(m·°C) (0.22 Btu/(ft ² ·h·°F))	0.038 W/(m·°C) (0.022 Btu/(ft ² ·h·°F))
<i>K_c</i> , conductivity of box	43 W/(m·°C) (24.9 Btu/(ft ² ·h·°F))	204 W/(m·°C) (118 Btu/(ft ² ·h·°F))
<i>K_e</i> , conductivity of edge insulation	0.038 W/(m·°C) (0.022 Btu/(ft ² ·h·°F))	0.038 W/(m·°C) (0.022 Btu/(ft ² ·h·°F))
<i>A_b</i> / <i>A_a</i>	1	1
<i>A_e</i> / <i>A_a</i>	0.305	0.25
<i>d_b</i> / <i>K_b</i>	2.03 m ² ·°C/W (11.4 (ft ² ·h·°F)/Btu)	1.32 m ² ·°C/W (7.5 (ft ² ·h·°F)/Btu)
<i>d_c</i> / <i>K_c</i>	2.33 × 10 ⁻⁵ m ² ·°C/W (1.32 × 10 ⁻⁴ (ft ² ·h·°F)/Btu)	9.8 × 10 ⁻⁶ m ² ·°C/W (5.6 × 10 ⁻⁵ (ft ² ·h·°F)/Btu)
<i>d_e</i> / <i>K_e</i>	0.342 m ² ·°C/W (1.94 (ft ² ·h·°F)/Btu)	0.658 m ² ·°C/W (3.74 (ft ² ·h·°F)/Btu)
<i>U_L</i> , back + <i>U_L</i> , edge	1.38 W/(m ² ·°C) (0.243 Btu/(ft ² ·h·°F))	1.14 W/(m ² ·°C) (0.201 Btu/(ft ² ·h·°F))

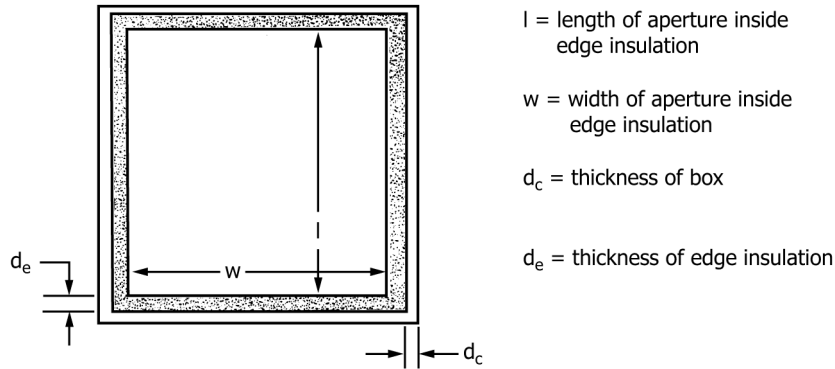
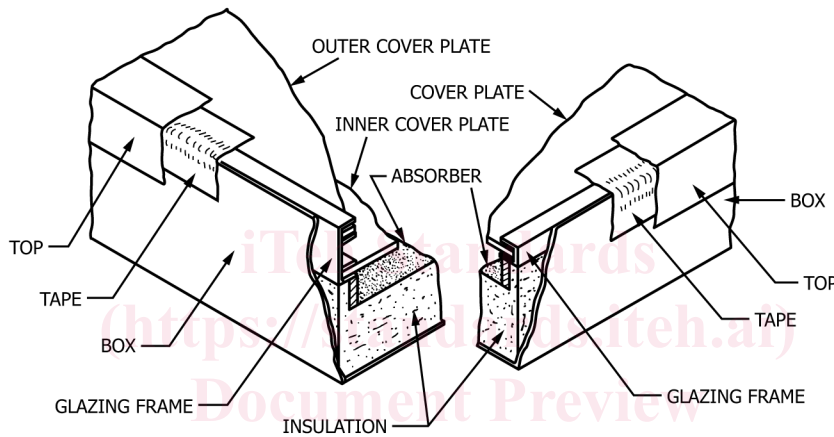

FIG. 1 Top View of Weathering Box Test Fixture

DOUBLE GLAZED

SINGLE GLAZED



Document Preview

ASTM E881-92(2015)

<https://standards.iteh.ai/catalog/standards/sist/615cced38a-913e-432c-824c-af58cfe/astm-e881-922015>

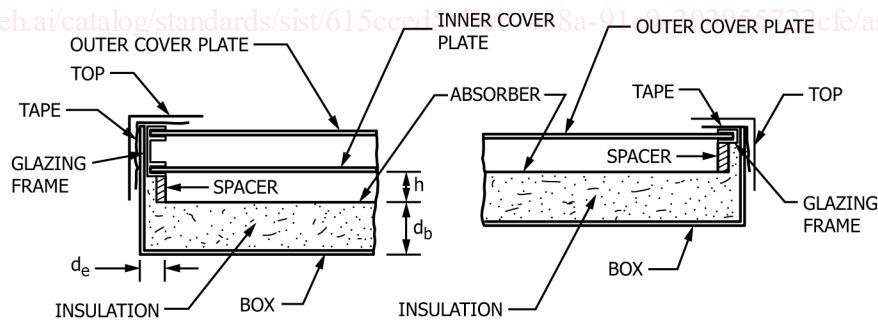

FIG. 2 Assembled Weathering Box Test Fixture

corrosion encountered in the environment would be suitable. If wood is used, it should be painted or treated on the exterior to make it resistant to moisture. In certain climates only rot-resistant wood should be used to minimize deterioration during exposure.

5.2.2 The insulation shall be a material suitable for use at a high temperature (for example, 150°C (302°F)).⁴

NOTE 3—Insulation materials having resins or binders should not be used because elevated temperatures may cause the resin or binder to deteriorate and outgas. Outgassing products condense on the cover material causing changes in the solar transmittance of the solar collector cover material.

5.2.3 The absorber shall be of an adequate size to cover the interior surface of the weathering box aperture. The absorber shall have a flat black nonselective coating having an absorptance not less than 0.90 after exposure.

5.2.4 The box top shall be of an adequate size to fit over the box.

NOTE 4—The box top is intended to protect the edges of the test specimen in contact with the box from reaching excessively high temperatures, to minimize exposure of the adhesive tape to sunlight, and to minimize moisture penetration into the exposure test fixture.

5.2.5 The glazing frame is intended to hold the cover plate material. The glazing frame shall have dimensions similar to the perimeter of the box. For a double-cover exposure the frame shall provide a separation between the two cover plates of not less than 13 mm (0.5 in.) or greater than 38 mm (1.5 in.). Exact dimensions of the frame are related to the requirements in 5.1.1. A vent hole may be drilled at one end of the glazing frame to provide drainage and to minimize moisture accumulation.

5.2.6 The spacer shall provide a separation of 13 to 38 mm (0.5 to 1.5 in.) between the absorber and the closest cover plate. Exact dimensions of the spacer are related to the requirements in 5.1.1.

NOTE 5—Certain designs of weathering boxes may eliminate the need for the spacer.

5.2.7 The adhesive tapes shall be stable when exposed to moisture and elevated temperatures. They shall be compatible with the specific materials from which the box, glazing frame, box top, and cover plate are made.

5.2.8 Organic materials are potential sources of outgassing and shall be eliminated from the interior of the weathering box where possible. For example, metallic parts shall be cleaned to remove traces of grease or other foreign matter. Other possible sources of outgassing include coatings and sealants. Test fixture components containing organic materials (for example, absorber coatings or insulation) shall be heated in an oven at 150°C (302°F) for 24 h before the test fixture is assembled. This should minimize outgassing that results from deterioration of the organic components exposed to elevated temperatures.

5.3 *Test Specimen:*

5.3.1 The test specimen shall be of an adequate size to cover the aperture of the box or glazing frame and to permit suitable attachment.

NOTE 6—Adequate allowances should be made for materials that will undergo dimensional changes due to temperature.

5.3.2 The test specimen identification marks shall not interfere with either the exposure or the subsequent testing.

5.4 *Sample Mounting:*

5.4.1 *Rigid and Semirigid Glazings:*

5.4.1.1 Lay the test specimen for single cover exposure directly on either the spacer or the glazing frames. If used, the frame is then placed on the spacer in the weathering box (see Fig. 2).

5.4.1.2 Lay the test specimen for inner cover exposure of a double cover assembly on the spacer or attach it to the glazing frame before the glazing frame is placed in the box (see Fig. 2).

5.4.1.3 Lay the test specimen for outer cover exposure of a double cover assembly on the top of the glazing frame (see Fig. 2).

5.4.2 *Films*—Place film test specimens on the glazing frame using adhesive transfer tape to hold the test specimen taut. It is essential that uniform tensioning be obtained prior to applying the tape. Then place the frame in the box similar to 5.4.1.1, 5.4.1.2, and 5.4.1.3.

5.5 *Assembly of Weathering Box:*

5.5.1 Slide the various parts of the weathering box test fixture into position. The outer glazing must be roughly flush with the top side of the box. The position of an inner glazing, if used, shall be nearest the bottom of the box.

5.5.2 After assembly, seal the frame and outer glazing in place with an adhesive tape to prevent moisture intrusion. Place the box top on the box (see Fig. 2).

6. Natural Weathering Exposure

6.1 Mount the weathering boxes in a backed condition using 13-mm (0.5-in.) exterior grade plywood on weathering racks such as those described in Practice D1435. The racks shall be capable of having the angles adjusted and have their axis of rotation on an east-west line.

6.2 Use a variable angle exposure to maximize solar radiation incident upon the weathering box. Adjust the racks according to the schedule given in Table 2. Positive rack angles face south. Choose the angles so that the weathering boxes are never closer to the horizontal than by 5°. Other variable exposure schedules requiring more than four adjustments per year may be used. The method for determining the variable angle exposure schedule is described in Appendix X2 of this practice.

TABLE 2 Variable-Angle Rack Adjustment Schedule Using Four Changes Per Year^{A,B}

Rack Tilt Angle, °	Calendar Period	
	Dates	Days of Year
Latitude ±2.5	3/2 to 4/11	61 to 101
Latitude – 16) ±2.5	4/12 to 8/31	102 to 243
Latitude ±2.5	9/1 to 10/10	244 to 283
(Latitude + 16) ±2.5	10/11 to 3/1	284 to 60

^A This exposure schedule may be used in both northern and southern hemispheres. The latitude in the southern hemisphere is negative. Positive rack angles face south.

^BThe incident angle of beam radiation (θ) at solar noon for a south-facing collector is $\leq 8^\circ$.

- 6.3 When a number of weathering boxes are exposed simultaneously, mount the boxes side by side with the sides not touching.
- 6.4 Do not clean the solar collector cover materials during exposure.
- 6.5 Visually inspect the test specimens at intervals of not more than one month. Record all changes in appearance.

7. Report

7.1 The report shall include the following:

- 7.1.1 Description of the weathering box test fixture and its calculated combined back and edge loss coefficient,
- 7.1.2 Whether the solar collector cover materials are exposed as a single- or double-cover configuration and whether the test specimen was the inner or outer cover,
- 7.1.3 Complete identification of the solar collector outer cover material(s),
- 7.1.4 Complete identification of the solar collector inner cover material(s) (if any),
- 7.1.5 A description of the test specimen attachment and mounting procedures,
- 7.1.6 Latitude, longitude, altitude, and address of the testing site including a description of the type of climate,

NOTE 7—Types of climate are described in Practice G7.

7.1.7 Exposure data:

- 7.1.7.1 Calendar dates of exposure and
- 7.1.7.2 Variable-angle rack adjustment schedule,

7.1.8 Climatological data:

- 7.1.8.1 Radiant energy (J/m^2) measured in the plane of the weathering boxes and
- 7.1.8.2 Monthly maximum, minimum, and mean temperatures,
- 7.1.9 A summary of the changes observed in the periodic visual inspections,
- 7.1.10 Description of control specimens, and
- 7.1.11 Any deviation from this practice.

7.2 Other data that are desirable to report, if available are:

7.2.1 Optional climatological data:

- 7.2.1.1 Daily maximum, minimum, and mean percent relative humidity,
- 7.2.1.2 Daily hours of wetness,
- 7.2.1.3 Daily total inches of rainfall,
- 7.2.1.4 Daily maximum and minimum ambient temperature,
- 7.2.1.5 Daily radiant energy, and
- 7.2.1.6 Wind direction and velocity.
- 7.2.2 Type of atmosphere, for example, industrial, and level of air pollutants,
- 7.2.3 Ultraviolet radiation, and
- 7.2.4 Maximum absorber plate temperature.

8. Precision and Bias

- 8.1 No information is presented about either the precision or bias of this test method, since the test result is non-quantitative.

9. Keywords

- 9.1 natural weathering; solar collector covers; stagnation; variable-angle exposure; weathering

APPENDIXES

(Nonmandatory Information)

X1. CALCULATION OF EXPOSURE TEST FIXTURE HEAT LOSSES

X1.1 Scope

X1.1.1 This appendix outlines the method for determining the combined back and edge loss coefficient for an exposure test fixture as referenced in 5.1.1 of this practice.

X1.2 Procedure

X1.2.1 *Assumptions:*

X1.2.1.1 One-dimensional heat transfer (neglect corner effects),

X1.2.1.2 The temperature of the outside surface of the box is equal to the ambient temperature, and

X1.2.1.3 The temperature of the inside surface of the edge insulation is equal to the absorber plate temperature. (A conservative assumption; the inside edge temperature would average less than the absorber plate temperature.)

X1.2.2 *Symbols:*

$Q_{loss, total}$	=	total heat loss of test fixture
$Q_{loss, back}$	=	heat loss of back of test fixture
$Q_{loss, top}$	=	heat loss of top of test fixture
$Q_{loss, edge}$	=	heat loss from the edges of test fixture
U_L	=	combined loss coefficient of back, edge, and top of test fixture
$U_{L,B}$	=	loss coefficient of back of test fixture
$U_{L,E}$	=	loss coefficient of edges of test fixture
$U_{L,T}$	=	loss coefficient of top of test fixture
h	=	distance from top of absorber to bottom of cover plate
l	=	length of aperture inside edge insulation
w	=	width of aperture inside edge insulation
A_a	=	area of aperture of test fixture
A_b	=	area of back insulation ($A_b = l \times w$)
A_e	=	area of edge insulation ($A_e = 2(l + w)h$)
d_b	=	thickness of back insulation
d_e	=	thickness of edge insulation
d_c	=	thickness of box
K_b	=	thermal conductivity of back insulation
K_e	=	thermal conductivity of edge insulation
K_c	=	thermal conductivity of box
T_p	=	temperature of absorber plate
T_a	=	temperature of ambient air
T_c	=	temperature of box

X1.2.3 *Heat Loss Coefficient Calculations:*

X1.2.3.1 *General Equations:*

ASTM E881-92(2015)
<https://standards.iteh.ai/catalog/standards/sist/615cced5-f5eb-458a-91e9-303955722cfe/astm-e881-922015>

$$Q_{loss, total} = Q_{loss, back} + Q_{loss, edge} + Q_{loss, top}, \text{ or} \tag{X1.1}$$

$$A_a U_L (T_p - T_a) = A_a U_{L,B} (T_p - T_a) \tag{X1.2}$$

$$+ A_a U_{L,E} (T_p - T_a) + A_a U_{L,T} (T_p - T_a)$$

where:
 all U_L values are referenced to aperture area, A_a .
 Dividing by $A_a(T_p - T_a)$,

$$U_L = U_{L,B} + U_{L,E} + U_{L,T} \tag{X1.3}$$

To keep different sizes of the test fixtures thermally equivalent, the sum of the loss coefficients, $U_{L,B}$, $U_{L,E}$, and $U_{L,T}$ must remain constant. The top loss coefficient can be held fairly constant by keeping the cover distance above the absorber plate between 13 and 38 mm (0.5 and 1.5 in.). With this constraint, the sum of the edge loss coefficient, $U_{L,E}$, and the back loss coefficient, $U_{L,B}$, must remain constant.

Therefore,

$$U_{L,B} + U_{L,E} = \text{constant} \tag{X1.4}$$

X1.2.3.2 *Determination of Heat Loss Coefficient ($U_{L,B}$) for Back of Test Fixture* —The heat loss through the back of a test fixture is equal to:

$$Q_{loss, back} = A_a U_{L,B} (T_p - T_a) \tag{X1.5}$$

$$= A_b (K_b / d_b) (T_p - T_c)$$

$$= A_b (K_c / d_c) (T_c - T_a)$$