



Designation: E681 – 09 (Reapproved 2015)

## Standard Test Method for Concentration Limits of Flammability of Chemicals (Vapors and Gases)<sup>1</sup>

This standard is issued under the fixed designation E681; the number immediately following the designation indicates the year of original adoption or, in the case of revision, the year of last revision. A number in parentheses indicates the year of last reapproval. A superscript epsilon ( $\epsilon$ ) indicates an editorial change since the last revision or reapproval.

### 1. Scope

1.1 This test method covers the determination of the lower and upper concentration limits of flammability of chemicals having sufficient vapor pressure to form flammable mixtures in air at atmospheric pressure at the test temperature. This test method may be used to determine these limits in the presence of inert dilution gases. No oxidant stronger than air should be used.

NOTE 1—The lower flammability limit (LFL) and upper flammability limit (UFL) are sometimes referred to as the lower explosive limit (LEL) and the upper explosive limit (UEL), respectively. However, since the terms LEL and UEL are also used to denote concentrations other than the limits defined in this test method, one must examine the definitions closely when LEL and UEL values are reported or used.

1.2 This test method is based on electrical ignition and visual observations of flame propagation. Users may experience problems if the flames are difficult to observe (for example, irregular propagation or insufficient luminescence in the visible spectrum), if the test material requires large ignition energy, or if the material has large quenching distances.

1.3 **Annex A1** provides a modified test method for materials (such as certain amines, halogenated materials, and the like) with large quenching distances which may be difficult to ignite.

1.4 In other situations where strong ignition sources (such as direct flame ignition) is considered credible, the use of a test method employing higher energy ignition source in a sufficiently large pressure chamber (analogous, for example, to the methods in Test Method **E2079** for measuring limiting oxygen concentration) may be more appropriate. In this case, expert advice may be necessary.

1.5 The flammability limits depend on the test temperature and pressure. This test method is limited to an initial pressure of the local ambient or less, with a practical lower pressure limit of approximately 13 kPa (100 mm Hg). The maximum practical operating temperature of this equipment is approximately 150°C.

<sup>1</sup> This test method is under the jurisdiction of ASTM Committee **E27** on Hazard Potential of Chemicals and is the direct responsibility of Subcommittee **E27.04** on Flammability and Ignitability of Chemicals.

Current edition approved Feb. 1, 2015. Published March 2015. Originally approved in 1979. Last previous edition approved in 2009 as E681 – 09. DOI: 10.1520/E0681-09R15.

1.6 The values stated in SI units are to be regarded as standard. No other units of measurement are included in this standard.

1.7 This test method should be used to measure and describe the properties of materials, products, or assemblies in response to heat and flame under controlled laboratory conditions and should not be used to describe or appraise the fire hazard or fire risk of materials, products, or assemblies under actual fire conditions. However, results of this test method may be used as elements of a fire risk assessment that takes into account all of the factors pertinent to an assessment of the fire hazard of a particular end use.

1.8 This standard may involve hazardous materials, operations, and equipment. *This standard does not purport to address all of the safety concerns, if any, associated with its use. It is the responsibility of the user of this standard to establish appropriate safety and health practices and determine the applicability of regulatory limitations prior to use.* Specific precautionary statements are given in Section 8

### 2. Referenced Documents

#### 2.1 ASTM Standards:<sup>2</sup>

**E171** Practice for Conditioning and Testing Flexible Barrier Packaging

**E582** Test Method for Minimum Ignition Energy and Quenching Distance in Gaseous Mixtures

**E1445** Terminology Relating to Hazard Potential of Chemicals

**E1515** Test Method for Minimum Explosible Concentration of Combustible Dusts

**E2079** Test Methods for Limiting Oxygen (Oxidant) Concentration in Gases and Vapors

#### 2.2 NFPA Standard:<sup>3</sup>

**NFPA 69** Standard on Explosion Prevention Systems

<sup>2</sup> For referenced ASTM standards, visit the ASTM website, [www.astm.org](http://www.astm.org), or contact ASTM Customer Service at [service@astm.org](mailto:service@astm.org). For *Annual Book of ASTM Standards* volume information, refer to the standard's Document Summary page on the ASTM website.

<sup>3</sup> Available from National Fire Protection Association (NFPA), 1 Batterymarch Park, Quincy, MA 02169-7471, <http://www.nfpa.org>.

### 3. Terminology

#### 3.1 Definitions:

3.1.1 *lower limit of flammability or lower flammable limit (LFL)*—the minimum concentration of a combustible substance that is capable of propagating a flame in a homogeneous mixture of the combustible and a gaseous oxidizer under the specified conditions of test.

3.1.2 *propagation of flame— as used in this test method*, the upward and outward movement of the flame front from the ignition source to the vessel walls or at least to within 13 mm (½ in.) of the wall, which is determined by visual observation. By outward, it is meant a flame front that has a horizontal component to the movement away from the ignition source.

3.1.3 *upper limit of flammability or upper flammable limit (UFL)*—the maximum concentration of a combustible substance that is capable of propagating a flame in a homogeneous mixture of the combustible and a gaseous oxidizer under the specified conditions of test.

3.2 Additional terms can be found in Terminology E1445.

### 4. Summary of Test Method

4.1 A uniform mixture of a gas or vapor with air is ignited in a closed vessel, and the upward and outward propagation of the flame away from the ignition source is noted by visual observation. The concentration of the flammable component is varied between trials until the composition that will just sustain propagation of the flame is determined.

### 5. Significance and Use

5.1 The LFL and UFL of gases and vapors define the range of flammable concentrations in air.

5.2 This method measures the LFL and UFL for upward (and partially outward) flame propagation. The limits for downward flame propagation are narrower.

5.3 Limits of flammability may be used to determine guidelines for the safe handling of volatile chemicals. They are used particularly in assessing ventilation requirements for the handling of gases and vapors. NFPA 69 provides guidance for the practical use of flammability limit data, including the appropriate safety margins to use.

5.4 As discussed in Brandes and Ural,<sup>4</sup> there is a fundamental difference between the ASTM and European methods for flammability determination. The ASTM methods aim to produce the best representation of flammability parameters, and rely upon the safety margins imposed by the application standards, such as NFPA 69. On the other hand, European test methods aim to result in a conservative representation of flammability parameters. For example, in this standard, LFL is the calculated average of the lowest go and highest no-go concentrations while the European test methods report the LFL as the minimum of the 5 highest no-go concentrations.

NOTE 2—For hydrocarbons, the break point between nonflammability

and flammability occurs over a narrow concentration range at the lower flammability limit, but the break point is less distinct at the upper limit. For materials found to be non-reproducible per 13.1.1 that are likely to have large quenching distances and may be difficult to ignite, such as ammonia and certain halogenated hydrocarbon, the lower and upper limits of these materials may both be less distinct. That is, a wider range exists between flammable and nonflammable concentrations (see Annex A1).

### 6. Interferences

6.1 This test method is not applicable to certain readily oxidized chemicals. If significant oxidation takes place when the vapors are mixed with air, unreliable results may be obtained. Flow systems designed to minimize hold-up time may be required for such materials.

6.2 Measured flammable limits are influenced by flame quenching effects of the test vessel walls. The test vessel employed in this test method is of sufficient size to eliminate the effects of the flame quenching for most materials (and conditions).

NOTE 3—There may be quenching effects, particularly on tests run at subambient pressures. For materials that may be difficult to ignite (see Note 2), tests in a larger vessel or different ignition sources (see Annex A1, 12-L flask) may show flame propagation that is not seen in the 5-L flask with spark or exploding wire igniters. This test method is a small scale test and this possible limitation must be considered in hazard assessments.

6.3 The oxygen concentration in the air has an important effect on the UFL. Typically, room air is used. If cylinder air is used to simulate room air it must have an oxygen concentration of  $20.94 \pm 0.1\%$ . Reconstituted air in cylinders has variability in the oxygen concentration and must be verified for oxygen concentration.

### 7. Apparatus

7.1 Fig. 1 is a schematic diagram of the apparatus; details and dimensions are presented in Appendix X1. The apparatus consists of a glass test vessel, an insulated chamber equipped with a source of controlled-temperature air, an ignition device with an appropriate power supply, a magnetic stirrer, and a cover equipped with the necessary operating connections and components.

7.2 If tests are to be conducted at an elevated temperature, the test vessel may be heated as described in Appendix X1. The heating system must be capable of controlling the gas temperature inside the test vessel to within  $\pm 3^\circ\text{C}$  both temporally and spatially. An appropriate device such as a thermocouple must be used to monitor the gas temperature within the test vessel. Active (connected) volumes beyond the test vessel itself should be held above the condensation temperature of all components in the material being tested. Electrical heating tapes must be employed for heating components to the desired temperature.

NOTE 4—Certain bare wire thermocouples may cause catalytic oxidation of test vapors, as evidenced by a persistent high-temperature excursion of the temperature reading. If this occurs, other thermocouple materials should be employed.

7.3 *Pressure Transducer*—A low-range pressure transducer may be used for the purpose of making partial pressure additions of gases and vapors to the test vessel. The transducer and its signal conditioning/amplifying electronics should have

<sup>4</sup> Brandes, E., and Erdem, A. U., "Towards a Global Standard for Flammability Determination," 42nd Annual Loss Prevention Symposium, New Orleans, LA, April 2008.

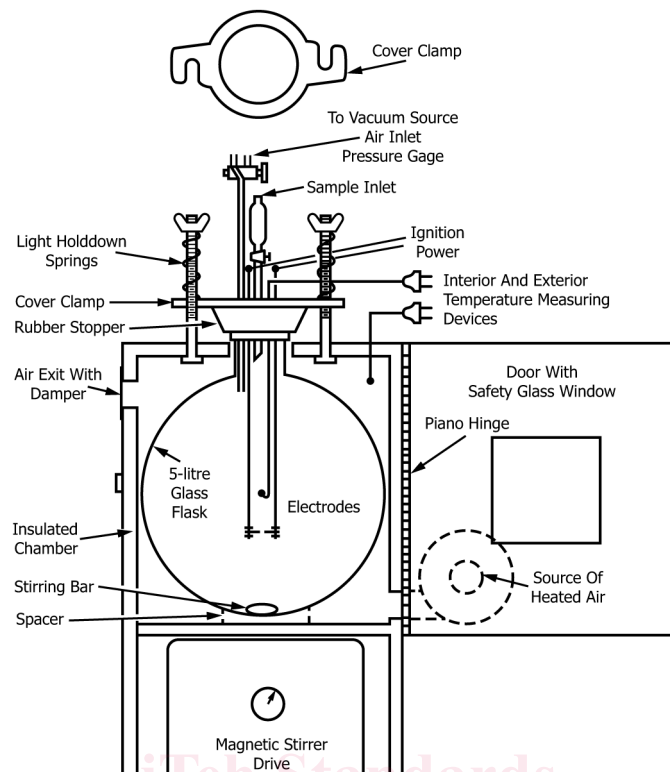

FIG. 1 Schematic Diagram of Test Apparatus

an accuracy, precision and repeatability sufficient to accurately resolve the required changes in the gas partial pressure for the component used in lowest concentration at the appropriate test temperature. The transducer should be protected from deflagration pressures by means of an isolation valve. An error analysis must be performed to demonstrate that the internal volume of the pressure gage and piping will not significantly affect the test mixture.

## 8. Safety Precautions

8.1 Tests should not be conducted in this apparatus with oxidizers stronger than air, since explosion violence increases as oxidizer strength increases. Do not use oxygen, nitrous oxide, nitrogen dioxide, chlorine, etc., in this glass apparatus. Extra care must be used when working with compounds that are potential oxidizers.

8.2 Adequate shielding must be provided to prevent injury in the event of equipment rupture due to both implosions and explosions. A metal enclosure, such as that recommended in [Appendix X1](#), is one method suitable for this purpose.

8.2.1 Implosion of the test vessel at high vacuum levels is possible; therefore, all evacuations must be made with the required shielding to protect against flying fragments.

8.2.2 Energetic explosions may be produced if tests are made at concentrations within the flammable range, between the LFL and UFL. The glass test vessel, equipped with a lightly held or loose cover, vents most explosions adequately. Nevertheless, shielding is required to protect against vessel

rupture. Methods for estimating initial test concentrations, discussed in [Appendix X2](#), [Appendix X3](#), and [Appendix X4](#), may be employed to ensure that initial trials are conducted at concentrations less than the LFL or greater than the UFL.

8.2.3 In rare instances, particularly in the upper limit tests, self-ignition may be encountered when air is rapidly introduced into the partially evacuated test vessel containing the vaporized sample. Valves permitting remote operation, changes in sample and air introduction sequences, simple shields, and other techniques may be employed to ensure safe operations.

8.2.4 The test area should be equipped with electrical interlocks to prevent activation of the ignition source unless adequate shielding is in place.

8.3 Tests should not be conducted on thermally unstable materials that might undergo explosive decomposition reactions.

8.4 Tests should be conducted in a fume hood or other ventilated area to prevent personal exposure to toxic chemicals or combustion products.

8.5 Precautions must be taken to ensure that the high-voltage spark ignition source does not contact temperature or pressure-measuring devices or other conductive paths that could create an electrical hazard to personnel or instrumentation outside the shielded area. Careful attention to electrical insulation integrity can reduce the possibility of hazard. Disconnects for all instrumentation lines will provide positive protection.

## 9. Calibration

9.1 Accurate determination of the flask volume is necessary for the calculation of flammable limits when the sample measurement is on a weight or volume basis.

9.1.1 Determine the total volume of the flask as follows: Weigh a clean, dry flask with all components installed. Fill the flask with distilled water. Reinsert the cover, allowing the excess water to overflow, dry the outside of the flask, and reweigh. Record the difference in grams as the net volume of the flask in cubic centimeters. (Slight errors associated with water density differences are beyond the accuracy of this test method.)

9.2 Calibrate pressure-, temperature-, and liquid-measuring devices against adequate standards.

## 10. Procedure

10.1 Assemble the equipment, as shown in Fig. 1, using an appropriate fume hood or other ventilated area, and secure the door of the metal enclosure. The test vessel and all components should be clean and dry. Evacuate the system and flush with air to ensure removal of residual volatile materials that may be present as a result of cleaning or prior tests. As many as three evacuation/flush cycles may be required to ensure complete removal of combustion products between tests.

10.2 Adjust the flask to the desired test temperature. This temperature must be above the vapor condensation temperature of the mixture being tested.

10.2.1 When working at elevated temperatures and with materials that can condense at room temperature, it may be necessary to heat or insulate cover components and feed lines separately to prevent vapor condensation.

10.3 Record the actual barometric pressure at the test location.

10.4 Double-check to make certain that all safety precautions have been taken.

### 10.5 Procedure for Sample Introduction As a Liquid:

10.5.1 Ensure that sample and any combustion products from previous runs have been removed. This may be accomplished by evacuating the flask to a pressure of less than 2.7 kPa (20 mm Hg).

10.5.2 Place the desired liquid volume in a hypodermic syringe of appropriate size. Liquid volumes for initial trials may be estimated by methods given in Appendix X2. Transfer the liquid to the inlet separatory funnel (see 10.5.4.1).

10.5.3 Turn on the stirrer at a minimum speed of 400 rpm. A lower speed is adequate if the optional propeller mixer is used (see Fig. 2).

10.5.4 Open the inlet stopcock. Allow the sample to be drawn into the flask. Close the stopcock when all the liquid has entered. Place a cover on the inlet separatory funnel.

10.5.4.1 A serum-bottle septum may be used in place of the separatory funnel. In this case, inject the sample directly into the flask by piercing the septum with the hypodermic needle. It will be necessary to make a volume correction if a significant volume of liquid is drawn from the needle or uncalibrated portion of the syringe.

10.5.5 When sample vaporization is complete, remove the separatory funnel cover and open the stopcock, permitting air to enter the test vessel slowly through the separatory funnel (see 8.2.3). Entering air sweeps traces of residual sample into the flask.

10.5.6 Release the cover hold-down, and close the hood door.

10.5.7 Continue stirring for at least 5 min to obtain complete mixing and attainment of thermal equilibrium. Final trials should be made at longer mixing times to ensure optimal mixing conditions are achieved.

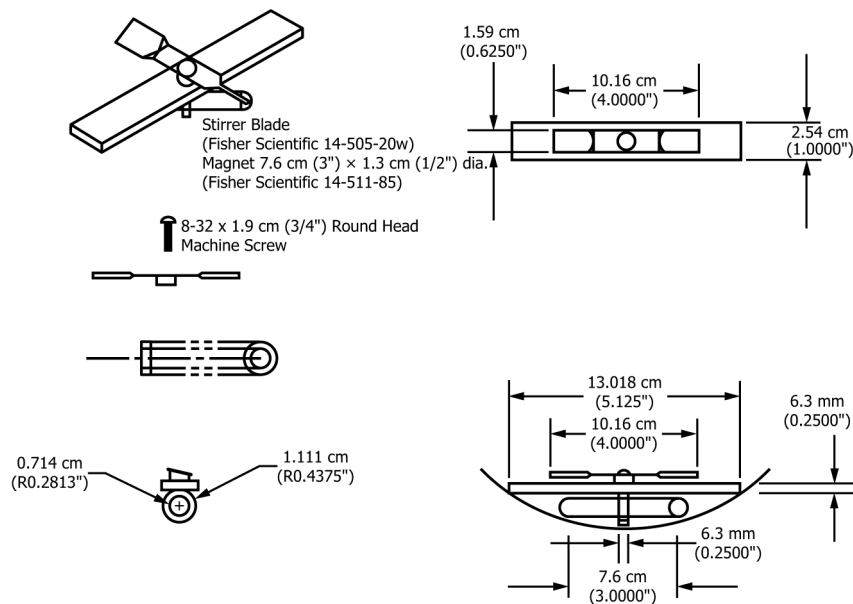

FIG. 2 Magnetic Driven Stirrer

10.5.8 Turn off the stirrer.

10.5.9 Record the test temperature,  $T$ .

10.5.10 Disconnect instrumentation lines as required.

10.5.11 Darken the viewing area. Activate the ignition source. Observe for ignition and flame propagation away from the ignition source. See 3.1.2 for definition of flame propagation. A limit determining concentration is called nonflammable only if it cannot be ignited after at least one repetition of the measurement (see 10.5.1 – 10.5.11).

NOTE 5—Mixtures having a composition just outside the flammable range exhibit a small cap of flame above the igniter position; in some cases, a vertical streak of flame may propagate to the vessel cover. (Absence of a flame cap may be an indication of insufficient ignition energy.) The onset of upward and partial outward flame propagation signifies a limit or near-limit mixture. It is suggested that detailed observation of flame behavior be recorded on all trials. Include such notes as flame cap,<sup>5</sup> upward and outward propagation, downward propagation, etc. These observations can serve as a guide to narrowing the region of uncertainty between go and no-go trials.

10.5.12 Vary sample size as required to find the minimum sample size,  $L_1$ , that gives flame propagation and the maximum sample size,  $L_2$ , below  $L_1$ , that does not give flame propagation. (The difference between  $L_1$  and  $L_2$  is a measure of the variability of the procedure for the material being studied.)

10.5.13 If numerous trials are required for a given series of tests, it may be necessary to remove the vessel for cleaning periodically, particularly for upper limit studies.

10.5.14 Final trials shall be made in a clean vessel.

NOTE 6—Ignition failures and inconsistent performance are occasionally encountered, for example, when high dielectric strength or very high ignition energy materials are tested using a spark ignition source. Limits for these materials should be determined using a fuse wire ignition source. Fuse wire ignition should also be used to confirm reduced pressure limit values arrived at on the basis of spark ignition source trials. Good electrical contacts in the circuit of the fused wire are indicated by complete vaporization of the copper wire. If complete vaporization is not accomplished, the ignition trial should be disregarded (unless it was a propagation). The ignition trial should be repeated after ensuring that good electrical contacts have been established in the fused wire circuit.

10.5.15 Record the values of the sample volume  $L_1$  and  $L_2$ . If partial propagation occurs over a range of sample sizes greater than 10 % of the sample size, the range should be specified in the report, for example, LFL =  $5.4 \pm 0.6$  %.

10.5.16 Commence upper limit tests at a concentration greater than  $U_2$ , as defined in 10.5.17. Sample size for initial trial may be determined by methods given in Appendix X3.

10.5.17 Record the values for the greatest sample quantity  $U_1$  that will propagate a flame, and the least quantity  $U_2$  above  $U_1$  that will not propagate a flame.

## 10.6 Procedure for Sample Introduction As a Vapor:

10.6.1 Sample concentrations can be measured for gases and readily vaporized liquids on the basis of partial pressure. In these instances, equip the vessel with a pressure transducer capable of reading to the nearest 0.07 kPa (0.5 mm Hg) or 1 % for the reading, whichever is larger. The system must also be capable of maintaining a vacuum of 0.067 kPa (0.5 mm Hg), or less.

10.6.2 Evacuate vessel and sample lines to a pressure of 1.33 kPa (10.0 mm Hg, or less). Ensure that the samples and the products of previous combustions have been removed.

NOTE 7—The vessel must not leak, isolated under vacuum, more than 0.1 kPa (1 mm Hg) /min.

10.6.3 Introduce the sample as a vapor through an appropriate inlet valve until the desired pressure is achieved. Introduce air as in 10.5.5, raising the pressure to atmospheric.

10.6.4 Carry out 10.5.6 – 10.5.17 as needed.

## 10.7 Procedure for Sample Introduction As a Solid:

10.7.1 Chemicals with melting points above room temperature but that totally melt and vaporize or totally sublime at the test conditions may be added to the test vessel as solids.

10.7.2 Bring the test vessel to atmospheric pressure. (Prior evacuation must be employed, as in 10.1, to ensure cleanliness.)

10.7.3 Place the desired sample weight in the flask by raising the cover and inserting the sample.

10.7.4 Carry out 10.5.6 – 10.5.17 as needed.

NOTE 8—A small portion of the sample may be lost from the test vessel as the sample vaporizes and warms up to the test temperature. Losses are minimized by delaying the start of stirring until vaporization is complete. Maximum theoretical sample loss, which is small, may be readily calculated.

## 11. Calculation

11.1 Calculate the sample quantity,  $L$  or  $U$ , as follows:

$$L = \frac{1}{2}(L_1 + L_2) \quad (1)$$

$$U = \frac{1}{2}(U_1 + U_2) \quad (2)$$

where:

$L$  = sample quantity used to calculate the LFL by Eq 3, and  
 $U$  = sample quantity used to calculate the UFL by Eq 3.

11.1.1 For  $L_1$  and  $L_2$ , see 10.5.12. For  $U_1$  and  $U_2$ , see 10.5.17.

11.2 Calculate the LFL and UFL from the sample quantities. Ideal vapor phase behavior is assumed. (See X5.2 for a sample calculation and X5.1 for development of Eq 3.)

11.2.1 *Liquid Samples (Ideal Vapor Phase Behavior Is Assumed):*

$$\text{LFL} = \frac{(L_v)(d)(T)}{(\text{MW})(P)} \times \frac{(V_o)(P_o)(100\%)}{(V)(T_o)} \quad (3)$$

where:

$V$  = volume of flask, L,  
 LFL = lower flammable limit, mol or volume, %,  
 $L_v$  =  $L$  = sample volume from Eq 1,  $\text{cm}^3$ ,  
 $d$  = sample density,  $\text{g}/\text{cm}^3$ ,  
 $T$  = test temperature,  $K$ ,  
 MW = sample molecular weight, g, and  
 $P$  = test pressure, absolute, kPa (mm Hg).

11.2.1.1 The second term is a constant for a given test apparatus where  $P_o$  = standard pressure 101.3 kPa (760 mm Hg) or desired pressure  $V_o$  = volume of 1 mol of material at  $P_o$

<sup>5</sup> Coward, H. F., and Jones, G. W., "Limits of Flammability of Gases and Vapors," Bulletin 503 Bureau of Mines, 1952, p. 1.

and  $T_o$ , and  $T_o$  = standard or test temperature (273 K). (Any set of consistent units may be used for these calculations.)

11.2.1.2 Calculate UFL by replacing LFL with UFL and  $L_v$  with  $U_v$  in Eq 3.

11.2.2 *Vapor Samples (Ideal Vapor Phase Behavior Is Assumed)*:

$$\text{LFL} = (L_p/P) \times 100\% \quad (4)$$

where:

$L_p$  =  $L$  = sample partial pressure kPa (mm Hg) from Eq 1.

11.2.2.1 Calculate UFL by replacing LFL with UFL and  $L_p$  with  $U_p$ ,  $U_p = U$  = sample partial pressure kPa (mm Hg) from Eq 1.

11.2.3 *Solid Samples (Ideal Vapor Phase Behavior Is Assumed)*:

11.2.3.1 Calculate LFL by using Eq 3 with the terms  $L_p$  ( $d$ ) replaced by  $L_w$ , where  $L_w = L$  = sample weight (g) from Eq 1.

11.2.3.2 Calculate UFL by replacing LFL with UFL and  $L_w$  with  $U_w$ .

11.3 *Complex Liquids, Solids, and Mixtures*—Flammability limits of some materials cannot be calculated in terms of moles or volume % (see Eq 3), since the molecular weight of the vapors is not known. This occurs in the case of unknown materials, multicomponent mixtures, and materials exhibiting nonideal vapor phase behavior. It is more meaningful to express these limits in terms of weight of combustible per unit volume for mixture  $\text{g/m}^3$ .

NOTE 9—Such limits are often given in the literature<sup>6</sup> (also see Test Methods E1515 and E582) as weight of combustible per volume of air at standard conditions (0°C and 101 kPa, which equals 760 mm Hg). These limits may be calculated from the following expression or by a similar expression for UFL:

$$\text{LFL, g/m}^3 = \frac{\text{LFL}(\text{volume \%})}{\left(100 - \text{LFL}(\text{volume \%}) \left(\frac{0.0224}{\text{MW}}\right)\right)} \quad (5)$$

11.3.1 Calculate LFL of mixed vapors and materials exhibiting nonideal vapor phase behavior as follows:

<sup>6</sup> Lunn, G. A., "A Note on the Lower Explosibility Limit of Organic Dust," *Journal of Hazardous Material*, Vol 16, 1988, pp. 207–213.

$$\text{LFL}_w = \frac{L_w}{V} \text{ or } \frac{L_v(d)}{V} \quad (6)$$

where:

$L_w$  = weight of sample, mg, and

$\text{LFL}_w$  = LFL, mg/L.

11.3.2 Calculate UFL using Eq 6 replacing  $\text{LFL}_w$  with  $\text{UFL}_w$ ,  $L_w$  with  $U_w$ , and  $L_v$  with  $U_v$ .

## 12. Report

12.1 Report flammability limits, LFL and UFL, calculated in accordance with Eq 3, Eq 4, or Eq 6, along with the test temperature, test pressure, and ignition source (spark or fuse wire) used.

12.2 Report the limits initially in accordance with the units of measurement used in the determinations, that is, on a volumetric basis (mole or volume %) for gases or vapor samples and on a gravimetric basis (milligrams per litre) for liquid or solid samples.

12.3 By substitution in Eq 3, calculated limits may then also be given for gases or vapors on a gravimetric basis and for liquids or solids on a volumetric basis, provided molecular weights of the combustibles are known. The report shall note if nonideal vapor phase behavior is suspected or known to occur.

12.4 Report the test variability if it exceeds 10 % of the sample size (see 13.1.1).

## 13. Precision and Bias

### 13.1 Precision:

13.1.1 Repeatability for a hydrocarbon such as pentane within a single laboratory for this test method is 0.1 volume % for the LFL and 0.15 volume % for the UFL. Reproducibility for a hydrocarbon such as pentane between labs for this test method is 0.1 volume % for the LFL and 0.9 volume % for the UFL.

13.2 *Bias*—Since there is no acceptable reference material suitable for determining the bias for the procedure in this test method for measuring the concentration limits of flammability of chemicals, bias has not been determined.

## ANNEX

### (Mandatory Information)

#### A1. TEST METHOD FOR MATERIALS WITH LARGE QUENCHING DISTANCES, WHICH MAY BE DIFFICULT TO IGNITE

##### A1.1 Scope

A1.1.1 Materials that may have large quenching distances need special precautions to ensure identification of the full flammable range. These difficult-to-ignite materials, such as ammonia and certain halogenated hydrocarbons, have UFL and LFL that may be less distinct than those of hydrocarbons.

##### A1.2 Terminology

###### A1.2.1 Definition:

A1.2.1.1 *flame propagation*—The less-distinct flammability limits of these materials require more specific criteria for flame propagation. Flame propagation is defined as flames that having spread upward and outward to the walls of the flask, are