



Designation: E1084 – 86 (Reapproved 2015)

# Standard Test Method for Solar Transmittance (Terrestrial) of Sheet Materials Using Sunlight<sup>1</sup>

This standard is issued under the fixed designation E1084; the number immediately following the designation indicates the year of original adoption or, in the case of revision, the year of last revision. A number in parentheses indicates the year of last reapproval. A superscript epsilon ( $\epsilon$ ) indicates an editorial change since the last revision or reapproval.

## 1. Scope

1.1 This test method covers the measurement of solar transmittance (terrestrial) of materials in sheet form by using a pyranometer, an enclosure, and the sun as the energy source.

1.2 This test method also allows measurement of solar transmittance at angles other than normal incidence.

1.3 This test method is applicable to sheet materials that are transparent, translucent, textured, or patterned.

1.4 *This standard does not purport to address all of the safety concerns, if any, associated with its use. It is the responsibility of the user of this standard to establish appropriate safety, health, and environmental practices and determine the applicability of regulatory limitations prior to use.*

1.5 *This international standard was developed in accordance with internationally recognized principles on standardization established in the Decision on Principles for the Development of International Standards, Guides and Recommendations issued by the World Trade Organization Technical Barriers to Trade (TBT) Committee.*

## 2. Terminology

### 2.1 Definitions:

2.1.1 *pyranometer, n*—a radiometer used to measure the total solar radiant energy incident upon a surface per unit time per unit area. This energy includes the direct radiant energy, diffuse radiant energy, and reflected radiant energy from the background.

2.1.2 *solar reflectance, n*—the ratio of reflected to incident solar flux.

2.1.3 *solar transmittance, n*—the ratio of transmitted to incident solar flux.

### 2.2 Definitions of Terms Specific to This Standard:

2.2.1 *solar flux, n*—the total radiation from the sun, both direct and diffuse.

<sup>1</sup> This test method is under the jurisdiction of ASTM Committee E44 on Solar, Geothermal and Other Alternative Energy Sources and is the direct responsibility of Subcommittee E44.20 on Optical Materials for Solar Applications.

Current edition approved March 1, 2015. Published April 2015. Originally approved in 1986. Last previous edition approved in 2009 as E1084 – 86 (2009). DOI: 10.1520/E1084-86R15.

## 3. Summary of Test Method

3.1 Using a pyranometer to measure the solar irradiance, the test specimen is inserted in the path of the rays from the sun to the pyranometer. An enclosure with a nonreflecting bottom is used to avoid measuring flux from around the edges of the specimen or from multiple reflections between the box and the specimen. The transmittance is the ratio of the flux measured with the specimen in the light path to the flux measured without the specimen in the path.

## 4. Significance and Use

4.1 Solar transmittance is an important factor in the admission of energy through fenestration, collector glazing, and protective envelopes. This test method provides a means of measuring this factor under fixed conditions. While the data may be of assistance to designers in the selection and specification of glazing materials, the solar transmittance is not sufficient to define the rate of net heat transfer without information on other important factors.

4.2 This test method has been found practical for both transparent and translucent materials, as well as for those with transmittance reduced by highly reflective coatings. This test method is particularly applicable to the measurement of transmittance of inhomogeneous, fiber reinforced, patterned, or corrugated materials since the transmittance is averaged over a large area.

4.3 This test method may be used to measure transmittance of glazing materials at angles up to 60° off normal incidence.

NOTE 1—A technique similar to the one described but using a pyrhelimeter has been used for the measurement of specular solar reflectance; however, there is insufficient experience with this technique for standardization at present.

## 5. Apparatus

5.1 *Enclosure*—The required apparatus is a box capable of supporting a 0.60 m (24 in.) square specimen. The box shall have a square, clear aperture of no less than 0.50 m by 0.50 m (20 in. by 20 in.). The enclosure shall have provisions to hold specimens planar across the aperture with the additional capability to remove and replace the specimen easily during the measurement process. It shall also have the capability to move the specimen across the aperture in a systematic way. Light

baffled air vents at the top and bottom of the enclosure are recommended to aid cooling of all components when a specimen is in place. The inside of the box shall have side walls covered with mirrors having specular, solar reflectance greater than 0.85 that extend from the opening down to the plane of the sensor element. The rest of the inside of the box shall be blackened so that its solar reflectance is less than 0.10. A typical unit is shown in Fig. 1.

NOTE 2—Mirrors having the necessary specular reflectance are bright anodized aluminum lighting sheet, aluminized polymer films, and conventionally mirrored glass. For highly diffusing materials, a box with the specified aperture and blackened side walls, the test method could underestimate the transmittance by up to 0.03. Using highly reflecting side walls on the interior of the enclosure reduces this error for such materials to less than 0.01 transmittance unit. For highly specular materials, this error is negligible.

NOTE 3—For an enclosure with a highly reflecting bottom, the

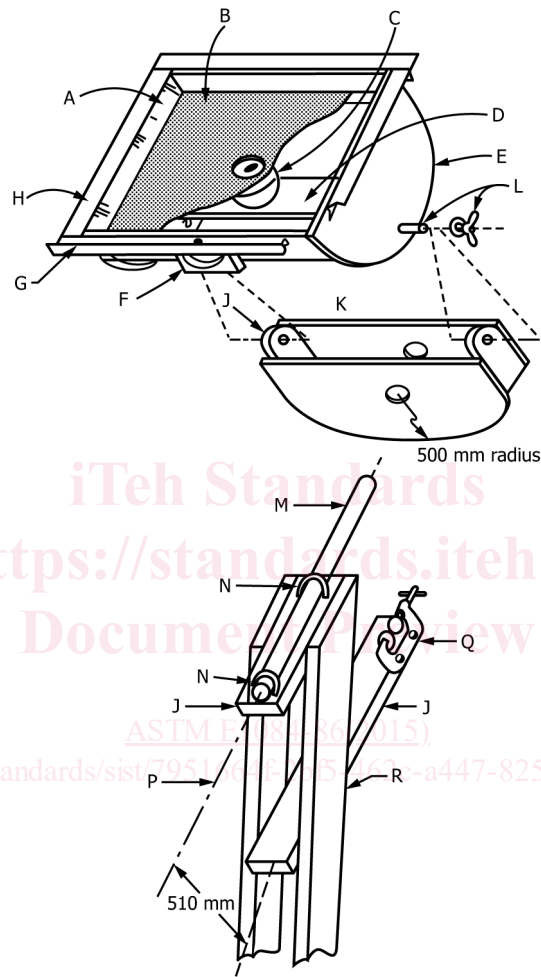

- (A) Specular mirror, 500 × 50 mm.
- (B) Nonreflecting, black bottom. Nontransmitting louvers or multiple layers of grill cloth that allow air circulation into the enclosure are preferable.
- (C) Pyranometer
- (D) Support shelf for pyranometer. The height of the shelf will depend on the pyranometer used.
- (E) Semicircular disk 538 mm diameter out of ¾ in. plywood.
- (F) Semicircular tracker with scale
- (G) Lip of flange turned up to 20 mm to help support specimens
- (H) 50 mm flange bent out of sheet metal or cut from wood. Top surface is painted back to prevent light entering enclosure due to multiple reflections from around the specimen edges.
- (J) Standard 2 × 4 in. wood framing, 75 mm long (bottom to center of hole)
- (K) Rectangular, ¾ in. plywood, 500 × 75 mm.
- (L) ½ × 2 in. carriage bolt with wing and washer.
- (M) ¾ in. iron pipe.
- (N) U-bolts.
- (P) Primary tracking axis, aligned parallel to earth's axis of rotation. The axis shall make an angle with the vertical equal to the local latitude and point toward the North Star.
- (Q) C-clamp attached to arm to lock equatorial angle during measurements.
- (R) Vertical support post approximately 1 m long. Made from standard 2 × 6 ft lumber.

NOTE 1—This apparatus consisting of enclosure, detector, and equatorial mount has been found acceptable for measuring solar transmittance of sheet materials. The majority of the pieces are cut from standard 2.4, 2 by 6, and ¾ in. plywood construction materials.

**FIG. 1 Apparatus Consisting of Enclosure, Detector, and Equatorial Mount**

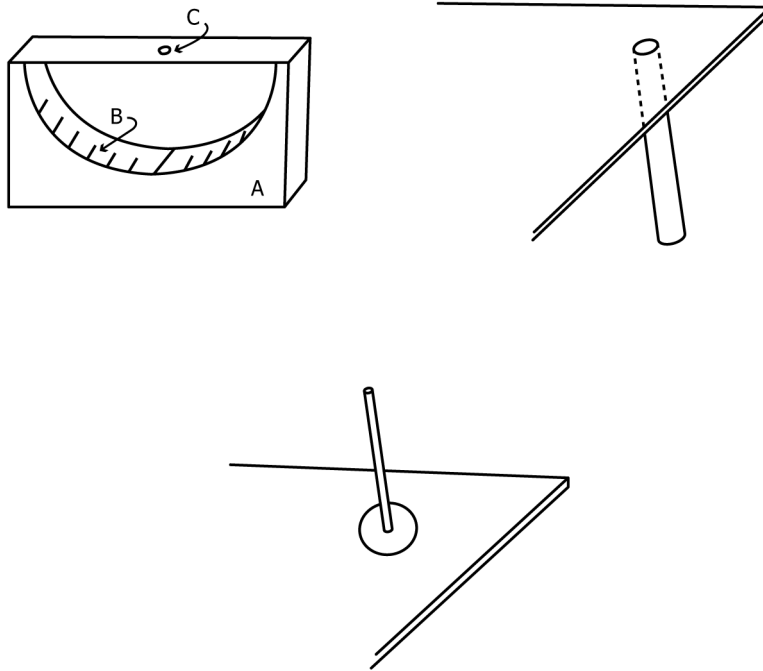

(a) Semicircle with scale

(A) Semicircle with 143 mm radius cut out of 150 300 mm piece of  $\frac{1}{2}$  to  $\frac{3}{4}$  in. plywood.

(B) Tape with 1 cm scale attached to inside of semicircle.

(C) This opaque sheet (preferably metal) with 3 mm aperture centered above semicircle.

Note—A displacement of the light beam coming through the aperture of 1 cm on the circumference of the semicircle equals  $4^\circ$  misalignment. This tracker is convenient for determining angles for off normal incidence measurements.

(c) 9 mm diameter rod by 500 mm long centered on 80 mm diameter white disk.

Note—Realign when shadow of rod falls outside of white disk.

NOTE 1—The dimensions are chosen to provide  $\pm 4^\circ$  limits on deviations from normal to the sun. In (b) and (c) care must be taken to mount the rod or pipe perpendicular to the surface of the enclosure.

FIG. 2 Alignment Devices for Enclosure

measured transmittance could be greater than 0.05 too high due to multiple reflections. A blackened bottom having less than 0.10 reflectance will hold this error to less than 0.005 transmittance units.<sup>2</sup>

### 5.2 Tracking:

5.2.1 The enclosure shall be mounted in a manner that allows repositioning approximately every 15 min in order to track the sun. The use of an equatorial or altazimuth mount is recommended and automatic solar tracker is optional.

5.2.2 For manual tracking, an alignment device shall be used. Several acceptable devices are shown in Fig. 2.

### 5.3 Sensor:

5.3.1 The sensing element of this apparatus is a pyranometer that shall meet WMO Class 2 specifications (1, 2).<sup>3</sup> The most important characteristics for the pyranometer are as follows:

5.3.1.1 a flat spectral sensitivity ( $\pm 2\%$ ) over the region from 300 nm to 3000 nm that encompasses nearly all the terrestrial solar flux;

5.3.1.2 sensitivity that is isotropic except for the usual cosine response with altitude angle; and

5.3.1.3 output linear to within  $\pm 2\%$  from 0 to 1000 W/m<sup>2</sup> or calibration curves accurate to within  $\pm 2\%$  over the same range. Additional desirable characteristics are relative short-time constants of a few seconds and good temperature stability.

NOTE 4—When using pyranometers meeting WMO Class 2 specifications in this procedure, the inaccuracies due to these sources are expected to be less than 1%. This is because relative, rather than absolute, readings are made over a dynamic range that is small compared to the range of the sensor. The procedure and apparatus specified in this test method minimize the thermal drift during the measurements.

5.3.2 The pyranometer shall be located so that the sensing thermopile (not the dome) is centered approximately 50 mm (2 in.) below the plane of the rim of the box. Normally pyranometers have a  $180^\circ$  viewing angle, but when placed as described, the field angle to the midpoint of the edges of the test specimen is  $157^\circ$ .

5.3.3 For pyranometers with thermal control shields having high reflectance, for example, the Eppley P.S.P.) it is important that the reflection from the pyranometer back toward the sheet material under test be minimized. This can be done by covering

<sup>2</sup> Flat black paints are satisfactory for this purpose. Also, a lining of opaque black velvet cloth such as that available from photographic suppliers is suitable.

<sup>3</sup> The boldface numbers in parentheses refer to the list of references at the end of this standard.