



Designation: C1242 – 15

Standard Guide for Selection, Design, and Installation of Dimension Stone Attachment Systems¹

This standard is issued under the fixed designation C1242; the number immediately following the designation indicates the year of original adoption or, in the case of revision, the year of last revision. A number in parentheses indicates the year of last reapproval. A superscript epsilon (ϵ) indicates an editorial change since the last revision or reapproval.

INTRODUCTION

Natural building stone is chosen as a building's cladding for its beauty which endures with minimal maintenance. Stone is durable when used properly. Exercising good judgment when selecting the particular stone, determining the quarrying and fabrication techniques, designing the method of attachment, and installing all components correctly maximizes these benefits. A properly executed stone cladding is designed and installed within the capabilities and limitations of the stone and support system to resist all forces that work on them.

This guide presents design principles that require consideration when designing anchorages and evaluating exterior stone to be compatible with its proposed use. It is an overview of current techniques and a review of minimum requirements for sound stone engineering and construction. The guide does not list all possible methods of attachment nor does it provide a step-by-step procedure for stone anchor engineering. Knowledge gained from new engineering designs, testing of applications, and the investigation of existing problems are continually reviewed to update this guide. Comment from users is encouraged.

Good judgment by architects, engineers, and contractors when specifying, designing, engineering, and constructing stone and other work that interfaces stone is necessary to use this guide. Users of this guide should combine known performance characteristics of the stone, the building's structural behavior, and knowledge of materials and construction methods with proven engineering practice.

1. Scope

1.1 This guide covers the categories of anchors and anchoring systems and discusses the design principles to be considered in selecting anchors or systems that will resist gravity loads and applied loads.

1.2 This guide sets forth basic requirements for the design of stone anchorage and provides a practical checklist of those design considerations.

1.3 This guide pertains to:

¹ This guide is under the jurisdiction of ASTM Committee C18 on Dimension Stone and is the direct responsibility of Subcommittee C18.06 on Attachment Components and Systems.

Current edition approved March 1, 2015. Published April 2015. Originally approved in 1993. Last previous edition approved in 2014 as C1242 – 14a. DOI: 10.1520/C1242-14A.

1.3.1 The anchoring of stone panels directly to the building structure for support,

1.3.2 The anchoring of stone panels to subframes or to curtainwall components after these support systems are attached to the building structure,

1.3.3 The anchoring of stone panels to subframes or to curtainwall components with stone cladding preassembled before these support systems are attached to the building structure, and

1.3.4 The supervision and inspection of fabrication and installation of the above.

1.4 Observe all applicable regulations, specific recommendations of the manufacturers, and standards governing interfacing work.

1.5 The values stated in inch-pound units are to be regarded as standard. The values given in parentheses are mathematical

conversions to SI units that are provided for information only and are not considered standard.

1.6 This standard does not purport to address all of the safety concerns, if any, associated with its use. It is the responsibility of the user of this standard to establish appropriate safety and health practices and determine the applicability of regulatory limitations prior to use. (See Tables 1 and 2.)

2. Referenced Documents

2.1 ASTM Standards:²

- C97 Test Methods for Absorption and Bulk Specific Gravity of Dimension Stone
- C99 Test Method for Modulus of Rupture of Dimension Stone

- C119 Terminology Relating to Dimension Stone
- C170 Test Method for Compressive Strength of Dimension Stone
- C406 Specification for Roofing Slate
- C482 Test Method for Bond Strength of Ceramic Tile to Portland Cement Paste
- C503 Specification for Marble Dimension Stone
- C509 Specification for Elastomeric Cellular Preformed Gasket and Sealing Material
- C568 Specification for Limestone Dimension Stone
- C615 Specification for Granite Dimension Stone
- C616 Specification for Quartz-Based Dimension Stone
- C629 Specification for Slate Dimension Stone
- C864 Specification for Dense Elastomeric Compression Seal Gaskets, Setting Blocks, and Spacers
- C880 Test Method for Flexural Strength of Dimension Stone
- C920 Specification for Elastomeric Joint Sealants
- C1115 Specification for Dense Elastomeric Silicone Rubber Gaskets and Accessories
- C1193 Guide for Use of Joint Sealants

²For referenced ASTM standards, visit the ASTM website, www.astm.org, or contact ASTM Customer Service at service@astm.org. For Annual Book of ASTM Standards volume information, refer to the standard’s Document Summary page on the ASTM website.

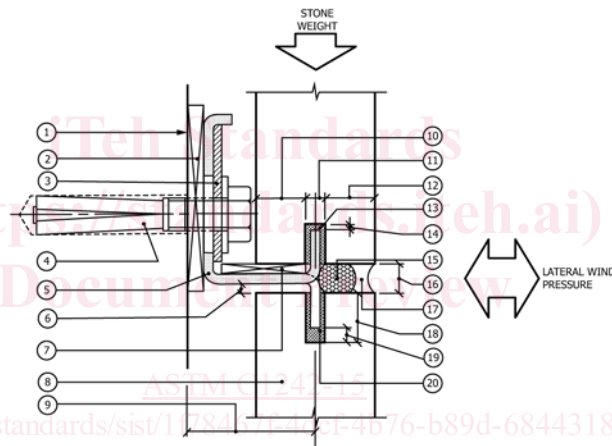

ANCHOR IN HORIZONTAL JOINT CAN SUPPORT GRAVITY AND LATERAL LOADS (FIGURE AS SECTION VIEW)
 ANCHOR IN VERTICAL JOINT CAN SUPPORT ONLY LATERAL LOADS (FIGURE AS PLAN VIEW)

- | | |
|---|--|
| <ul style="list-style-type: none"> ① SUPPORT ANCHORAGE ON COMPATIBLE, STABLE BACKUP. ② PLACE PLASTIC OR METAL ADJUSTMENT BEARING SHIM SLIGHTLY LARGER THAN ANCHOR'S FASTENED FACE. REQUIRED TO SEPARATE DISSIMILAR MATERIALS AND ADJUST TO FRAMING. MINIMIZE THICKNESS TO MINIMIZE BENDING ON FASTENER (PART 4). ③ PREVENT SLIP OF THE CONNECTION AFTER VERTICAL ADJUSTMENT WITH DIAGONALLY SLOTTED WASHER PLATE. WELD WASHER WITH WELD, OR SERRATED ANCHOR AND WASHER. DO NOT RELY ON FRICTION. ④ ATTACH ANCHOR WITH FASTENER TO BACKUP. ⑤ KERF ANCHOR. (BRAKE-FORMED SPLIT-EAR SHAPE SHOWN) OR EXTRUDED SHAPE THAT FITS INTO SAWN KERF. AVOID MISALIGNMENT AND RESULTING PRYING ON KERF FROM INACCURATE FABRICATION OR INSTALLATION. SHOULD NOT BE CONTINUOUS ACROSS PANEL JOINTS. CAPACITY OF CONNECTION IS NOT DIRECTLY PROPORTIONAL TO ANCHOR LENGTH. ⑥ MAINTAIN CLEARANCE TO AVOID CONTACT AND WEIGHT TRANSFER (UNLESS DESIGNED TO STACK). ALLOW FOR MOVEMENT, CREEP, EXPANSION, AND FABRICATION AND INSTALLATION TOLERANCES. ⑦ PLACE PLASTIC OR STIFF RUBBER BEARING SHIM FOR LEVELING, SEPARATION, AND TO PREVENT BEARING OF STONE KERF FIN ON ANCHOR RADIUS. ADJUST ANCHOR VERTICALLY WITH PART 3. NOT SHIMS. ⑧ DIMENSION STONE CLADDING FACE PANEL. ⑨ MINIMIZE DISTANCE TO MINIMIZE ECCENTRIC WEIGHT ON ANCHOR - REDUCES FASTENER (PART 4) PULLOUT AND SUPPORT ANCHOR (PART 5) DISPLACEMENT. ⑩ VERIFY INTERIOR KERF FIN. STONE HERE RESISTS NEGATIVE (OUTWARD OR SUCTION) PRESSURE. MAINTAIN SUFFICIENT WIDTH FROM MINIMUM PANEL THICKNESS. | <ul style="list-style-type: none"> ⑪ LOCATE CONTINUOUS OR INTERMITTENT SAWCUT KERF IN CENTER THIRD OF THICKNESS. CONTROL WIDTH TO ALLOW TOLERANCE WITH KERF ANCHOR. MINIMIZE WIDTH TO MAXIMIZE EDGE DISTANCES (PARTS 10 AND 12). ⑫ VERIFY EXTERIOR KERF FIN. (3/8 IN. (10 mm) MINIMUM) STONE HERE RESISTS POSITIVE (INWARD) PRESSURE. KEEP THIS DIMENSION CONSTANT TO KEEP STONE FACES ALIGNED. ⑬ FILL KERF IN BOTTOM EDGE OF STONE ONLY AT ANCHORS WITH SEALANT TO SET POSITION AND TO CUSHION BEARING. ⑭ MAINTAIN CLEARANCE TO AVOID POINT LOADING AT TOP AND BOTTOM. DIMENSION TO EQUAL OR EXCEED PART 6. DO NOT ALLOW FLOOR-TO-FLOOR MOVEMENTS TO OCCUR IN THE KERF. ⑮ PLACE BACKER ROD OR FOAM TAPE AT PROPER DEPTH TO PREVENT THREE-SIDED SEALANT BOND. ⑯ SIZE JOINTS TO ALLOW FOR HARDWARE, TOLERANCES, CLEARANCES, APPROPRIATE MOVEMENT, AND JOINT FILLER CAPABILITY. ISOLATE DYNAMIC BUILDING MOVEMENTS FROM THIS TYPE OF ANCHOR. ⑰ FILL JOINTS BETWEEN PANELS WITH COMPRESSIBLE GASKET OR SEALANT WITH PROPER PROFILE AND COMPATIBILITY. ⑱ MINIMIZE KERF DEPTH TO MINIMIZE PRYING AND MAXIMIZE CAPACITY. MAINTAIN 3/8 IN. (10 mm) MINIMUM OR TESTED MINIMUM ENGAGEMENT. ⑲ MAINTAIN CLEARANCE TO AVOID POINT LOADING AT KERF IN TOP OF STONE. DIMENSION TO EQUAL OR EXCEED PART 6. DO NOT ALLOW DYNAMIC DISPLACEMENTS TO OCCUR IN THE KERF. ⑳ FILL KERF IN TOP EDGE OF STONE CONTINUOUSLY WITH SEALANT TO TOP OF KERF TO PREVENT MOISTURE ACCUMULATION, SET POSITION, AND CUSHION BEARING OF ANCHOR ON SIDES OF KERF. |
|---|--|

FIG. 1 Kerf Anchor

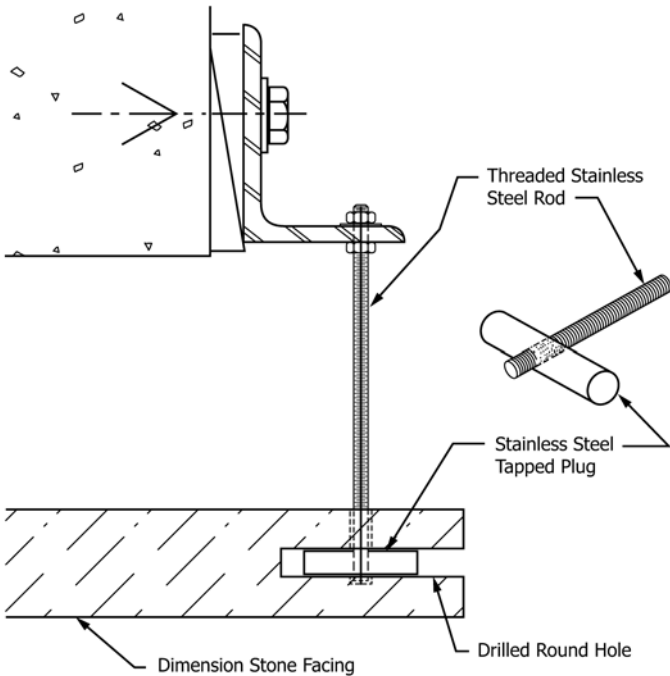

FIG. 2 Rod and Plug Anchor

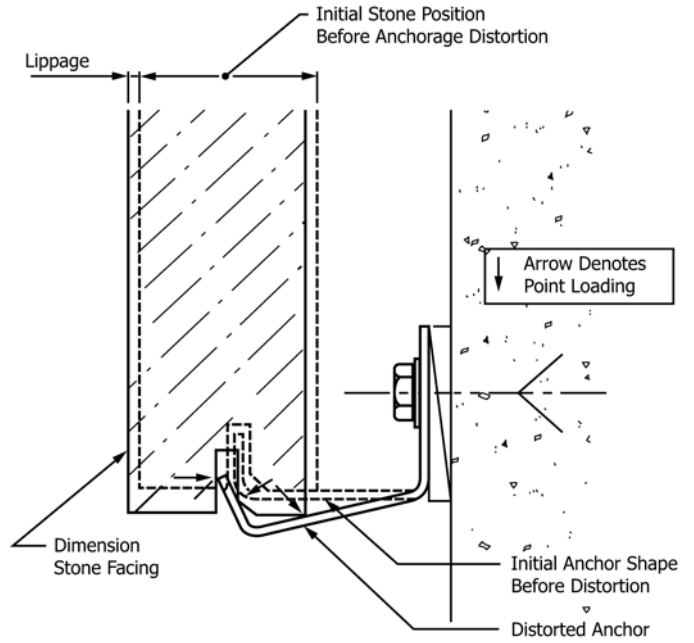

FIG. 4 Point Loading Prevention

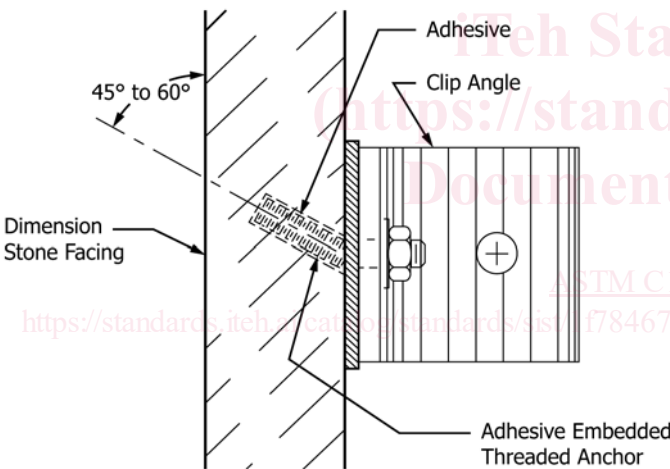

FIG. 3 Adhesive Embedded Threaded Anchor

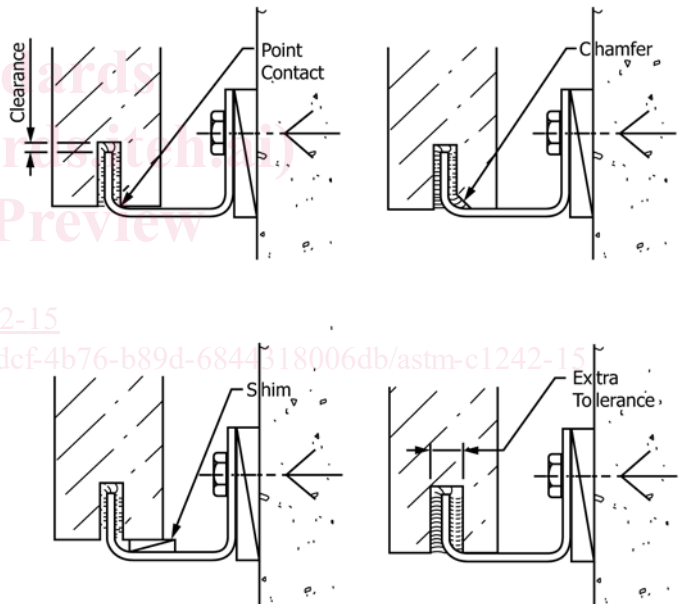

FIG. 4 Point Loading Prevention (continued)

- [C1201 Test Method for Structural Performance of Exterior Dimension Stone Cladding Systems by Uniform Static Air Pressure Difference](#)
- [C1354/C1354M Test Method for Strength of Individual Stone Anchorages in Dimension Stone](#)
- [C1472 Guide for Calculating Movement and Other Effects When Establishing Sealant Joint Width](#)
- [C1496 Guide for Assessment and Maintenance of Exterior Dimension Stone Masonry Walls and Facades](#)
- [C1526 Specification for Serpentine Dimension Stone](#)
- [C1527 Specification for Travertine Dimension Stone](#)
- [E632 Practice for Developing Accelerated Tests to Aid Prediction of the Service Life of Building Components and Materials](#)

3. Terminology

3.1 *General Definitions*—For definitions of terms used in this guide, refer to Terminology C119.

3.2 Specific definitions used in the design process are listed in 7.4.

4. Significance and Use

4.1 This guide is intended to be used by architects, engineers, and contractors who either design or install exterior stone cladding for architectural structures.

4.2 This guide is an industry standard for engineering design considerations, documentation, material considerations,

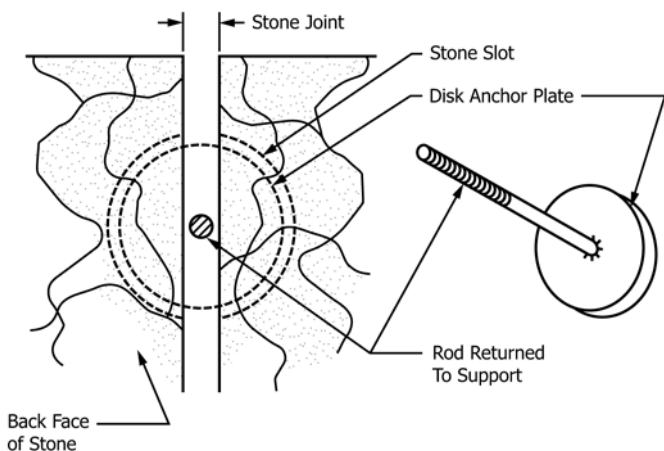

FIG. 5 Disc Anchor

TABLE 1 Dimension Stone Specifications

Stone Type	ASTM Specification
Calcite ^A	C503
Dolomite ^A	C503
Granite	C615
Limestone ^B	C568
Marble (exterior) ^B	C503
Quartz-Based ^B	C616
Quartzite ^A	C616
Quartzitic Sandstone ^A	C616
Sandstone ^A	C616
Serpentine ^A	C503
Serpentine	C1526
Slate (roof)	C406
Slate (walls)	C629
Travertine ^A	C1527

^A This stone type is a subclassification.

^B This stone type has subclassifications or grades.

TABLE 2 Dimension Stone Test Methods

Measures	ASTM Test Method
liquid porosity and relative density	C97
combined shear with tensile unit strength from bending	C99
ultimate crushing unit strength	C170
primary tensile unit strength from bending	C880
capacity and deflections of panels assembled with their anchors onto their supporting backup structure	C1201
individual anchor strength	C1354/C1354M
accelerated production of service life	E632

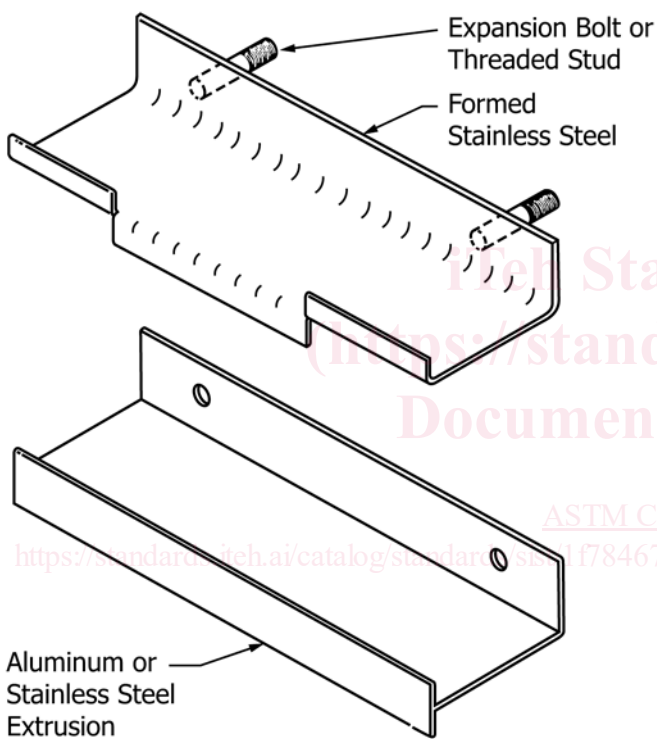

FIG. 6 Combined Anchor

anchor type applications, and installation workmanship to assist designers and installers to achieve a proper and durable stone cladding.

4.3 Stone and its support systems are part of a building’s skin and shall be compatible with the behavior and performance of other interfacing systems, such as the curtainwall and superstructure frame.

4.3.1 Every stone work application shall comply with applicable building codes.

4.3.2 It is not the intent of this Guide to supersede published recommendations for specific stone types. Provisions of other dimension stone industry publications should be reviewed and considered in addition to this Guide’s recommendations. All industry information should be considered with respect to project specifications and requirements. If provisions of such

publications differ from those in this Guide, it is acceptable practice to follow the publication’s provisions if recommended by the stone specialist defined in 4.4 for the specific conditions of the individual project.

4.3.3 Because stone properties vary, the range and variability of pertinent properties of the stone proposed for use should be determined by testing and statistical methods that are evaluated using sound engineering principles. Use recent test data where applicable. Always reference proven performance of relevant existing structures.

4.3.4 Changes in properties over time shall be considered.

4.3.5 Overall behaviors of all building systems and components including the stone shall be interactively compatible.

4.4 *Stone Specialist*—Some conditions require professional expertise to select and plan a proper anchoring system, establish appropriate testing requirements, interpret tests, design and engineer the anchoring system, or monitor its fabrication and installation. A specialist is a person that complements the capabilities of the project team by contributing specific expert experience with the use, selection, design, and installation of dimension stone.

4.4.1 Particular conditions where special expertise is suggested to achieve a reliable installation:

4.4.1.1 Where complex connections or anchoring methods of unknown or questionable performance records are likely to be considered or specified;

4.4.1.2 Where the performance record of the specified systems and materials is not known or questionable;

4.4.1.3 When multiple cladding materials occur on the same facade;

4.4.1.4 If the supporting structure or backup is more flexible than L/600 in any direction;

4.4.1.5 If extreme loading could be caused by seismic, hurricane, tornado, or installation and handling methods;

4.4.1.6 When special building code requirements prevail.

4.4.1.7 If provisions of stone industry publications or project specifications differ from this guide.

5. Selection Considerations

5.1 Review the following factors before selecting a stone material, an anchoring system and subframe system from those options being considered:

5.1.1 Have the stone materials under consideration performed well on existing buildings in similar exposures?

5.1.2 Have the different anchoring and subframe systems under consideration performed well on existing buildings in similar exposures?

5.1.3 How is the performance of the anchor and its engagement into the stone affected by installation and handling procedures?

5.1.4 How are the performance and appearance of the subframe, the anchor's connection to the subframe, and the subframe's connections to the building structure affected by differential movements?

5.1.5 Do the physical characteristics of the stone measured by standard tests show the material has structural limitations? Which physical properties are important to the application, and which test methods measure those properties and their variability? Refer to **Table 2** for standard test methods and properties they measure.

5.1.6 Do the physical characteristics of the stone not measured by standard tests suggest the material may have long-term durability concerns? Other properties, including (but not limited to) resistance to chemical attack, weather-related strength reduction, and dimensional changes, might be evaluated by special laboratory tests designed to obtain data under simulated conditions.

5.1.7 Does the project location or shape develop exceptional design wind, or seismic loads, or does the stone material require higher safety factors than other stones not anticipated by statutory codes?

5.1.8 Do the anchor and subframe system accommodate building dimensional changes caused by wind and seismic sway, thermal and elastic deformation, creep and shrinkage, and their combined effects?

5.1.9 Will contiguous facade elements such as windows, other claddings, window supports, or window-washing and wall maintenance provisions influence the stone cladding, its anchoring or subframe system?

5.1.10 Do the anchor or subframe systems penetrate waterproofing, facilitate internal moisture collection, or penetrate wall insulation and cavity ventilation?

5.1.11 Do the materials used resist corrosion, galvanic and chemical reactions?

5.2 The following general rules are helpful in the design of anchors and connections:

5.2.1 The simplest connections are usually the best.

5.2.2 Make connections with the fewest components.

5.2.3 Use the fewest possible anchor connection types in any particular project.

5.2.4 Provide for adjustability in connections to accommodate tolerances in materials and construction.

5.2.5 Distribute the weight of stone or panel systems on no more than two points of connection where possible.

5.2.6 Make anchor connection locations accessible to the craftsman.

5.2.7 Design connection components and stone sinkages to avoid entrapping moisture.

5.2.8 At friction connections with slotted holes parallel to the direction of load, specify proper bolts, washers, slot size, and bolt installation procedure.

5.3 *Safety Factors*—In order to design an anchoring system, the variabilities of the materials being considered should be known and compensated. This is accomplished through the use of an appropriate safety factor to be applied to the stone, the anchorage, and the backup structure.

5.3.1 **Table 3** shows generally accepted Safety Factors for stone cladding by stone type. These factors are recognized by industry specialists and publications and are based upon past successful practice. These factors are based on a maximum coefficient of variation of 20 % when project samples are tested in accordance with Test Methods **C99** or **C880** for sedimentary stones in thicknesses of 2 in. (50 mm) or greater. Safety factors could be changed when conditions listed under **5.3.2** or **5.3.3** exist in the project.

5.3.2 *Exemplar Availability*: A safety factor could be modified if the long-term performance of the stone material, anchor and backup system cannot be verified by well-performing exemplars. Consult a stone specialist as defined in **4.4** for the appropriate change in safety factor.

5.3.3 *Structural Variables*: A safety factor could be modified if specific conditions exist on the project different from those upon which **Table 3** values are based. Consult a stone specialist as defined in **4.4** for the appropriate change in safety factor. Some specific conditions are:

5.3.3.1 Critical material strength tests show increased variability;

5.3.3.2 Life expectancy of project exceeds forty years;

5.3.3.3 Stone material loses significant strength over time;

5.3.3.4 When designing stone at anchors;

5.3.3.5 Anchor capacity tests show increased variability;

5.3.3.6 Anchors will not be inspected in final position on building;

5.3.3.7 Anchors require varied installation techniques or varied positions;

TABLE 3 Generally Accepted Safety Factors for Stone Cladding by Stone Type

Stone Type	Specification	Safety Factor
granite	C615	3
limestone	C568	6
group A marble	C503	5
travertine	C1527	8
sandstone	C616	6
slate	C629	5

5.3.3.8 Panel is used in higher-risk position such as a soffit, overhang, liner block, assembled on backup before being erected or other similar position.

6. Anchor Types

6.1 The following descriptions apply to components potentially common to all anchor types:

6.1.1 Connect all anchors to a stable backup. A stable backup provides sufficient strength and stiffness to resist forces, rotations and displacements induced by the anchor as it transfers reactions from the stone panel to the backup to sustain the structural integrity of the stone cladding. Strength and stiffness must also be sufficient to prevent stress concentrations that could compromise capacity, so the stone cladding system can perform as engineered.

6.1.2 Place structural shims between the anchor and backup to accommodate variances in position between the finished stone panel's position and actual location of the backup. Shims must possess permanent structural properties sufficient to transfer forces while resisting rotations and displacements between the anchor and backup that could compromise the anchor or fastener capacity, or its intended position. Insulation, waterproofing, compressible or elastomeric layers not possessing sufficient structural properties should not be used as shims, and should not be sandwiched between anchors and backup at bearing surfaces. Prevent unintended slip at adjustment slot with weld washer, interlocking serrated faces, or other mechanical means whether in the vertical, horizontal, or diagonal direction.

6.1.3 Where required to adjust the stone panel's height during setting, place structural shims between the stone and

anchor to accommodate variances in position between the finished stone panel's position and actual location of the anchor. Shims must possess permanent structural properties sufficient to transfer forces while allowing rotations and slight displacements between the anchor and stone panel that, if restricted, could induce prying and compromise the anchor or stone's capacity where it is engaged by the anchor.

6.2 Precast Anchors (see Fig. 7):

6.2.1 Smooth dowels, wire hairpins (preformed wire spring-type anchors), threaded rods or bolts are used as anchors to attach stone cladding to precast concrete panels. Adhesives compatible with the stone may be used in conjunction with such anchors. However, relying solely on adhesives to support stone is not recommended.

6.2.1.1 The number of dowels is determined by analysis and testing.

6.2.1.2 The dowels anchor the cladding to the concrete backup. The angle of the dowel to the stone is usually 45°, angled into the precast, with the patterns opposing each other within the same stone. The holes for the dowels should be jig-drilled with diamond core bits. (See Fig. 7.)

6.2.1.3 The dowel embedment in to the stone should be a minimum of two-thirds of the thickness of the stone. The bottom of the dowel hole should not be closer than 3/8 in. (9.5 mm) to the face of the stone. The embedded section of the dowel into the precast concrete backup should not be less than 2 1/2 in. (64 mm).

6.2.1.4 All dowels should be within the limits of the concrete reinforcing cage when viewed in elevation.

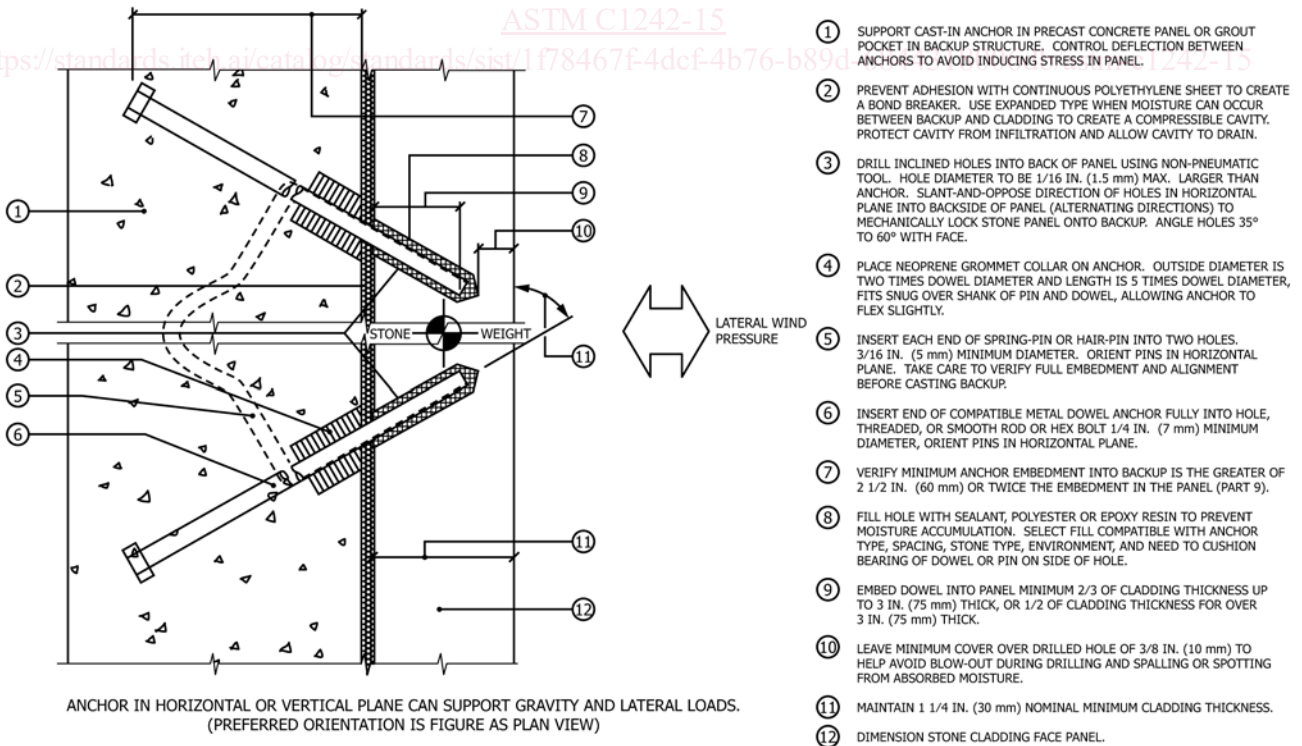

- ① SUPPORT CAST-IN ANCHOR IN PRECAST CONCRETE PANEL OR GROUT POCKET IN BACKUP STRUCTURE. CONTROL DEFLECTION BETWEEN ANCHORS TO AVOID INDUCING STRESS IN PANEL.
- ② PREVENT ADHESION WITH CONTINUOUS POLYETHYLENE SHEET TO CREATE A BOND BREAKER. USE EXPANDED TYPE WHEN MOISTURE CAN OCCUR BETWEEN BACKUP AND CLADDING TO CREATE A COMPRESSIBLE CAVITY. PROTECT CAVITY FROM INFILTRATION AND ALLOW CAVITY TO DRAIN.
- ③ DRILL INCLINED HOLES INTO BACK OF PANEL USING NON-PNEUMATIC TOOL. HOLE DIAMETER TO BE 1/16 IN. (1.5 mm) MAX. LARGER THAN ANCHOR. SLANT-AND-OPPOSE DIRECTION OF HOLES IN HORIZONTAL PLANE INTO BACKSIDE OF PANEL (ALTERNATING DIRECTIONS) TO MECHANICALLY LOCK STONE PANEL ONTO BACKUP. ANGLE HOLES 35° TO 60° WITH FACE.
- ④ PLACE NEOPRENE GROMMET COLLAR ON ANCHOR. OUTSIDE DIAMETER IS TWO TIMES DOWEL DIAMETER AND LENGTH IS 5 TIMES DOWEL DIAMETER, FITS SNUG OVER SHANK OF PIN AND DOWEL, ALLOWING ANCHOR TO FLEX SLIGHTLY.
- ⑤ INSERT EACH END OF SPRING-PIN OR HAIR-PIN INTO TWO HOLES. 3/16 IN. (5 mm) MINIMUM DIAMETER. ORIENT PINS IN HORIZONTAL PLANE. TAKE CARE TO VERIFY FULL EMBEDMENT AND ALIGNMENT BEFORE CASTING BACKUP.
- ⑥ INSERT END OF COMPATIBLE METAL DOWEL ANCHOR FULLY INTO HOLE, THREADED, OR SMOOTH ROD OR HEX BOLT 1/4 IN. (7 mm) MINIMUM DIAMETER, ORIENT PINS IN HORIZONTAL PLANE.
- ⑦ VERIFY MINIMUM ANCHOR EMBEDMENT INTO BACKUP IS THE GREATER OF 2 1/2 IN. (60 mm) OR TWICE THE EMBEDMENT IN THE PANEL (PART 9).
- ⑧ FILL HOLE WITH SEALANT, POLYESTER OR EPOXY RESIN TO PREVENT MOISTURE ACCUMULATION. SELECT FILL COMPATIBLE WITH ANCHOR TYPE, SPACING, STONE TYPE, ENVIRONMENT, AND NEED TO CUSHION BEARING OF DOWEL OR PIN ON SIDE OF HOLE.
- ⑨ EMBED DOWEL INTO PANEL MINIMUM 2/3 OF CLADDING THICKNESS UP TO 3 IN. (75 mm) THICK, OR 1/2 OF CLADDING THICKNESS FOR OVER 3 IN. (75 mm) THICK.
- ⑩ LEAVE MINIMUM COVER OVER DRILLED HOLE OF 3/8 IN. (10 mm) TO HELP AVOID BLOW-OUT DURING DRILLING AND SPALLING OR SPOTTING FROM ABSORBED MOISTURE.
- ⑪ MAINTAIN 1 1/4 IN. (30 mm) NOMINAL MINIMUM CLADDING THICKNESS.
- ⑫ DIMENSION STONE CLADDING FACE PANEL.

FIG. 7 Cast-In Anchors