



Designation: C583 – 15

Standard Test Method for Modulus of Rupture of Refractory Materials at Elevated Temperatures¹

This standard is issued under the fixed designation C583; the number immediately following the designation indicates the year of original adoption or, in the case of revision, the year of last revision. A number in parentheses indicates the year of last reappraisal. A superscript epsilon (ϵ) indicates an editorial change since the last revision or reappraisal.

1. Scope

1.1 This test method covers determination of the high-temperature modulus of rupture of refractory brick or monolithic refractories in an oxidizing atmosphere and under action of a force or stress that is increased at a constant rate.

1.2 The values stated in inch-pound units are to be regarded as standard. The values given in parentheses are mathematical conversions to SI units that are provided for information only and are not considered standard.

1.3 *This standard does not purport to address all of the safety concerns, if any, associated with its use. It is the responsibility of the user of this standard to establish appropriate safety and health practices and determine the applicability of regulatory limitations prior to use.*

2. Referenced Documents

2.1 *ASTM Standards:*²

[E220 Test Method for Calibration of Thermocouples By Comparison Techniques](#)

3. Significance and Use

3.1 Measuring the modulus of rupture of refractories at elevated temperatures has become a widely accepted means to evaluate materials at service temperatures. Many consumer companies have specifications based on this type of test.

3.2 This test method is limited to furnaces operating under oxidizing conditions. However, with modifications for atmosphere control in other test furnaces, the major criteria of this test procedure may be employed without change.

3.3 This test method is designed for progressive application of a force or stress on a specimen supported as a simple beam with center-point loading. Test apparatus designed for the

progressive application of a strain may yield different results, especially since refractory materials will reach a semiplastic state at elevated temperatures where Hooke's law does not apply, that is, stress is then not proportional to strain.

3.4 This test method applies to fired dense refractory brick and shapes, chemically bonded brick and shapes, shapes formed from castables, plastics, or ramming materials, and any other refractory that can be formed to the required specimen dimension.

4. Apparatus

4.1 Use either an electrically heated or gas-fired furnace (Note 1). A typical cross section of the furnace containing the bearing edges is shown in Fig. 1. At least one pair of lower bearing edges, made from volume-stable refractory material (Note 2), shall be installed in the furnace on 5-in. (127-mm) centers. A thrust column, containing the top bearing edge that is made from volume-stable refractory material, shall extend outside the furnace where means are provided for applying a load. The lower bearing edges and the bearing end of the support column shall have rounded bearing surfaces having about a ¼-in. (6-mm) radius (Note 3). The lower bearing surfaces may be made adjustable, but must attain the standard span of $5 \pm \frac{3}{32}$ in. (127 ± 2 mm). The length of the lower bearing surfaces shall exceed the specimen width by about ¼ in. (6 mm). The load shall be applied to the upper bearing edge by any suitable means. Instrumentation for measuring the load shall be accurate to 1 %. The thrust column shall be maintained in vertical alignment and all bearing surfaces parallel in both horizontal directions.

NOTE 1—The test furnace can be so constructed so that a number of specimens may be heated and tested at the same time. Bearing edges and loading devices may be provided for a number of individual specimens, but a more practical method is to provide means to move individual specimens successively onto a single set of bearing edges for breaking. The use of a separate holding furnace for specimens to be transferred into the test furnace for breaking is also satisfactory.

NOTE 2—A minimum of 90 % alumina content is recommended as a suitable refractory.

NOTE 3—All bearing surfaces should be checked periodically to maintain a round surface.

4.2 It is recommended that the furnace temperature be controlled with calibrated platinum-rhodium/platinum thermocouples connected to a program-controller recorder (see Test

¹ This test method is under the jurisdiction of ASTM Committee C08 on Refractories and is the direct responsibility of Subcommittee C08.01 on Strength.

Current edition approved March 1, 2015. Published April 2015. Originally approved in 1965. Last previous edition approved in 2010 as C583 – 10. DOI: 10.1520/C0583-15.

² For referenced ASTM standards, visit the ASTM website, www.astm.org, or contact ASTM Customer Service at service@astm.org. For *Annual Book of ASTM Standards* volume information, refer to the standard's Document Summary page on the ASTM website.

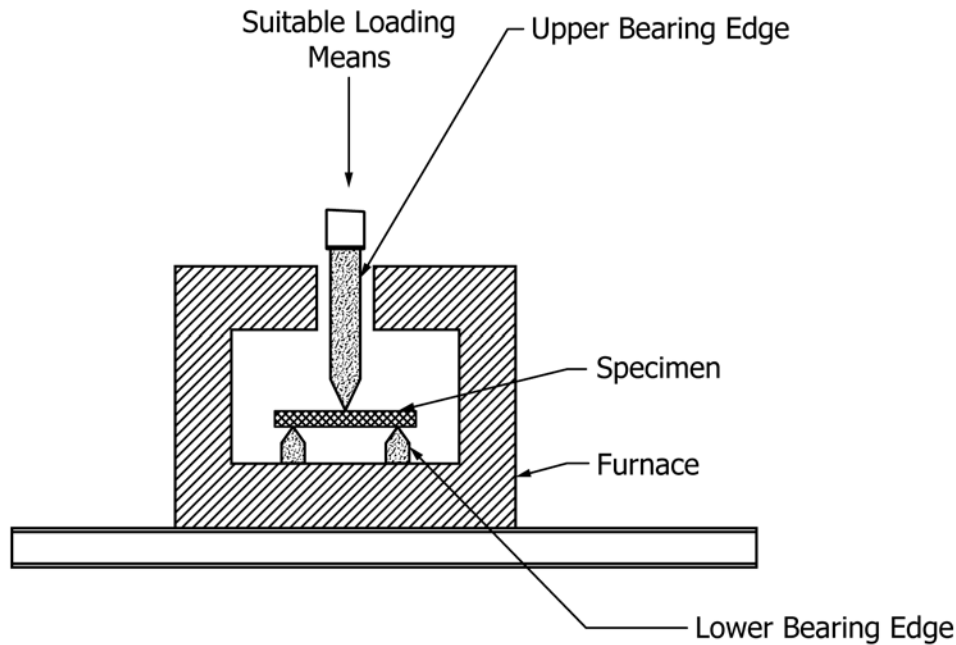

FIG. 1 Cross Section of Typical Apparatus (Heating Means Not Shown)

Method E220). Temperature differential within the furnace shall not be more than $\pm 20^{\circ}\text{F}$ (11°C), but the controlling thermocouple shall be placed within $\frac{1}{2}$ in. (13 mm) of the geometric center of a side face of the test specimen when positioned on the bearing edges.

4.3 *Furnace Atmosphere (gas-fired furnaces only)*—Above a furnace temperature of 1470°F (800°C), the furnace atmosphere shall contain a minimum of 0.5 % oxygen with 0 % combustibles. Take the atmosphere sample from the furnace chamber proper, preferably as near the test specimen as possible.

5. Sampling

5.1 The sample shall consist of five specimens, each taken from five brick or shapes or from test specimens made from monolithic aggregate refractories.

6. Test Specimen

6.1 The standard test specimen shall be $1 \pm \frac{1}{32}$ by $1 \pm \frac{1}{32}$ by approximately 6 in. (25 ± 0.8 by 25 ± 0.8 by approximately 152 mm). Note in the report if other specimen sizes are used. Specimens cut from brick shall have at least one original brick surface. If cut from shapes, the specimens shall be taken parallel to the longest dimension. For irregular shapes, all four long surfaces of the specimen may be cut faces. Note this in the report.

6.2 The relative ratio of the largest grain size to the smallest specimen dimension may significantly affect the numerical results. For example, smaller cut specimens containing large grains may present different results than the bricks from which they were cut. Under no circumstances should 6- by 1- by 1-in. (152- by 25- by 25-mm) specimens be prepared and tested for materials containing grains with a maximum grain dimension exceeding 0.25 in. (6.4 mm).

6.3 Opposite faces of the specimen shall be parallel, and adjacent faces shall be perpendicular.

6.4 Measure the width and depth of the test specimen at mid-span to the nearest 0.01 in. (0.3 mm).

7. Procedure

7.1 Set the specimens in either the test or holding furnace without an applied load, and heat to the test temperature using the following schedule:

7.1.1 *Burned Refractory Products*—The rate of heating from room temperature shall not exceed 600°F (330°C)/h to 1800°F (980°C), and shall not exceed 200°F (110°C)/h from 1800°F to the test temperature (Note 4). Maintain the test temperature for a minimum of 3 h (Note 5).

NOTE 4—Heating at 600°F (330°C)/h can initiate thermal shock in some brick. A maximum heating rate of 150°F (83°C)/h is recommended for materials sensitive to thermal shock.

NOTE 5—Maintaining specimens at test temperature for 3 h before load application is adequate for most compositions and temperatures of interest. However, there may be certain compositions and temperatures requiring additional holding time at temperature in order to obtain consistent results. Experience and use of the test procedure will aid in determining when exploratory testing is required to arrive at the holding time necessary. If departure is made from the specified minimum time, the holding time used will be included in the report of the results.

7.1.2 *Unburned or Chemically Bonded Refractory Products*—The rate of heating from room temperature shall be 600°F (330°C)/h to 1800°F (980°C), and 200°F (110°C)/h from 1800°F to the test temperature. Maintain the test temperature for a minimum of 12 h.

7.2 Following the holding period, move the specimen to the supporting bearing edges. When possible, an original face of the specimen shall be used for the tension face, that is, the face in contact with the two lower bearing edges. Apply the load parallel to the direction (if known) of pressing of the specimen.