



Designation: **D4290 – 07 (Reapproved 2012) D4290 – 15**

Standard Test Method for Determining the Leakage Tendencies of Automotive Wheel Bearing Grease Under Accelerated Conditions¹

This standard is issued under the fixed designation D4290; the number immediately following the designation indicates the year of original adoption or, in the case of revision, the year of last revision. A number in parentheses indicates the year of last reapproval. A superscript epsilon (ϵ) indicates an editorial change since the last revision or reapproval.

1. Scope—Scope*

1.1 This test method covers a laboratory procedure for evaluating leakage tendencies of wheel bearing greases when tested under prescribed conditions.

1.2 The values stated in SI units are to be regarded as standard. No other units of measurement are included in this standard. The exception is apparatus dimensions, in inches, which are to be regarded as the standard.

1.3 *This standard does not purport to address all of the safety concerns, if any, associated with its use. It is the responsibility of the user of this standard to establish appropriate safety and health practices and determine the applicability of regulatory limitations prior to use.* For specific warning statements, see Section 8.

2. Referenced Documents

2.1 *AFBMA Standard*:²

AFBMA Standard 19 1974 (ANSI B.3.19-1975)

3. Terminology

3.1 *Definitions*:

3.1.1 *lubricant, n*—any material interposed between two surfaces that reduces the friction or wear between them.

3.1.2 *lubricating grease, n*—a semifluid to solid product of a dispersion of a thickener in a liquid lubricant.

¹ This test method is under the jurisdiction of ASTM Committee D02 on Petroleum Products—Products, Liquid Fuels, and Lubricants and is the direct responsibility of Subcommittee D02.G0.05 on Functional Tests - Temperature.

Current edition approved April 15, 2012; April 1, 2015. Published May 2012; April 2015. Originally approved in 1983. Last previous edition approved in 2007 as D4290-07 (2012). DOI: 10.1520/D4290-07R12; 10.1520/D4290-15.

² Available from American National Standards Institute (ANSI), 25 W. 43rd St., 4th Floor, New York, NY 10036-10036, <http://www.ansi.org>.

3.1.2.1 Discussion—

The dispersion of the thickener forms a two-phase system and immobilizes the liquid lubricant by surface tension and other physical forces. Other ingredients are commonly included to impart special properties.

3.1.3 *thickener, n—in lubricating grease*, a substance composed of finely-divided particles dispersed in a liquid lubricant to form the product's structure.

3.1.3.1 Discussion—

The solid thickener can be fibers (such as various metallic soaps) or plates or spheres (such as certain non-soap thickeners) which are insoluble or, at the most, only very slightly soluble in the liquid lubricant. The general requirements are that the solid particles be extremely small, uniformly dispersed, and capable of forming a relatively stable, gel-like structure with the liquid lubricant.

3.2 *Definitions of Terms Specific to This Standard*:

3.2.1 *automotive wheel bearing grease, n*—a lubricating grease specifically formulated to lubricate automotive wheel bearings at relatively high grease temperatures and bearing speeds.

3.2.2 *leakage, n—of wheel bearing grease*, separation and overflow of grease or oil from the bulk grease charge, induced by high temperatures and bearing rotation.

*A Summary of Changes section appears at the end of this standard

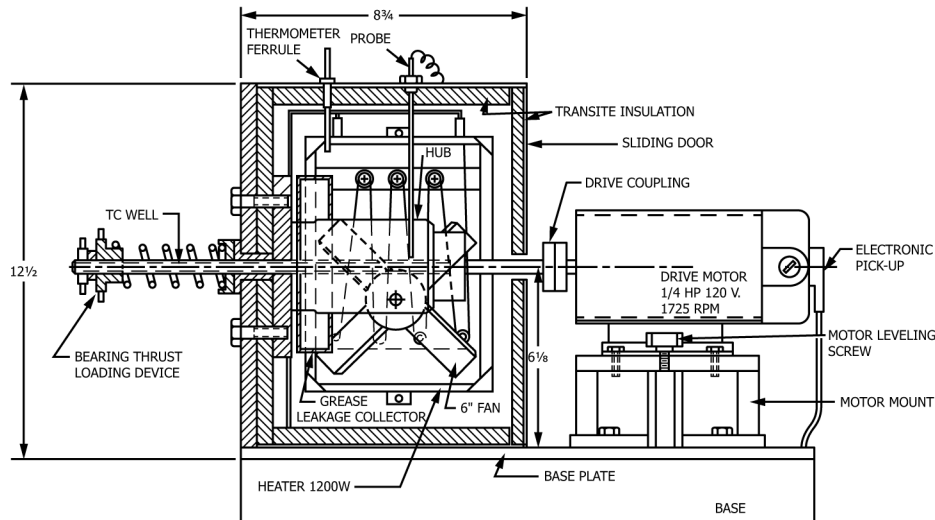

NOTE 1—Caution should be taken when modifying older units since some may still contain asbestos insulation leading to a possible inhalation hazard.

FIG. 1 Wheel Bearing Lubricant Tester (Elevation View)

4. Summary of Test Method

4.1 The test grease is distributed in a modified, automobile front wheel hub-spindle-bearings assembly. While the bearings are thrust-loaded to approximately 111 N, the hub is rotated at 1000 rpm and the spindle temperature maintained at $160 \pm 1.5 \text{ }^\circ\text{C}$ for 20 h. Leakage of grease or oil, or both, is measured, and the condition of the bearing surface is noted at the end of the test.

5. Significance and Use

5.1 This test method differentiates among wheel bearing greases having distinctly different high-temperature leakage characteristics. It is not the equivalent of longtime service tests.

5.2 This test method has proven to be helpful in screening greases with respect to leakage tendencies for automotive wheel bearing applications.

NOTE 1—It is possible for skilled operators to observe changes in grease characteristics that can occur during the test, such as grease condition. Leakage is reported as a quantitative value, whereas the evaluation of grease condition is subject to differences in personal judgment among operators and cannot be used effectively for quantitative measurements.

6. Apparatus

6.1 *Test Assembly* (Figs. 1 and 2).

6.1.1 *Custom-made Wheel Hub-Spindle-Bearing Assembly* (Fig. 3).

6.1.2 *Oven*, electrically heated by 1800 watt heater, thermostatically controlled to maintain spindle temperature at $160 \pm 1.5 \text{ }^\circ\text{C}$.

6.1.3 *Spindle Drive Motor*, 1/4 hp, 120 volts dc with ~~1725 rpm~~ 1725 rpm speed control for the hub; motor torque is indicated by a meter equipped with an adjustable, automatic cutoff.

6.1.4 *Fan Drive Motor*, 1/30 hp, 120 v dc, 1550 rpm.

6.2 Motor speed, oven temperature, spindle temperature, time cycles and torque are controlled or monitored, or both, by accessory equipment.

6.3 A grease slinger has been added since the original design of the apparatus. Fig. 4 shows the slinger used for the hub of Koehler and Pam apparatus.

NOTE 2—The slinger was developed to prevent grease from creeping along the hub and being slung off past the grease collector. Greases that crept during the test can lead to erroneously low results. Addition of the slinger will not affect the precision data in Section 13 because none of the round-robin greases exhibited grease creepage.

6.4 *Balance*, having a minimum capacity of 100 g and minimum sensitivity of 0.1 g.

7. Test Bearings

7.1 Use LM67048-LM67010 and LM11949-LM11910 (AFBMA Standard 19) inboard and outboard bearings, respectively.

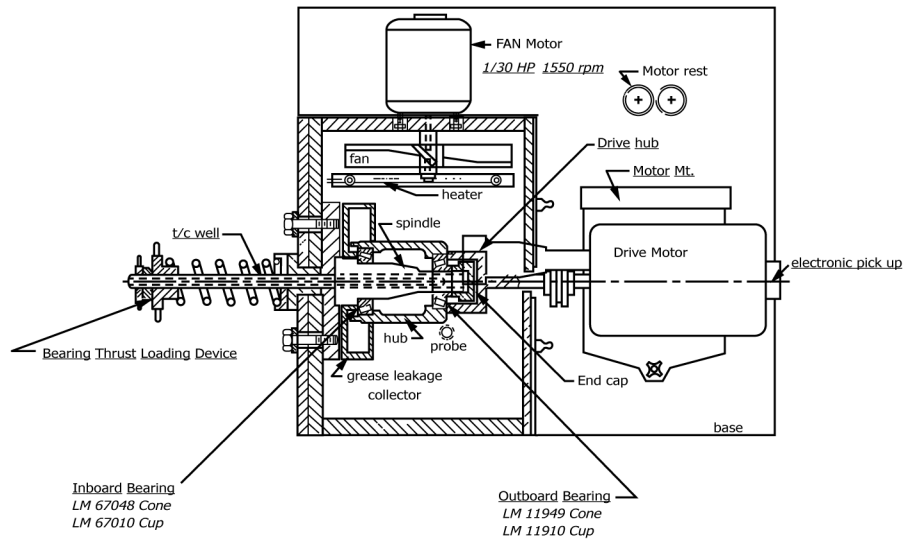

FIG. 2 Wheel Bearing Lubricant Tester (Top View)

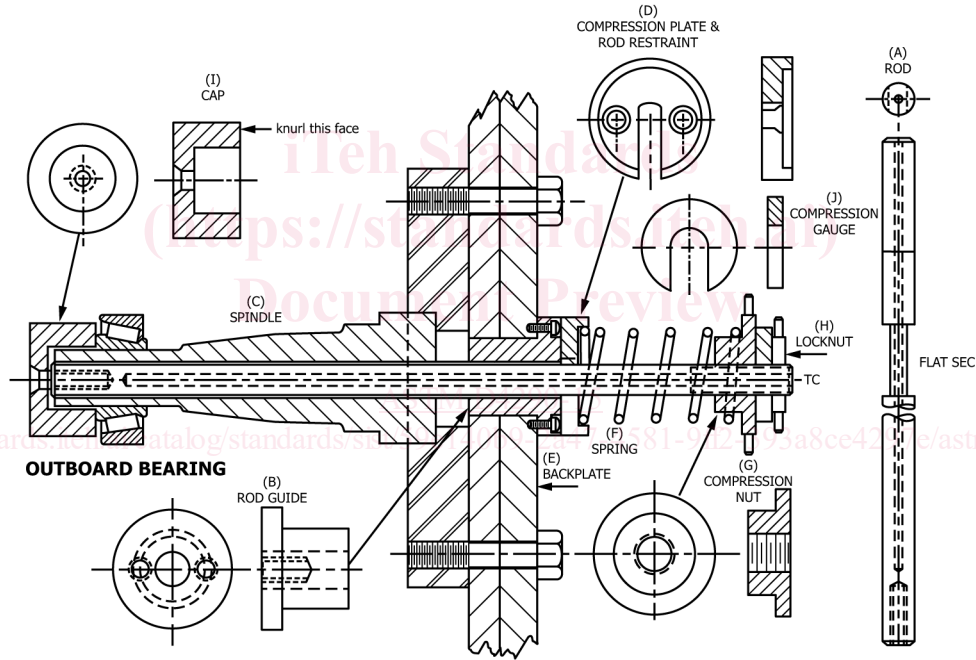

FIG. 3 Spindle and Thrust Rod Components

8. Reagents and Materials

- 8.1 Penmul L460 (previously called Penetone-ECS)³—(Warning—Combustible. Vapors can be harmful.)
- 8.2 *n*-heptane—reagent grade minimum purity. (Warning—Flammable. Harmful if inhaled.)
- 8.3 Isopropyl Alcohol—reagent grade minimum purity. (Warning—Flammable.)
- 8.4 Mineral Spirits—reagent grade. (Warning—Combustible. Vapors may be harmful.)
- 8.5 SAE 10W Engine Oil.
- 8.6 00 Grade Steel Wool.

³ The sole source of supply of Penmul L460 (previously called Penetone-ECS) known to the committee at this time is Penetone Corp., 74 Hudson Ave., Tenaply, NJ 07670. If you are aware of alternative suppliers, please provide this information to ASTM International Headquarters. Your comments will receive careful consideration at a meeting of the responsible technical committee,¹ which you may attend.

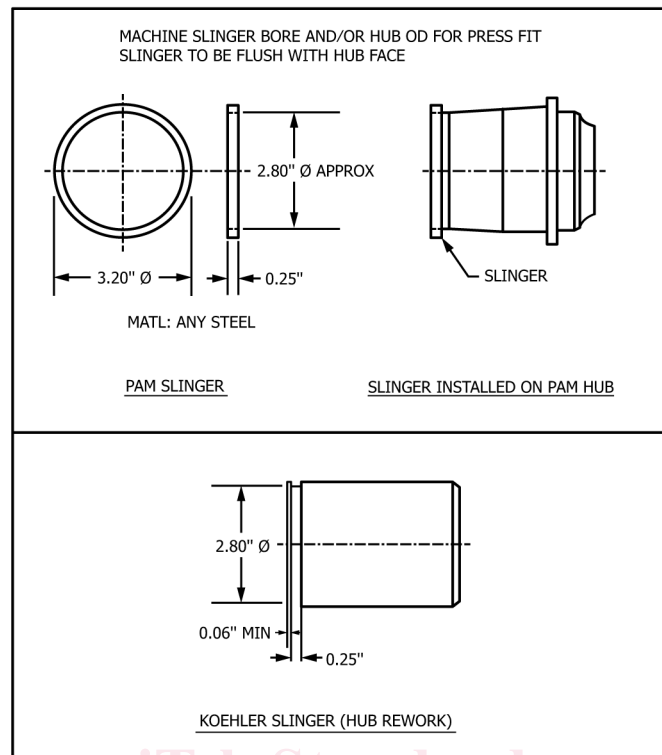

FIG. 4 Grease Slingers for Pam and Koehler Hubs

9. Preparation of Bearings

9.1 Carefully remove new bearings (cups and cones) from their packages and place in a suitable clean container. Wash with *n*-heptane to remove all rust preventative.

9.2 Repeat washing with *n*-heptane two additional times to be certain all rust preventative has been removed. Use a clean beaker each time.

9.3 Drain *n*-heptane from the bearings and set them on a clean, lint-free cloth or towel to air dry.

NOTE 3—Cleaning may be facilitated by the use of a sonic cleaner.

10. Procedure

10.1 Prior to each test, check the freedom of movement of the thrust loading shaft (Fig. 3) in the spindle. If binding is noted, remove and clean both shaft and spindle bore.

10.2 Install new cups in the cleaned hub in the location shown by Figs. 1 and 2.

10.3 Weigh an inboard and outboard bearing cone to the nearest 0.1 g. Using the grease packer shown in Figs. 5 and 6 and an extra set of cups, fill the cones with the test grease. Use care to avoid moving the rollers or bearing components while removing the cones from the cups and in all subsequent wiping and handling steps. Strike off excess grease flush with the front face of the cone (near small end of rollers) using a small spatula. Wipe all grease from cone bore, cone back face, exterior cage surfaces, and exposed roller surfaces with a clean, lint-free cloth or towel and reweigh. Adjust the grease weight in the inboard cone to 3.0 ± 0.1 g and in the outboard cone to 2.0 ± 0.1 g by wiping or adding grease to the groove between the cage and the cone back face. Apply a thin film of grease on the cups.

10.4 Distribute 55.0 ± 0.2 g of grease in a uniform layer in the hub.

10.5 Weigh the leakage collector to the nearest 0.1 g.

10.6 Install the leakage collector, inboard cone, hub, and outboard cone on the spindle (Fig. 2). Lock the components in place with the end cap and screw. Install the spindle connector.

10.7 Referring to Fig. 3, adjust the thrust load as follows: Tighten the compression nut (G) until the spring (F) is seated against the back plate (E), *but not compressed*. Bring the lock nut (H) up to the compression nut (G). Without moving H, compress F by tightening G until the compression gage (J) will fit between H and G. Hold J in position and back off G until J is held firmly between H and G.