



Designation: ~~D2221 – 01 (Reapproved 2010)~~ D2221 – 01 (Reapproved 2015)

Standard Test Method for Creep Properties of Package Cushioning Materials¹

This standard is issued under the fixed designation D2221; the number immediately following the designation indicates the year of original adoption or, in the case of revision, the year of last revision. A number in parentheses indicates the year of last reapproval. A superscript epsilon (ϵ) indicates an editorial change since the last revision or reapproval.

This standard has been approved for use by agencies of the U.S. Department of Defense.

1. Scope

1.1 This test method covers the determination of creep properties of package cushioning materials. It is applicable to materials available in bulk, sheet, or molded form used for the cushioning of articles during storage, handling, and shipment.

1.2 The values stated in inch-pound units are to be regarded as standard. The values given in parentheses are mathematical conversions to SI units that are provided for information only and are not considered standard.

1.3 *This standard does not purport to address all of the safety concerns, if any, associated with its use. It is the responsibility of the user of this standard to establish appropriate safety and health practices and determine the applicability of regulatory limitations prior to use.*

2. Referenced Documents

2.1 *ASTM Standards:*²

[D4332 Practice for Conditioning Containers, Packages, or Packaging Components for Testing](#)

[E105 Practice for Probability Sampling of Materials](#)

[E122 Practice for Calculating Sample Size to Estimate, With Specified Precision, the Average for a Characteristic of a Lot or Process](#)

3. Terminology

3.1 *Definitions of Terms Specific to This Standard:*

3.1.1 *creep*—the deformation of a material occurring with time and due to an externally applied constant stress. For cushioning materials specifically, it may be defined as the change in thickness of a cushion under static compressive load over a period of time.

3.1.2 *permanent set*—the permanent change in thickness of an unloaded cushion as a result of an applied compressive load for any given time interval and any given unloaded recovery time period.

4. Summary of Test Method

4.1 The test apparatus consists of a suitable testing device having a base plate and a guided movable platen which can be loaded with weights. The loaded movable platen is placed on a cushion to simulate static compressive loading of cushioning material in actual packaging. By measuring the change in thickness of the loaded cushion with time, creep properties of the cushioning material can be obtained.

5. Significance and Use

5.1 This test method determines the extent and nature of cushion thickness change under static load. Creep data obtained by this test method are applicable to the cushion under the conditions of the particular test and are not necessarily the same as obtained in a complete pack in actual packaging environments. Data may be affected by magnitude of static load, specimen area, shape, and thickness, by varying ambient conditions of temperature, humidity, by friction in the movable platen guide system, and by actual cushion thickness. Vibration in the vicinity of the test fixtures may also influence data results.

¹ This test method is under the jurisdiction of ASTM Committee [D10](#) on Packaging and is the direct responsibility of Subcommittee [D10.13](#) on Interior Packaging. Current edition approved April 1, 2015. Published ~~January 2010~~ May 2015. Originally approved in 1963. Last previous edition approved in ~~2001~~ 2010 as [D2221 – 01](#); [D2221 – 01 \(2010\)](#). DOI: ~~10.1520/D2221-01R10~~ 10.1520/D2221-01R15.

² For referenced ASTM standards, visit the ASTM website, www.astm.org, or contact ASTM Customer Service at service@astm.org. For *Annual Book of ASTM Standards* volume information, refer to the standard's Document Summary page on the ASTM website.

6. Apparatus

6.1 *Movable, Guided Platen*, capable of being weighted to achieve the desired loading along with a base to support the sample throughout the duration of the test. Two such assemblies are shown in Fig. 1 and Fig. 2.

6.2 *Static Load Box Fixture* (Fig. 1), consisting of a movable guided platen and an outer box that shall act as the guide and the base plate for supporting the sample.

6.2.1 *Base Plate (Outer Box)*, may be constructed of 3/4 in. (19.0 mm) minimum white pine and fabricated to reduce swelling which may occur at high humidity. A flat rigid plate of appropriate dimensions is placed on the inside bottom surface and used as the base plate. The plate can be made of a material such as aluminum, steel, rigid plastic sheeting or glass.

6.2.2 *Movable Guided Platen (Inner Box)*, may be loaded with weights (for example, lead shot or molded lead weights), and fabricated in the same manner as described in 6.2.1. A flat rigid plate similar to that described in 6.2.1 is placed between the top of the test specimen and the movable platen and serves as a reference for measuring the height of the specimen.

6.2.3 Two means of measurement, two position and four position, may be utilized. A micrometer or steel rule capable of measurement to 0.01 in. (0.3 mm) shall be utilized.

6.2.3.1 *Two Position*—A vertical line, scribed at the center of both (movable and base) flat, rigid plate edges (Fig. 1) serves as location references for specimen thickness measurements (distance between the plates) at various time intervals. Measurements are taken at the vertical scribed lines at both the front and back of the box.

6.2.3.2 *Four Position*—Measurements are taken at the four box corners for specimen thickness measurements (see 6.2.3.1).

6.3 The single point fixture shall consist of a support structure guiding a rod perpendicularly attached to a platen (see Fig. 2).

6.3.1 The support structure shall be constructed in such a manner as to keep the rod and platen perpendicular to the base without binding. The rod shall be attached to the platen so as to limit lateral motion. (The weight of both platen and rod shall be constructed to achieve the minimum static loading for original thickness measurement in 9.2.) Weights may be added to the platen top surface to achieve the desired static loading.

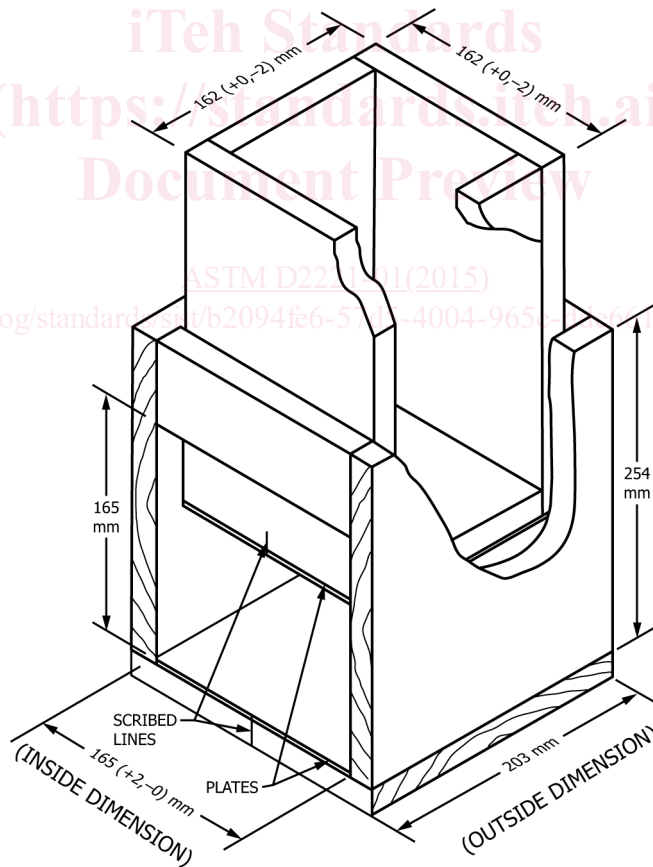

NOTE 1—All dimensions are for reference only and are dependent on the materials tested.

		Inside Dimensions of Outer Box				
		165 (+2,-0) × 165 (+2,-0) × 254 (±3) mm				
mm	2	162	165	203	254	
in.	0.08	6.37	6.50	8	10	

FIG. 1 Typical Static Load Box Creep Apparatus

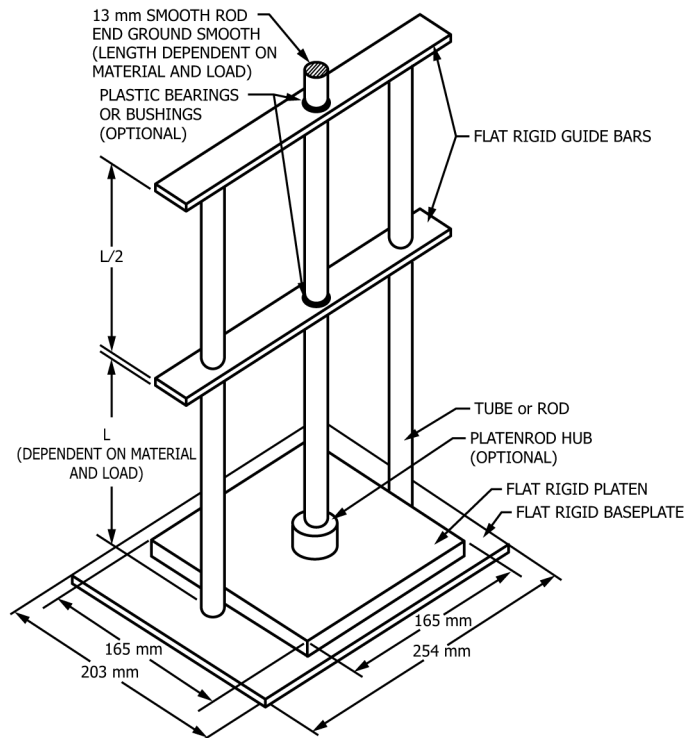

NOTE 1—All dimensions are for reference only and are dependent on the materials tested.

FIG. 2 Typical Single Point Creep Apparatus

6.3.2 Measurements shall be taken from the top of the rod with a dial micrometer or other similar device capable of measurement to 0.01 in. (0.3 mm).

6.4 *Flat Rigid Plate*, for measuring specimen thickness (see 9.2) should be constructed to yield a 0.025 psi (0.17 kPa) static load. Plates referenced in 6.2.1 and 6.2.2 used with the static load box may be utilized if constructed to the proper weight required to achieve the desired static load.

7. Test Specimens

7.1 Test specimens shall be right square prisms or right cylinders with the lateral dimensions at least the same as the original thickness, and with minimum dimensions of not less than 2 by 2 by 1 in. (51 by 51 by 25 mm) thick. The preferred size is 6 by 6 by 4 in. (152 by 152 by 102 mm) thick. If the cushioning material, as supplied, is less than 1 in. (25.4 mm) thick, the required thickness may be obtained by using two or more layers of the material. For thin gage materials requiring the stacking of several layers to achieve the desired specimen thickness, interleaving between layers with light weight, noncompressible, flat, rigid plates can help stabilize the stacked specimen. However, the cumulative thicknesses and weights of these plates must be accounted for in all thickness measurements before calculating any values described in Section 10. Specimens with larger areas are recommended whenever possible and may be dictated by the apparatus used to measure creep. Fiber length, pore size, or the nature of a material may also be determining factors regarding specimen size.

7.2 The number of specimens tested as a sample may vary widely, depending on the intended use of the data. It is recommended that at least four specimens be used for the initial sample of a material. Then, depending on the accuracy and degree of certainty required, this sample size may be increased or decreased. To ensure better representation of the sample, individual specimens should be selected by systematic randomization. This can be done by assigning a consecutive number to each of the specimens of the sample, and then selecting the specimens which have numbers that correspond to a series drawn by lottery. Sampling procedures for selecting specimens are discussed in Practice E105. Procedures for determining the number of specimens required for each sample are given in Practice E122.

8. Conditioning

8.1 Precondition all specimens at any desired condition for a sufficient length of time to essentially achieve equilibrium with the ambient atmosphere. In the absence of more specific requirements, the application of Practice D4332 is recommended or one of the following procedures may be followed: