INTERNATIONAL STANDARD



3653

INTERNATIONAL ORGANIZATION FOR STANDARDIZATION • МЕЖДУНАРОДНАЯ ОРГАНИЗАЦИЯ ПО СТАНДАРТИЗАЦИИ • ORGANISATION INTERNATIONALE DE NORMALISATION

Cinematography — Spindles for 8 mm Type S motion-picture projector reels/spools — Dimensions

Cinématographie — Axes de projecteur pour bobines 8 mm type S — Dimensions

First edition — 1978-11-01

ITeH STANDARD PREVIEW
(standards.iteh.ai)

[ISO 3653:1978](https://standards.iteh.ai/catalog/standards/sist/0428c21b-61d2-4ddf-a076-ad5e5546f2fc/iso-3653-1978)

<https://standards.iteh.ai/catalog/standards/sist/0428c21b-61d2-4ddf-a076-ad5e5546f2fc/iso-3653-1978>

UDC 771.531.352 : 778.553.4

Ref. No : ISO 3653-1978 (E)

Descriptors : cinematography, motion-picture projectors, accessories, bobbins, cylindrical shafts, dimensions

FOREWORD

ISO (the International Organization for Standardization) is a worldwide federation of national standards institutes (ISO member bodies). The work of developing International Standards is carried out through ISO technical committees. Every member body interested in a subject for which a technical committee has been set up has the right to be represented on that committee. International organizations, governmental and non-governmental, in liaison with ISO, also take part in the work.

Draft International Standards adopted by the technical committees are circulated to the member bodies for approval before their acceptance as International Standards by the ISO Council.

International Standard ISO 3653 was developed by Technical Committee ISO/TC 36, *Cinematography*, and was circulated to the member bodies in November 1977.

STANDARD PREVIEW
(standards.iteh.ai)

It has been approved by the member bodies of the following countries :

Austria	India	Sweden
Belgium	Italy	Switzerland
Canada	Japan	Turkey
Czechoslovakia	Mexico	United Kingdom
Denmark	Netherlands	U.S.A.
France	South Africa, Rep. of	U.S.S.R.
Germany, F.R.	Spain	Yugoslavia

No member body expressed disapproval of the document.

Cinematography – Spindles for 8 mm Type S motion-picture projector reels/spools – Dimensions

1 SCOPE AND FIELD OF APPLICATION

This International Standard specifies the dimensions for 8 mm Type S motion-picture projector supply and take-up reel/spool spindles.

2 REFERENCES

ISO 1700, *Cinematography – 8 mm Type S motion-picture raw stock film – Cutting and perforating dimensions.*

ISO 3639, *Cinematography – Projection reels for 8 mm Type S motion-picture film – Dimensions and specifications.*

3 DIMENSIONS

3.1 The dimensions shall be as shown in the figure and given in the table.

3.2 The use of spindles in 8 mm projection equipment is not necessarily restricted to reels operating in the vertical mode. Because horizontal mode is possible, it is not necessary that the spindle protrude completely through the projection reel. Therefore, a reference dimension is supplied primarily for vertical mode design. When horizontal mode operation is considered, the minimum spindle length shall be governed by the minimum lug protrusion dimension B .

3.3 If the manufacturer desires to round, taper or point the end of the spindle, this may be done at his discretion, using any value needed for aesthetic or other design considerations; hence dimension E is optional.

3.4 The shape and amount, if any, of the extension of the drive lug beyond dimension B is optional with the manufacturer, provided that it does not exceed dimensions C and D .

3.5 A minimum spindle shoulder diameter is provided by dimension G . Good design practice would place any reel-locking device of the spindle outboard of the width of the projection reel at the spindle hole, possibly forcing the reel against the shoulder. The maximum for dimension G is intentionally less than the minimum diameter of the corresponding surface of the reel, to allow for run-out tolerances of both the spindle and reel, and for a loose fit of the reel on the spindle.

3.6 A radius is permitted on the drive lug equivalent to half its width (dimension F) in order to allow manufacturers to use a variety of construction methods or materials. The dimension D specified is for a drive lug with no radius (i.e. flat). Any radius (R_1) utilized by the manufacturer may be added to dimension D , so the maximum overall span of the spindle plus lug becomes $D + R_1$. The dimension $D + R_1$ should not exceed 16,2 mm (0.638 in).

3.7 The use of three driving lugs equally spaced at 120° around the spindle is not restricted by this International Standard. However, the width and height tolerances of the lug have not been adequately accounted for if such a design is incorporated. If the manufacturer chooses to utilize this approach, he is referred to 8 mm Type S projector reel specifications (see ISO 3639) to ensure adequate fit.

3.8 Unique spindle designs are not restricted by this International Standard. The use of three or more bearing surfaces can be allowed provided that they perform the same function as a cylinder of diameter A .

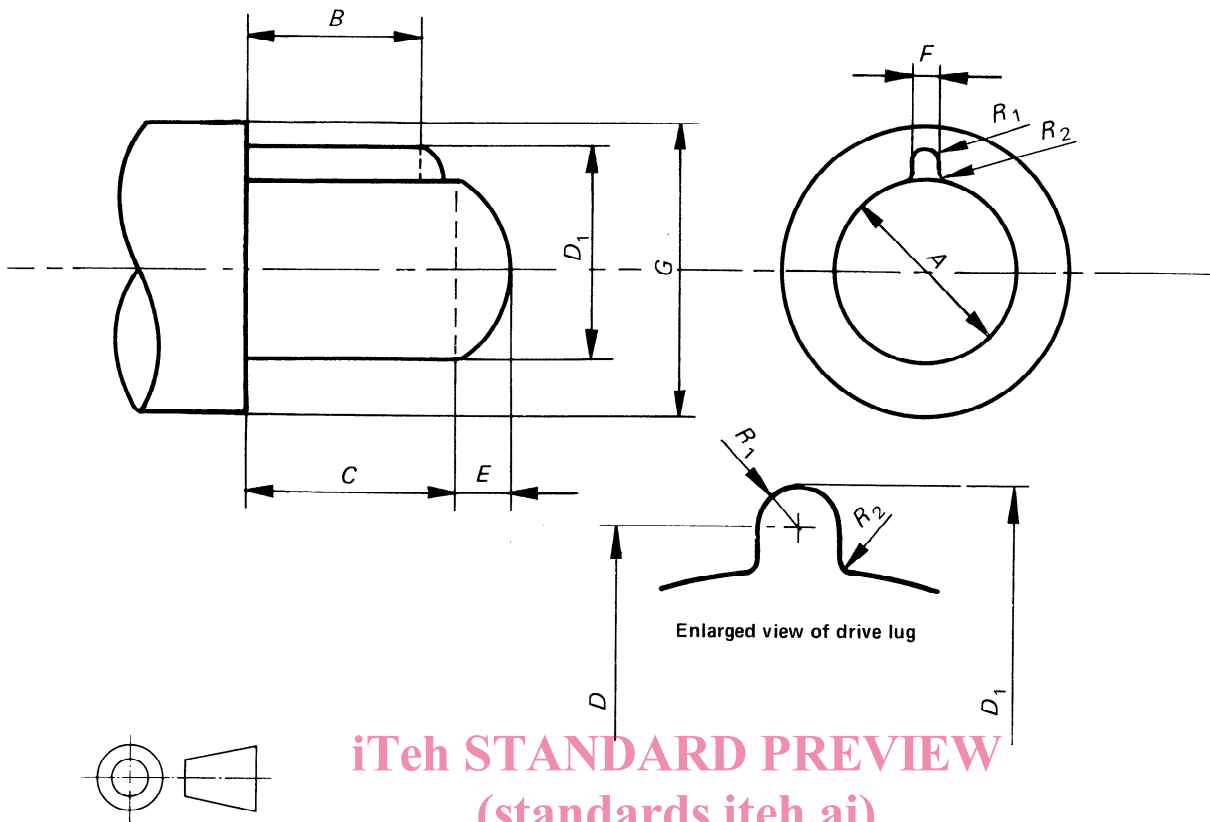

iTeh STANDARD PREVIEW
(standards.iteh.ai)

ISO 3653:1978

<https://standards.iteh.ai/catalog/standards/sist/0428c21b-61d2-4ddf-a076-ad5e55702fc/iso-3653-1978>

Dimension	mm	in
A (see 3.8)	12,70 ⁰ _{-0,25}	0.500 ⁰ _{-0.010}
B (see 3.2)	4,0 min.	0.16 min.
C (see 3.2)	14,0 ref.	0.55 ref.
D (see 3.6)	14,2 ^{+1,5} ₀	0.56 ^{+0.06} ₀
D ₁ (see 3.6)	16,2 max.	0,638 max.
E (see 3.3)	Optional	Optional
F	1,40 max.	0.055 max.
G	16,00 min. 24,50 max.	0.630 min. 0.965 max.
R ₁ (see 3.6)	0,7 max.	0.03 max.
R ₂	0,20 max.	0.008 max.