



Designation: ~~A503/A503M—01 (Reapproved 2011)~~ A503/A503M – 15

## Standard Specification for Ultrasonic Examination of Forged Crankshafts<sup>1</sup>

This standard is issued under the fixed designation A503/A503M; the number immediately following the designation indicates the year of original adoption or, in the case of revision, the year of last revision. A number in parentheses indicates the year of last reapproval. A superscript epsilon ( $\epsilon$ ) indicates an editorial change since the last revision or reapproval.

### 1. ~~Scope~~ Scope\*

1.1 This is an acceptance specification for the ultrasonic inspection of forged steel crankshafts having main bearing journals or crankpins 4 in. [100 mm] or larger in diameter.

1.2 This specification covers the testing equipment required and the test procedure to be followed, and it defines the critical and noncritical areas and limits of acceptance.

1.3 This specification is intended to cover both continuous grain flow (CGF) crankshafts for medium and high speed diesel engines as well as solid (slab) forged crankshafts for other applications.

1.4 The values stated in either inch-pound units or SI (metric) units are to be regarded separately as the standard. Within the text and tables, the SI units are shown in brackets. The values stated in each system shall be used independently of the other. Combining values from the two systems may result in nonconformance with the specification.

1.5 Unless the order specifies the applicable “M” specification designation, the inch-pound units shall be used.

1.6 *This standard does not purport to address all of the safety concerns, if any, associated with its use. It is the responsibility of the user of this standard to establish appropriate safety and health practices and determine the applicability of regulatory limitations prior to use.*

### 2. Referenced Documents

2.1 *ASTM Standards*:<sup>2</sup>

[A388/A388M Practice for Ultrasonic Examination of Steel Forgings](#)

[A788/A788M Specification for Steel Forgings, General Requirements](#)

[E428 Practice for Fabrication and Control of Metal, Other than Aluminum, Reference Blocks Used in Ultrasonic Testing](#)

2.2 *American National Standard*:<sup>3</sup>

[ANSI B46.1, Surface Texture](#)

### 3. Terminology

3.1 *Definitions*:

3.1.1 *continuous grain flow crankshafts*—produced by a process in which the solidification centerline of the original ingot or starting stock is maintained through the main bearings, webs, crankpins, and flanges of the finished crankshaft, usually by means of closed die forging.

3.1.2 *solid (slab) forged crankshafts*—made from open die forgings such that the grain flow in the webs is essentially parallel to the major axis of the forging and the crankpins are offset from the forging centerline by machining. They may be set in the correct orientation by a hot twisting operation.

### 4. Ordering Information

4.1 It is necessary that the crankshaft be identified as being either continuous grain flow or solid (slab) forged.

<sup>1</sup> This specification is under the jurisdiction of ASTM Committee A01 on Steel, Stainless Steel and Related Alloys and is the direct responsibility of Subcommittee A01.06 on Steel Forgings and Billets.

Current edition approved April 1, 2011; May 1, 2015. Published June 2011; May 2015. Originally approved in 1964. Last previous edition approved in 2006 (2011) as ~~A503/A503M—01/A503/A503M (2006)—01 (2011)~~. DOI: ~~10.1520/A0503\_A0503M-01R11-10.1520/A0503\_A0503M-15~~.

<sup>2</sup> For referenced ASTM standards, visit the ASTM website, [www.astm.org](http://www.astm.org), or contact ASTM Customer Service at [service@astm.org](mailto:service@astm.org). For *Annual Book of ASTM Standards* volume information, refer to the standard's Document Summary page on the ASTM website.

<sup>3</sup> Available from American National Standards Institute, 11 W. 42nd St., 13th Floor, New York, NY 10036-10036, <http://www.ansi.org>.

\*A Summary of Changes section appears at the end of this standard

4.2 Unless otherwise specified by means of supplementary ordering information, the test methods and acceptance criteria for the appropriate crankshaft type shall be used.

**5. Apparatus and Personnel Requirements**

5.1 The apparatus and personnel requirements shall be in accordance with Practice A388/A388M. For standardization purposes, it is recommended that final acceptance be based on the use of 2–5 MHz transducers.

**6. Critical Sections**

6.1 The division of a crankshaft into three volumetric zones, as shown in Fig. 1 and Fig. 2, for the purpose of ultrasonic examination evaluation is applicable to both solid (slab) forged and continuous grain flow crankshafts.

6.2 The major critical sections shown as Zone 1 in Fig. 1 include the heavily loaded areas of the crankpins, webs, and main bearings.

6.3 The minor critical sections shown as Zone 2 in Fig. 1 include the balance of the surface areas of the main bearing and crankpin journals and adjacent fillets, flanges, and gear fit areas.

6.4 The balance of the crankshaft as shown in Fig. 1, including the remaining sections of the webs, is included in Zone 3.

**7. Calibration of Ultrasonic Equipment on Crankshaft**

7.1 For solid (slab) forged crankshafts, the sensitivity of the instrument shall be adjusted so that the thickness to be examined will give a full-scale back reflection. Such calibrations shall be done in an area free of interfering indications.

7.2 For CGF crankshafts, 80 % of the full-scale back reflection is used when evaluating indications in accordance with Fig. 3.

**8. Procedure**

8.1 The crankshaft should be examined after heat treatment, but before machining geometric features such as chamfers and oil holes that could interfere with ultrasonic examination.

8.2 Unless otherwise specified by the purchase order, the scanned surfaces shall have a maximum surface roughness of 250 μin. [6.35 μm] where the definition for surface finish is as per Specification A788/A788M.

8.3 The crankshaft shall be scanned as shown in Fig. 2.

**9. Acceptance Criteria**

9.1 *Acceptance Zones:*

9.1.1 For acceptance purposes, the crankshaft shall be divided into three zones as shown in Fig. 1.

9.1.2 Because of crankshaft geometry, particularly for CGF crankshafts, the ultrasonic examination shall be carried out to the maximum extent possible.

9.2 *Solid Forged Crankshafts:*

9.2.1 In Zone 1, indications equal to or greater than 20 % of the back reflection as established in 7.1 shall be cause for rejection.

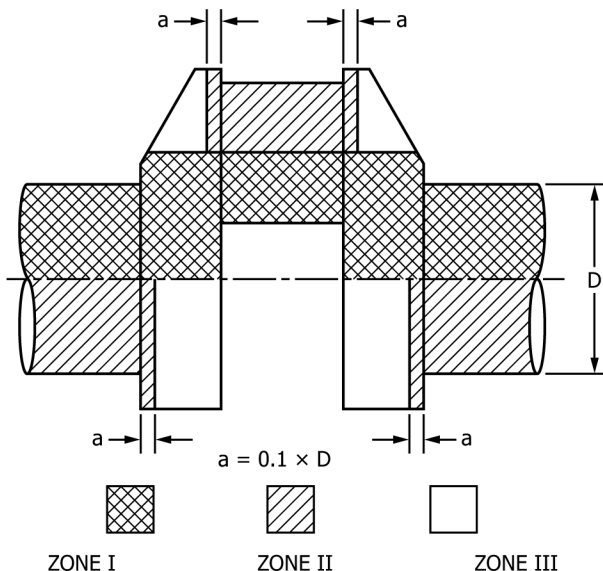

FIG. 1 Crankshaft UT Acceptance Zones