



Designation: **F914/F914M – 14 F914/F914M – 15**

# Standard Test Method for Acoustic Emission for Aerial Personnel Devices Without Supplemental Load Handling Attachments<sup>1</sup>

This standard is issued under the fixed designation F914/F914M; the number immediately following the designation indicates the year of original adoption or, in the case of revision, the year of last revision. A number in parentheses indicates the year of last reapproval. A superscript epsilon ( $\epsilon$ ) indicates an editorial change since the last revision or reapproval.

## 1. Scope

1.1 This test method describes a procedure for non-destructive testing using acoustic emission (AE) testing for aerial personnel devices, which do not have a supplemental load handling attachment.

1.1.1 *Equipment Covered*—This test method covers the following types of vehicle-mounted insulated aerial personnel devices:

- 1.1.1.1 Extensible boom aerial personnel devices,
- 1.1.1.2 Articulating boom aerial personnel devices, and
- 1.1.1.3 Any combination of 1.1.1.1 and 1.1.1.2.

1.1.2 *Equipment Not Covered*—This test method does not cover any of the following equipment:

- 1.1.2.1 Material-handling aerial devices,
- 1.1.2.2 Digger-derricks with platform, and
- 1.1.2.3 Cranes with platform.

1.2 The AE test method is used to detect and area-locate emission sources. Verification of emission sources may require the use of other nondestructive test (NDT) methods, such as radiography, ultrasonics, magnetic particle, liquid penetrant, and visual inspection. **Warning**—This test method requires that external loads be applied to the superstructure of the vehicle under test. During the test, caution must be taken to safeguard personnel and equipment against unexpected failure or instability of the vehicle or components.

NOTE 1—This test method is not intended to be a stand alone NDT method for the verification of the structural integrity of an aerial device. Other NDT methods should be used to supplement the results.

1.3 The values stated in either SI units or inch-pound units are to be regarded separately as standard. The values stated in each system may not be exact equivalents; therefore, each system shall be used independently of the other. Combining values from the two systems may result in non-conformance with the standard.

1.4 *This standard does not purport to address all of the safety concerns, if any, associated with its use. It is the responsibility of the user of this standard to establish appropriate safety and health practices and determine the applicability of regulatory limitations prior to use.*

## 2. Referenced Documents

2.1 *ASTM Standards*:<sup>2</sup>

- E94 Guide for Radiographic Examination
- E114 Practice for Ultrasonic Pulse-Echo Straight-Beam Contact Testing
- E164 Practice for Contact Ultrasonic Testing of Weldments
- E569 Practice for Acoustic Emission Monitoring of Structures During Controlled Stimulation
- E610 Terminology Relating to Acoustic Emission (Withdrawn 1991)<sup>3</sup>
- E650 Guide for Mounting Piezoelectric Acoustic Emission Sensors
- E750 Practice for Characterizing Acoustic Emission Instrumentation
- E976 Guide for Determining the Reproducibility of Acoustic Emission Sensor Response

<sup>1</sup> This test method is under the jurisdiction of ASTM Committee F18 on Electrical Protective Equipment for Workers and is the direct responsibility of Subcommittee F18.55 on Inspection and Non-Destructive Test Methods for Aerial Devices.

Current edition approved April 1, 2014 April 1, 2015. Published April 2014 May 2015. Originally approved in 1985. Last previous edition approved in 2014 as F914/F914M – 10: F914/F914M – 14. DOI: 10.1520/F0914\_F0914M-14.10.1520/F0914\_F0914M-15.

<sup>2</sup> For referenced ASTM standards, visit the ASTM website, www.astm.org, or contact ASTM Customer Service at service@astm.org. For *Annual Book of ASTM Standards* volume information, refer to the standard's Document Summary page on the ASTM website.

<sup>3</sup> Withdrawn. The last approved version of this historical standard is referenced on www.astm.org.

E1417/E1417M Practice for Liquid Penetrant Testing  
 E1444/E1444M Practice for Magnetic Particle Testing  
 F2174 Practice for Verifying Acoustic Emission Sensor Response

2.2 ANSI Standard:

ANSI A92.2 Standard for Vehicle-Mounted Elevating and Rotating Aerial Devices<sup>4</sup>

2.3 ASNT Standard:

ASNT Recommended Practice SNT-TC-1A<sup>5</sup>

### 3. Terminology

3.1 Definitions:

3.1.1 *acoustic emission (AE)*—the class of phenomena whereby elastic waves are generated by the rapid release of energy from a localized source or sources within a material, or the transient elastic wave(s) so generated. Acoustic emission is the recommended term for general use. Other terms that have been used in AE literature include stress wave emission, microseismic activity, and emission or acoustic emission with other qualifying modifiers.

3.1.2 *aerial personnel device*—any device extensible, articulating, or both, that is designed to position personnel.

3.1.3 *amplitude (acoustic emission signal amplitude)*—the peak voltage of the largest excursion attained by the signal wave form from an emission event.

3.1.4 *amplitude distribution*—a display of the number of acoustic emission events with signals that exceed an arbitrary amplitude as a function of amplitude.

3.1.5 *articulating-boom aerial device*—an aerial device with two or more hinged boom sections.

3.1.6 *attenuation*—loss of energy per unit distance.

3.1.7 *channel*—an input to the main AE instrument that accepts a preamplifier output.

3.1.8 *commoned*—two or more sensors interconnected such that the sensor outputs are electronically processed by a single channel without differentiation of sensor origin. (Synonym “teed”.)

3.1.9 *count (acoustic emission count), n*—the number of times the acoustic emission signal amplitude exceeds a preset threshold during any selected portion of a test.

3.1.10 *decibel (dB)*—logarithmic expression of a ratio of two single peak amplitudes. A reference scale expresses the logarithmic ratio of a single peak amplitude to a fixed reference amplitude.

$$\text{Signal peak amplitude (dB)} = 20 \log_{10} (A_1/A_0)$$

where:

$A_0$  = 1  $\mu$ V at the sensor output (before amplification), and

$A_1$  = peak voltage of the measured acoustic emission signal.

Acoustic Emission Reference Scale

dB Value	Voltage at Sensor Output	Voltage at Integral Preamp Sensor Output (40 dB gain)
0	1 $\mu$ V	100 $\mu$ V
20	10 $\mu$ V	1 mV
40	100 $\mu$ V	10 mV
60	1 mV	100 mV
80	10 mV	1 V
100	100 mV	10 V

3.1.11 *event (acoustic emission event)*.—a local material change giving rise to acoustic emission.

3.1.12 *event count (Ne)*—the number obtained by counting each discerned acoustic emission event once.

3.1.13 *extensible-boom aerial device*—an aerial device, except the aerial ladder type, with a telescopic or extensible boom.

3.1.14 *first-hit*—a mode of operation of AE monitoring equipment in which an event occurring on one channel will prevent all other channels from processing data for a specified period of time. The channel with a sensor closest to the physical location of the emission source will then be the only channel processing data from that source.

3.1.15 *insulated aerial device*—an aerial device designed with dielectric components to meet a specific electrical insulation rating.

3.1.16 *insulator*—any part of an aerial device such as, but not limited to, the upper boom, lower boom or supporting structure, made of a material having a high dielectric strength, usually FRP or the equivalent.

3.1.17 *noise*—any undesired signal that tends to interfere with the normal reception or processing of the desired signal.

<sup>4</sup> Available from American National Standards Institute (ANSI), 25 W. 43rd St., 4th Floor, New York, NY 10036, <http://www.ansi.org>.

<sup>5</sup> Available from American Society for Nondestructive Testing (ASNT), P.O. Box 28518, 1711 Arlington Ln., Columbus, OH 43228-0518, <http://www.asnt.org>.

3.1.18 *non-destructive testing*—the examination by various means of devices and their components without alteration of the original components, so that they may function as before.

3.1.19 *non-overcenter*—the feature of an aerial device where the upper boom cannot travel past vertical orientation with respect to the ground.

3.1.20 *overcenter*—the feature of an aerial device where the upper boom travels past vertical orientation with respect to the ground.

3.1.21 *qualified personnel*—personnel who, by possession of a recognized degree, certificate, professional standing, or skill, and who, by knowledge, training, and experience, have demonstrated the ability to deal with problems relating to the subject matter, the work, or the project.

3.1.22 *signal (emission signal)*—a signal obtained by detection of one or more acoustic emission events.

3.1.23 For definitions of other terms in this test method, refer to Terminology E610.

3.2 *Definitions of Terms Specific to This Standard* (see Figs. 1 and 2):

3.2.1 *elbow*—the structure connecting the upper boom to the lower boom, about which one articulates relative to the other.

3.2.2 *elbow pin*—the horizontal pin about which the upper boom rotates relative to the lower boom.

3.2.3 *lift cylinder*—The hydraulic cylinder that lifts the lower boom and the extensible boom(s).

3.2.4 *lower boom*—the structural member, attached to a turntable or base, that supports the upper boom.

3.2.5 *lower boom cylinder*—the hydraulic cylinder that articulates the lower boom.

3.2.6 *lower boom insulator*—the part of the lower boom made of high dielectric strength material (usually fiberglass reinforced plastic or equivalent).

3.2.7 *lower boom pin*—the horizontal pin about which the lower boom is raised and lowered relative to the turntable.

3.2.8 *outriggers*—the structural members that, when properly extended or deployed on firm ground, assist in stabilizing the vehicle on which the aerial device is mounted.

ITEH Standards  
(<https://standards.iteh.ai>)  
Document Preview

<https://standards.iteh.ai/catalog/standards/sist/843f62d3-79f6-4008-9c8e5189c1b2/astm-f914-f914m-15>

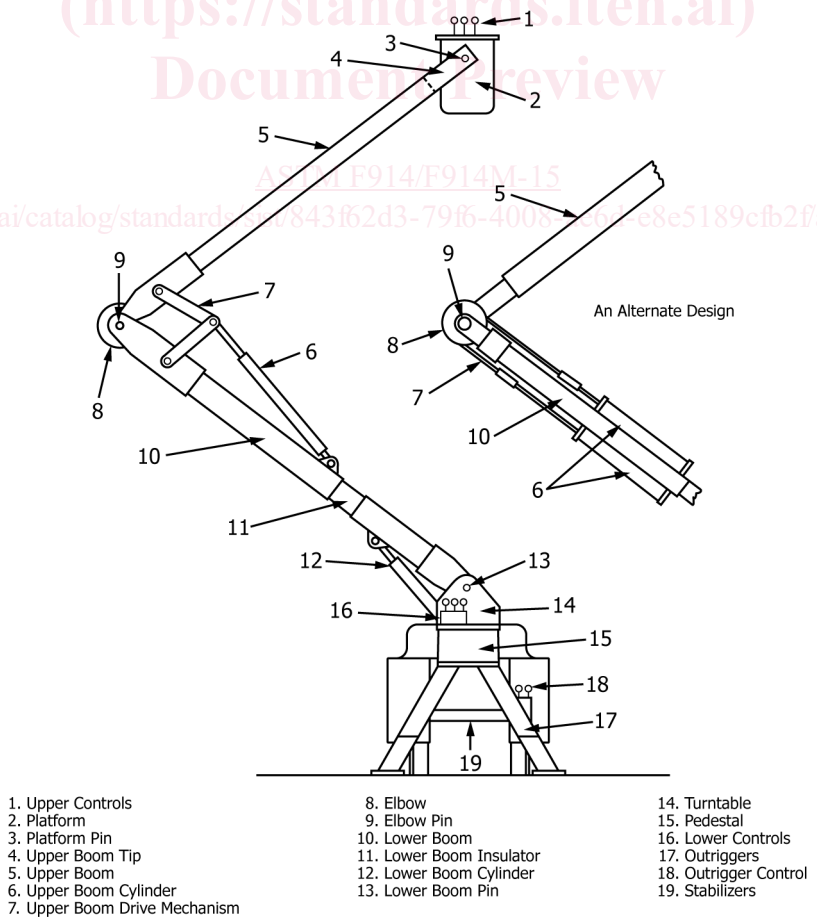

- |                               |                          |                       |
|-------------------------------|--------------------------|-----------------------|
| 1. Upper Controls             | 8. Elbow                 | 14. Turntable         |
| 2. Platform                   | 9. Elbow Pin             | 15. Pedestal          |
| 3. Platform Pin               | 10. Lower Boom           | 16. Lower Controls    |
| 4. Upper Boom Tip             | 11. Lower Boom Insulator | 17. Outriggers        |
| 5. Upper Boom                 | 12. Lower Boom Cylinder  | 18. Outrigger Control |
| 6. Upper Boom Cylinder        | 13. Lower Boom Pin       | 19. Stabilizers       |
| 7. Upper Boom Drive Mechanism |                          |                       |

FIG. 1 Articulating Aerial Device Nomenclature Diagram

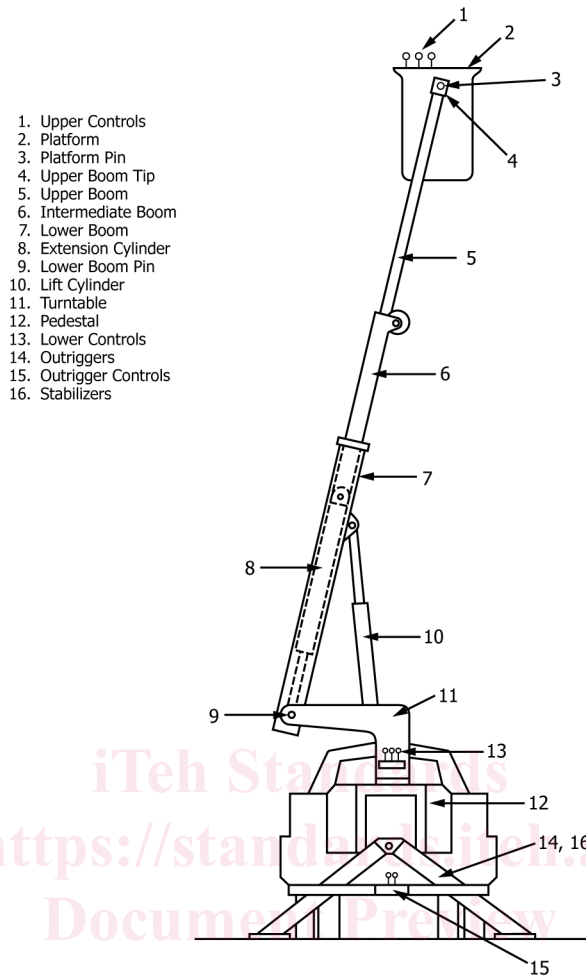

FIG. 2 Extensible Aerial Device Nomenclature Diagram

<https://standards.iteh.ai/catalog/standards/sist/843f62d3-79f6-4008-ae6d-e8e5189c1b2f/astm-f914-f914m-15>

3.2.9 *pedestal*—the stationary base of the aerial device that supports the turntable.

3.2.10 *platform*—the personnel-carrying component of an aerial device, such as a bucket, basket, stand, or equivalent.

3.2.11 *platform pin*—the horizontal pin about which the platform rotates relative to the upper boom.

3.2.12 *rated platform capacity*—The maximum load as stated by the manufacturer for which an aerial device is designed to operate, consisting of the combined weight of the personnel and all items carried on or in the platform.

3.2.13 *stabilizers*—a means to assist in stabilizing the vehicle, such as outriggers, torsion bars, and spring lockouts.

3.2.14 *supplemental load-handling attachment (Jib)*—a device(s) affixed to the upper-boom tip area which is designed to lift and or position materials.

3.2.15 *turntable*—the rotating base of the aerial device that supports the booms.

3.2.16 *upper boom*—the structural member, attached to the lower boom, that supports the platform.

3.2.17 *upper boom cylinder*—the hydraulic cylinder that articulates the upper boom.

3.2.18 *upper boom drive mechanism*—means, such as linkage, cables, sheaves and gears, used to produce upper boom articulation.

3.2.19 *upper boom tip*—the end of the upper boom to which the platform is attached.

#### 4. Summary of Test Method

4.1 This test method consists of applying a predetermined load to an aerial personnel device while it is being monitored by sensors that are sensitive to acoustic emissions (AE) caused by active defects. These acoustic emissions can be generated by, but are not limited to, the following: crack nucleation movement or propagation in the metal components; or matrix crazing, de-lamination or fiber breakage of the fiberglass reinforced plastic (FRP) material; or both.

4.2 The aerial personnel device is loaded at a uniform rate until a predetermined load is reached, which is held for a period of time. The load is removed and the cycle is repeated. Acoustic emissions are monitored during both cycles and the data are evaluated.

4.3 The test load used during an acoustic emission test on an aerial personnel device shall be two times the rated platform capacity.

## 5. Significance and Use

5.1 This test method provides a means of evaluating acoustic emissions generated by the rapid release of energy from localized sources within an aerial personnel device under controlled loading. The resultant energy releases occur during intentional application of a controlled predetermined load. These energy releases can be monitored and interpreted by qualified individuals.

5.2 This test method permits testing of the major components of an aerial personnel device under controlled loading. This test method utilizes objective criteria for evaluation and may be discontinued at any time to investigate a particular area of concern or prevent a fault from continuing to ultimate failure.

5.3 This test method provides a means of detecting acoustic emission sources that may be defects or irregularities, or both, affecting the structural integrity or intended use of the aerial personnel device.

5.4 Sources of acoustic emission found with this test method shall be evaluated by either more refined acoustic emission test methods or other nondestructive techniques (visual, liquid penetrant, radiography, ultrasonics, magnetic particle, etc.). Other nondestructive tests may be required to locate defects present in aerial personnel devices.

5.5 Defective areas found in aerial personnel devices by this test method should be repaired and retested as appropriate. Repair procedure recommendations are outside the scope of this test method.

## 6. Personnel Qualifications

6.1 This test method shall be performed by qualified personnel. Qualification shall be in accordance with an established written program, consistent with the established format of ASNT SNT-TC-IA for training, qualification, and certification of personnel for conducting AE testing of aerial personnel devices.

NOTE 2—Personnel performing subsequent nondestructive evaluation (visual, liquid penetrant, radiography, ultrasonic, magnetic particle, etc.) on aerial devices shall be certified in accordance with ASNT SNT-TC-IA guidelines.

6.2 Acoustic emission test personnel shall be familiar with the design, manufacture, and operation of aerial personnel devices. Relevant information is contained in ANSI A92.2 and manufacturers' operating and service manuals.

## 7. Acoustic Emission Instrumentation

7.1 The AE instrument shall be capable of data acquisition in discrete channels within a frequency band of 20 to 200 kHz. The number of AE instrument channels shall be determined by the attenuation characteristics of the aerial device in order to provide coverage of those components identified in **Table 1**. A detailed description of instrumentation characteristics is included in **Annex A1**.

NOTE 3—Experience has shown that a minimum of eight channels of data acquisition is required. The instrument should be capable of recording the following: time, events, counts, amplitude and load. Hard copy records shall be provided by the instrument or available through a direct interface.

NOTE 4—A maximum of two sensors may be commoned on any one channel.

**TABLE 1 Aerial Device Components That Shall Be Monitored With Acoustic Emission**

Component <sup>A</sup>	Articulated Aerial Device	Extensible Aerial Device
Platform	X <sup>B</sup>	X
Platform attachment	X	X
Upper Boom	X	X
Lower boom insulator	X	X
Intermediate boom	X	X
Upper and lower boom attachment of elbow	X	X <sup>B</sup>
Upper and lower section of lower boom	X	NA <sup>C</sup>
Turntable	X	X
Pedestal	X	X

<sup>A</sup> Refer to **Figs. 1 and 2** for illustration of components.

<sup>B</sup> The use of the symbol "X" indicates the requirement to monitor this component with acoustic emission.

<sup>C</sup> The use of the symbol "NA" indicates that acoustic emission does not apply.

## 8. Test Preparation

8.1 Prior to the AE test, perform a visual observation of the aerial lift device to ensure that the components to be tested are free from any condition that may prohibit the test or adversely affect test results.

8.2 The components to be monitored in an aerial personnel device shall include but not be limited to those specified in **Table 1**. Additional channels and sensors may be used to supplement the minimum test requirements and improve location resolution.

8.3 Position the sensors on the FRP and metal portions of the components identified in **Table 1**. The extent of the coverage is determined by the number of sensors used and the attenuation characteristics of the individual components, and can be verified by a simulated AE technique as indicated in Guide **E976**. Record the amplitude of the simulated AE source at a distance of 12 in. (304 mm) from the sensor as a reference. Continue to move the simulated AE source away from the sensor until the amplitude is no more than 15 dB less than the reference amplitude. This will establish the maximum area of coverage of the sensor.

8.4 The mounting of sensors shall be in accordance with Practices **E569** and **E650**. The couplant used shall not affect the performance of the aerial device.

NOTE 5—The couplant should be compatible with the aerial device, not a possible cause of contamination. The couplant should be completely removable from the surface after testing, leaving the original surface intact.

## 9. AE Instrumentation System Performance Check

9.1 Make performance verification of the AE system performance with an AE simulator immediately prior to application of test load. This simulator should be capable of producing a transient elastic wave having an amplitude representative of the AE signals to be recorded.

9.2 The AE simulator may be gas jet, pencil lead break technique or an electronically induced event or equivalent.

9.3 The detected peak amplitude of the simulated event at a fixed distance, typically 6 to 9 in. [152 to 228 mm], from each sensor shall not vary more than 6 dB from the average of all the sensors on the same type material. The detected peak amplitude of any sensor shall not exceed 90 dB to avoid saturation of amplifier(s).

9.4 A sensor performance check should be performed periodically in accordance with Practice **F2174**.

## 10. System Calibration

10.1 Subject the AE system to a thorough calibration and functional check to verify accurate performance in accordance with the manufacturer's specification, in conjunction with Practice **E750**. Perform calibration annually as a minimum in accordance with a written calibration procedure. Include in the calibration, as a minimum: calibration of threshold levels, amplitude measurement circuits, count measurement circuits, AE sensors, and load measuring devices.

10.2 Subject the AE system to a routine performance check, which shall include as a minimum, verification of threshold levels and amplitude measurements.

## 11. Procedure

11.1 Test articulating aerial personnel devices in positions such that the components indicated in **Table 1** can be monitored. The recommended test positions as illustrated in **Fig. 3** or their equivalents may be used.

11.2 Test extensible aerial personnel devices in positions such that the components indicated in **Table 1** can be monitored. Recommended test position as illustrated in **Fig. 4** or its equivalent may be used.

11.3 Attach the load measuring device to the load application system which in turn shall be attached to an adequate dead weight or anchor.

11.4 Recommended load attachment points are shown in **Figs. 5 and 6**. The method of load application and attachment shall evenly distribute the load and shall not permanently deform the platform.

11.5 The load connection technique used should simulate in-field use as closely as possible.

NOTE 6—Attach the load system to the bucket or platform so that the centerline of load application passes through Point(s) A-1. On units with two platforms, distribute the load evenly to both platforms or buckets.

NOTE 7—On units with platform rotators, the platform(s) shall be rotated until the centerline of the load application is at the maximum distance beyond the platform pin.

11.6 The test load employed at the points illustrated in **Figs. 5 and 6** shall be two times the rated platform capacity.

11.7 All components of the load application system shall be capable of supporting the test load.

11.8 Perform the loading sequence as illustrated in **Fig. 7**.

11.9 As a minimum, record the following data during the test:

11.9.1 Events by channel (events versus time),

11.9.2 Counts versus time or load for metal channels,