



Designation: ~~D4423~~ – ~~10~~ D4423 – 10 (Reapproved 2015)

Standard Test Method for Determination of Carbonyls in C₄ Hydrocarbons¹

This standard is issued under the fixed designation D4423; the number immediately following the designation indicates the year of original adoption or, in the case of revision, the year of last revision. A number in parentheses indicates the year of last reapproval. A superscript epsilon (ϵ) indicates an editorial change since the last revision or reapproval.

1. Scope

1.1 This test method covers the determination of carbonyls (ketones and aldehydes) in C₄ hydrocarbons. This test method was tested on polymerization-grade 1,3-butadiene.

1.2 The applicable range for this test method is 00 mg/kg to 50 mg/kg carbonyls calculated as acetaldehyde.

1.3 Other C₄ hydrocarbons and their mixtures besides polymerization-grade 1,3-butadiene could be tested using this same test method. However, the precision section of this test method covers only carbonyls in applicable range as listed in 1.2, as found in polymerization-grade 1,3-butadiene.

1.4 **WARNING**—Mercury has been designated by many regulatory agencies as a hazardous material that can cause central nervous system, kidney and liver damage. Mercury, or its vapor, may be hazardous to health and corrosive to materials. Caution should be taken when handling mercury and mercury containing products. See the applicable product Material Safety Data Sheet (MSDS) for details and EPA's website—<http://www.epa.gov/mercury/faq.htm>—for additional information. Users should be aware that selling mercury and/or mercury containing products into your state or country may be prohibited by law.

1.5 The values stated in SI units are to be regarded as standard. No other units of measurement are included in this standard.

1.6 *This standard does not purport to address all of the safety concerns, if any, associated with its use. It is the responsibility of the user of this standard to establish appropriate safety and health practices and determine the applicability of regulatory limitations prior to use.*

2. Referenced Documents

2.1 *ASTM Standards*:²

[D484 Specification for Hydrocarbon Dry Cleaning Solvents](#) (Withdrawn 1982)³

[D1193 Specification for Reagent Water](#)

[E1 Specification for ASTM Liquid-in-Glass Thermometers](#)

<https://standards.iteh.ai/catalog/standards/sist/28b1f671-8f4c-4103-af66-41d57434499d/astm-d4423-102015>

3. Summary of Test Method

3.1 A measured amount of sample is added to an alcoholic hydroxylamine hydrochloride solution that has been adjusted to a given coloration using either alcoholic acid or base. The carbonyls will react with the hydroxylamine hydrochloride releasing an equivalent amount of hydrochloric acid which is then back-titrated to the original coloration. A blank containing only methanol and sample is titrated and the sample's results are calculated using the blank adjustment. Results are reported as milligrams per kilogram carbonyls as acetaldehyde.

4. Significance and Use

4.1 The determination of the carbonyl content of polymerization-grade 1,3-butadiene is necessary, since in some polymerization reactions, the presence of carbonyls in excess over some specified amount can have a deleterious effect upon the polymer properties or the reaction itself, or both.

¹ This test method is under the jurisdiction of ASTM Committee [D02](#) on Petroleum ~~Products~~—Products, Liquid Fuels, and Lubricants and is the direct responsibility of Subcommittee [D02.D0.04](#) on C4 Hydrocarbons.

Current edition approved ~~May 1, 2010~~ April 1, 2015. Published ~~June 2010~~ May 2015. Originally approved in 1984. Last previous edition approved in ~~2006~~ 2010 as ~~D4423-00(2006)~~ D4423 – 10. DOI: ~~10.1520/D4423-10.1520/D4423-10R15~~.

² For referenced ASTM standards, visit the ASTM website, www.astm.org, or contact ASTM Customer Service at service@astm.org. For *Annual Book of ASTM Standards* volume information, refer to the standard's Document Summary page on the ASTM website.

³ The last approved version of this historical standard is referenced on www.astm.org.

5. Apparatus

5.1 *Bunsen Valves*—A device constructed so that when used with an Erlenmeyer flask, the sample vapors can exit the flask while protecting the flask's liquid contents. See Fig. 1 for details.

5.2 *Cooling Coil*—Prepare a cooling coil by winding about ~~10~~ 10 cm to 15 cm of seamless copper tubing (about ~~6 mm~~ 6 mm diameter) on a short length of pipe (about ~~1.5 cm to 2.0 cm~~ 1.5 cm to 2.0 cm diameter), allowing sufficient length of tubing at the end of the coil to connect it to the sample source. Attach a valve at a point that would not extend more than ~~8 cm~~ 8 cm above the surface of the cooling bath liquid. To the valve, attach a ~~66 cm to 8 cm~~ 66 cm to 8 cm length piece of tubing bent downward so that the hydrocarbon liquid can be directed into the receiving container.

5.3 *Dewar Flask*—The Dewar flask must be of sufficient volume to completely immerse the main portion of the cooling coil except for the extremities necessary for receiving and delivering the sample through the coil.

5.4 *Erlenmeyer Flasks*, ~~250 mL~~ 250 mL capacity.

5.5 *Volumetric Flasks*, ~~1 L~~ 1 L capacity. These flasks should be Class A glassware.

5.6 *Graduated Cylinders*—~~100 mL~~ 100 mL capacity, glass cylinders, graduated in ~~1 mL~~ 1 mL or ~~2 mL~~ 2 mL divisions.

5.7 *Microburets*, ~~2.00 mL~~ 2.00 mL or ~~5.00 mL~~ 5.00 mL capacity. The microburets should be Class A glassware with ~~0.01 mL~~ 0.01 mL or ~~0.02 mL~~ 0.02 mL divisions or less. It is advisable to have the buret's tip end equipped with a syringe needle to dispense very small drops of titrant.

5.8 *Sample Cylinders*—These should be of sufficient volume to give the required amount of sample for testing. Stainless steel cylinders equipped with needle valves should be used. It is suggested that a ~~500 mL-capacity~~ 500 mL-capacity cylinder be the minimum size to be used for butadiene.

5.9 *Thermometer*—For observing temperatures below ~~45°C~~ 45 °C. The Low Cloud and Pour Point Thermometer, conforming to the requirements for ASTM Thermometer 6C, as prescribed in Specification E1, is satisfactory. Thermometer 6C has a range from ~~80°C to +20°C~~ 80 °C to +20 °C. Temperature measuring devices that cover the temperature range of interest, such as the ASTM 1C thermometer, or liquid-in-glass thermometers, thermocouples, or platinum resistance thermometers that provide equivalent or better accuracy and precision may be used.

6. Reagents and Materials

6.1 *Purity of Reagents*—Reagent grade chemicals should be used in all tests. Unless otherwise indicated, it is intended that all reagents conform to the specifications of the Committee on Analytical Reagents of the American Chemical Society where such specifications are available.⁴ Other grades may be used, provided it is first ascertained that the reagent is of sufficiently high purity to permit its use without lessening the accuracy of the determination.

6.2 *Purity of Water*—Unless otherwise indicated, references to water shall be understood to mean Type II reagent water conforming to Specification D1193.

⁴ *Reagent Chemicals, American Chemical Society Specifications*, American Chemical Society, Washington, DC. For suggestions on the testing of reagents not listed by the American Chemical Society, see *Analar Standards for Laboratory Chemicals*, BDH Ltd., Poole, Dorset, U.K., and the *United States Pharmacopeia and National Formulary*, U.S. Pharmacopeial Convention, Inc. (USPC), Rockville, MD.

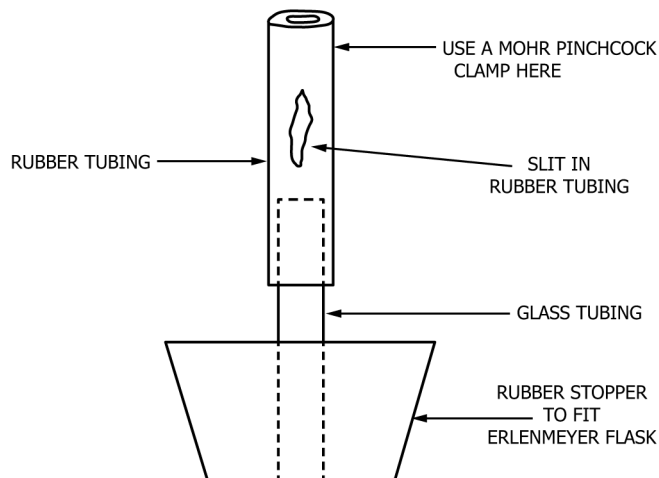

FIG. 1 Apparatus