



Designation: D4893 – 94 (Reapproved 2015)^{ε1}

Standard Test Method for Determination of Pitch Volatility¹

This standard is issued under the fixed designation D4893; the number immediately following the designation indicates the year of original adoption or, in the case of revision, the year of last revision. A number in parentheses indicates the year of last reapproval. A superscript epsilon (ϵ) indicates an editorial change since the last revision or reapproval.

^{ε1} NOTE—SI units formatting was corrected editorially in May 2015.

1. Scope

1.1 This test method covers the determination of the percent of pitch volatility.

1.2 Since this test method is empirical, strict adherence to the procedure is necessary.

1.3 The values stated in SI units are to be regarded as the standard. The values in parentheses are given for information only.

1.3.1 *Exceptions*—The diameter of a special aluminum block is measured in inches.

1.4 *This standard does not purport to address all of the safety concerns, if any, associated with its use. It is the responsibility of the user of this standard to establish appropriate safety and health practices and determine the applicability of regulatory limitations prior to use.*

2. Summary of Test Method

2.1 An aluminum weighing dish with about 15 g of specimen is introduced into the cavity of a metal block heated and maintained at 350 °C (662 °F). After 30 min \pm 10 s during which the volatiles are swept away from the surface of the liquid pitch by preheated nitrogen, the sample is taken out and allowed to cool down in the desiccator. The pitch volatility is determined by the sample weight loss and reported as percent weight loss.

3. Significance and Use

3.1 This test is useful in evaluating and characterizing pitch physical properties in comparing the consistency of shipments and sources of supply.

¹ This test method is under the jurisdiction of ASTM Committee D02 on Petroleum Products, Liquid Fuels, and Lubricants and is the direct responsibility of Subcommittee D02.05 on Properties of Fuels, Petroleum Coke and Carbon Material.

Current edition approved April 1, 2015. Published May 2015. Originally approved in 1989. Last previous edition approved in 2009 as D4893 – 94 (2009). DOI: 10.1520/D4893-94R15E01.

4. Apparatus

4.1 *Aluminum Block*,² 4½ in. outside diameter, composed of two sections (Figs. 1-4).

4.1.1 The top block is maintained at a chosen constant temperature according to the signal from the thermocouple inserted into the thermowell No. 1 near the center of the block. A proportional temperature controller regulates the heat input. Two insulated handles are attached to this part for easy handling. An additional thermowell No. 2, located in the center of the block, accommodates another thermocouple used only for the determination of the rate of temperature rise of the pitch. When the screw at the bottom of the No. 2 well is taken out, the thermocouple can then be pushed down and inserted in pitch.

4.1.2 The bottom block has a cavity for the aluminum weighing dish. A spiral channel cut around the periphery of this part serves for preheating the nitrogen introduced at the measured rate (10 cm³/min) into the block for purging volatiles.

4.1.3 The test temperature, the same as that in the top block, is maintained by the second proportional temperature controller according to the signals of a thermocouple inserted in a thermowell No. 3 of the bottom block. There is a hole in the center of the bottom cylinder to accommodate the sample platform, a rod with a stainless steel disk welded to its top. The aluminum sample dish containing the sample rests on top of this disk during the test. The aluminum sample dish can be lifted out of the cavity by raising the disk up to the upper rim of the cavity.

4.2 *Aluminum Weighing Dish*.

4.3 *Flowmeter*, 0 cm³/min to 25 cm³/min range.

² An aluminum block that may be obtained on special order from Koppers Company, Inc., 1005 Wm. Pitt Way, Pittsburgh, PA 15238, has been found satisfactory for this purpose; or drawings of block will be furnished by Koppers upon request. If you are aware of alternative suppliers, please provide this information to ASTM International Headquarters. Your comments will receive careful consideration at a meeting of the responsible technical committee,¹ which you may attend.

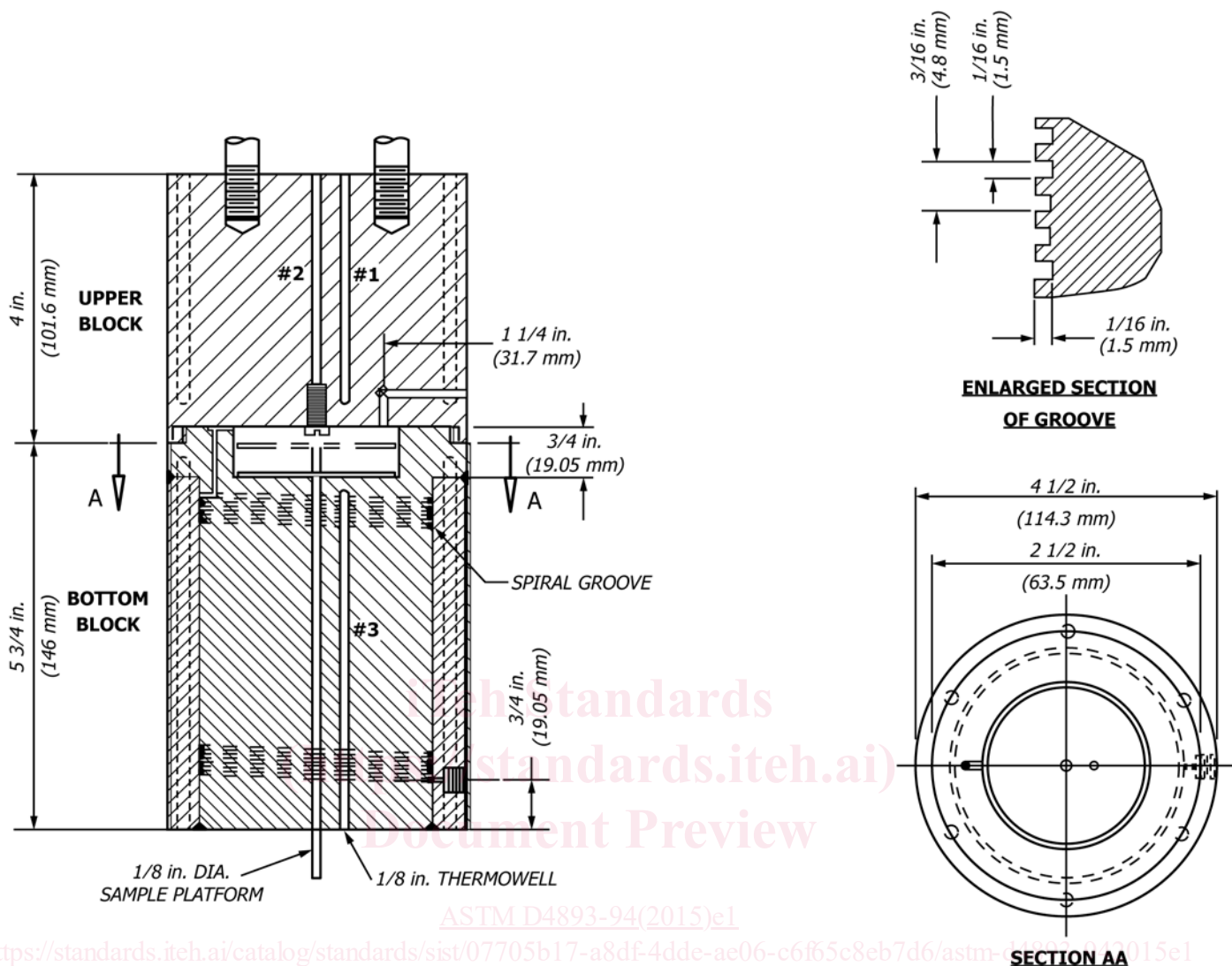

FIG. 1 Schematic of the Volatility Apparatus

4.4 *Nitrogen Cylinder*, equipped with a pressure regulator.

4.5 *Timer*, with an alarm.

4.6 *Aluminum Plate*, 127 mm by 127 mm, approximately 20-gauge.

5. Dehydration of Sample

5.1 *Hard Pitch*—If the solid bulk sample contains free water, air-dry a representative portion in a forced-draft oven at 50 °C (122 °F).

5.2 *Soft Pitch (Softening Point <60 °C (<140 °F))*—If the presence of water is indicated by surface foam on heating, maintain a representative portion of the bulk sample at a temperature between 125 °C and 150 °C (251 °F and 302 °F) in an open container until the surface is free of foam. Take care not to overheat, and remove heat source immediately when foam subsides.

6. Preparation of Working Sample

6.1 Crush sample to pass No. 4 mesh (4760 μm).

7. Preparation of Apparatus

7.1 Assemble the apparatus so that the exit opening in the upper block is aligned with bottom nitrogen inlet fitting of the bottom block. Both top and bottom blocks are heated to the test temperature, 350 °C (662 °F), using the proportional temperature controllers. *Avoid* heating the upper block and lower block when separated from each other.

8. Procedure

8.1 Weigh 15 g of prepared sample into a tared aluminum weighing dish with precision of 0.1 mg.

8.2 Start nitrogen purge system at a rate 10 cm³/min ± 0.1 cm³/min (10 mL/min ± 0.1 mL/min).

8.3 Place top block onto bottom block, align the nitrogen inlet with nitrogen outlet, and heat to test temperature of 350 °C (662 °F).

8.4 Remove top block. Raise the sample platform up slightly above the rim of heating cavity and support with the aluminum plate inserted between the sample platform and top

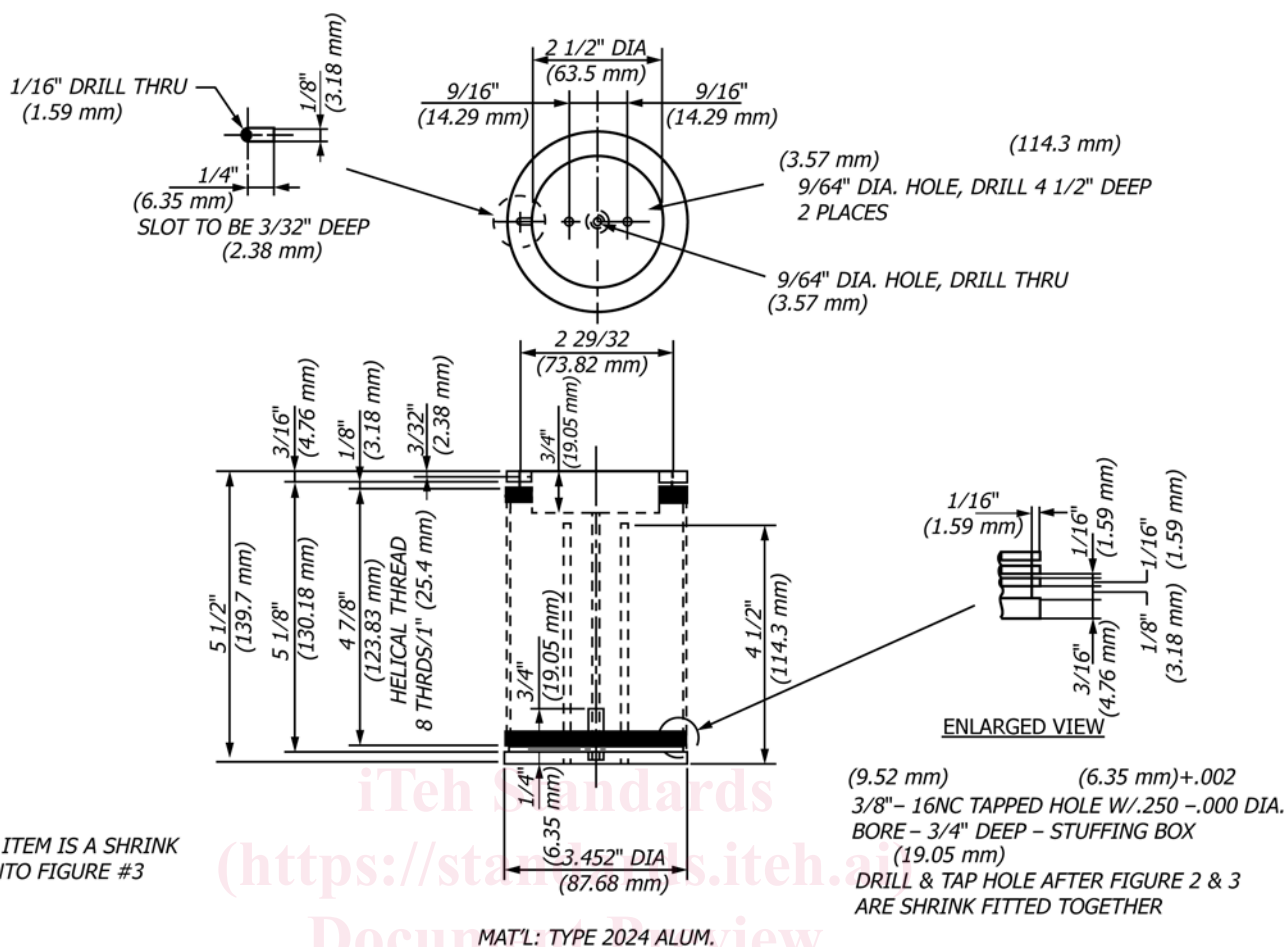

FIG. 2 Internal Schematic Lower Block

rim of the bottom block. Place the aluminum sample dish containing the sample onto the sample platform. Remove the inserted aluminum plate from below the sample platform and lower the sample carefully into the heated cavity. Close the bottom block with the top block and realign the nitrogen inlet with nitrogen outlet. This operation should be performed as quickly as possible to avoid excessive heat loss from the heated cavity.

8.5 Heat for 30 min ± 10 s. Remove top block, raise sample platform, insert aluminum plate under the sample platform, sweep the sample off the sample platform on to the plate, and set aside.

8.6 Close the bottom block with the top block, realign the nitrogen inlet and outlet and allow the temperature in the blocks to stabilize before inserting subsequent sample.

8.7 When sample has cooled, approximately 2 min after removal or when crust has formed on top of sample, set aluminum dish containing sample into desiccator for 30 min. Determine weight loss.

8.8 Report in percent, mass loss for test temperature, 350 °C.

$$V = (b \times 100)/a \quad (1)$$

where:

V = volatility, percent, mass loss,

b = mass loss, g, and

a = net mass of sample, g.

8.9 The exit opening of nitrogen purge, the sample platform, and the seat between the blocks must be kept free of deposits. For cleaning use acetone and a drill bit for opening the nitrogen exit.

9. Determination of Unit Heat-up Rate

9.1 The volatility test temperature should be maintained at the same level for the total duration of the test. Because this is not possible, the required temperature level should be reached within the shortest time after placing the sample into the preheated blocks. *The heat-up rate is determined with a selected control pitch sample.* The temperature of pitch is measured and recorded with the provided thermocouple and a separate temperature indicator (not provided). For that reason the thermocouple is introduced through the upper block after removing the closing screw and its immersion in the pitch sample is adjusted so that it is covered with pitch but does not touch the bottom of the aluminum weighing dish.

9.2 The procedure for preheating the blocks and introducing the pitch sample into the cavity of the volatility apparatus is identical to the actual volatility procedure.