



Designation: **D6671/D6671M – 13 D6671/D6671M – 13^{ε1}**

Standard Test Method for Mixed Mode I-Mode II Interlaminar Fracture Toughness of Unidirectional Fiber Reinforced Polymer Matrix Composites¹

This standard is issued under the fixed designation D6671/D6671M; the number immediately following the designation indicates the year of original adoption or, in the case of revision, the year of last revision. A number in parentheses indicates the year of last reappraisal. A superscript epsilon (ϵ) indicates an editorial change since the last revision or reappraisal.

^{ε1} NOTE—Characters in equations 2, 3, 10, 12, 13, and 17–21 corrected editorially in May 2015.

1. Scope

1.1 This test method describes the determination of interlaminar fracture toughness, G_c , of continuous fiber-reinforced composite materials at various Mode I to Mode II loading ratios using the Mixed-Mode Bending (MMB) Test.

1.2 This test method is limited to use with composites consisting of unidirectional carbon fiber tape laminates with brittle and tough single-phase polymer matrices. This test method is further limited to the determination of fracture toughness as it initiates from a delamination insert. This limited scope reflects the experience gained in round robin testing. This test method may prove useful for other types of toughness values and for other classes of composite materials; however, certain interferences have been noted (see Section 6). This test method has been successfully used to test the toughness of both glass fiber composites and adhesive joints.

1.3 The values stated in either SI units or inch-pound units are to be regarded separately as standard. The values stated in each system may not be exact equivalents; therefore, each system shall be used independently of the other. Combining values from the two systems may result in non-conformance with the standard.

1.4 *This standard does not purport to address all of the safety concerns, if any, associated with its use. It is the responsibility of the user of this standard to establish appropriate safety and health practices and determine the applicability of regulatory limitations prior to use.*

2. Referenced Documents

2.1 ASTM Standards:²

[D883 Terminology Relating to Plastics](#)

[D2651 Guide for Preparation of Metal Surfaces for Adhesive Bonding](#)

[D2734 Test Methods for Void Content of Reinforced Plastics](#)

[D3171 Test Methods for Constituent Content of Composite Materials](#)

[D3878 Terminology for Composite Materials](#)

[D5229/D5229M Test Method for Moisture Absorption Properties and Equilibrium Conditioning of Polymer Matrix Composite Materials](#)

[D5528 Test Method for Mode I Interlaminar Fracture Toughness of Unidirectional Fiber-Reinforced Polymer Matrix Composites](#)

[E4 Practices for Force Verification of Testing Machines](#)

[E6 Terminology Relating to Methods of Mechanical Testing](#)

[E122 Practice for Calculating Sample Size to Estimate, With Specified Precision, the Average for a Characteristic of a Lot or Process](#)

[E177 Practice for Use of the Terms Precision and Bias in ASTM Test Methods](#)

[E456 Terminology Relating to Quality and Statistics](#)

¹ This test method is under the jurisdiction of ASTM Committee D30 on Composite Materials and is the direct responsibility of Subcommittee D30.06 on Interlaminar Properties.

Current edition approved Oct. 1, 2013. Published November 2013. Originally approved in 2001. Last previous edition approved in 2006 as D6671/D6671M – 06. DOI: 10.1520/D6671-D6671M-13-10.1520/D6671-D6671M-13E01.

² For referenced ASTM standards, visit the ASTM website, www.astm.org, or contact ASTM Customer Service at service@astm.org. For *Annual Book of ASTM Standards* volume information, refer to the standard's Document Summary page on the ASTM website.

3. Terminology

3.1 Terminology **D3878** defines terms relating to high-modulus fibers and their composites. Terminology **D883** defines terms relating to plastics. Terminology **E6** defines terms relating to mechanical testing. Terminology **E456** and Practice **E177** define terms relating to statistics. In the event of conflict between terms, Terminology **D3878** shall have precedence over the other terminology standards.

NOTE 1—If the term represents a physical quantity, its analytical dimensions are stated immediately following the term (or letter symbol) in fundamental dimension form, using the following ASTM standard symbology for fundamental dimensions, shown within square brackets: $[M]$ for mass, $[L]$ for length, $[T]$ for time, $[u]$ for thermodynamic temperature, and $[nd]$ for non-dimensional quantities. Use of these symbols is restricted to analytical dimensions when used with square brackets, as the symbols may have other definitions when used without the brackets.

3.2 Definitions of Terms Specific to This Standard:

3.2.1 *crack opening mode (Mode I)*—fracture mode in which the delamination faces open away from each other and no relative crack face sliding occurs.

3.2.2 *crack sliding mode (Mode II)*—fracture mode in which the delamination faces slide over each other in the direction of delamination growth and no relative crack face opening occurs.

3.2.3 *mixed-mode fracture toughness, $G_c [M/T^2]$* —the critical value of strain energy release rate, G , for delamination growth in mixed-mode.

3.2.4 *mixed-mode ratio, $G_I/G_{II} [nd]$* —the ratio of Mode I strain energy release rate to Mode II strain energy release rate.

3.2.5 *mode mixture, $G_{II}/G [nd]$* —fraction of Mode II to total strain energy release rate. The mixed-mode ratio, G_I/G_{II} , is at times referred to instead of the mode mixture.

3.2.6 *Mode I strain energy release rate, $G_I [M/T^2]$* —the loss of strain energy associated with Mode I deformation in the test specimen per unit of specimen width for an infinitesimal increase in delamination length, da , for a delamination growing under a constant displacement.

3.2.7 *Mode II strain energy release rate, $G_{II} [M/T^2]$* —the loss of strain energy associated with Mode II deformation in the test specimen per unit of specimen width for an infinitesimal increase in delamination length, da , for a delamination growing under a constant displacement.

3.2.8 *strain energy release rate, $G [M/T^2]$* —the loss of strain energy, dU , in the test specimen per unit of specimen width for an infinitesimal increase in delamination length, da , for a delamination growing under a constant displacement. In mathematical form,

$$G = -\frac{1}{b} \frac{dU}{da} \quad (1)$$

where:

- a = delamination length, mm [in.],
- b = width of specimen, mm [in.],
- G = total strain energy release rate, kJ/m^2 [in.-lbf/in.²], and
- U = total elastic strain energy in the test specimen, N-mm [in.-lbf].

3.3 Symbols:

- a = delamination length, mm [in.]
- a_0 = initial delamination length, mm [in.]
- a_{1-25} = propagation delamination lengths, mm [in.]
- b = width of specimen, mm [in.]
- b_{cal} = width of calibration specimen, mm [in.]
- c = lever length of the MMB test apparatus, mm [in.]
- c_g = lever length to center of gravity, mm [in.]
- C = compliance, δ/P , mm/N [in./lbf]
- C_{cal} = calibration specimen compliance, δ/P , mm/N [in./lbf]
- C_{sys} = system compliance, δ/P , mm/N [in./lbf]
- CV = coefficient of variation, %
- E_{11} = longitudinal modulus of elasticity measured in tension, MPa [psi]
- E_{22} = transverse modulus of elasticity, MPa [psi]
- E_{cal} = modulus of calibration bar, MPa [psi]
- E_{1f} = modulus of elasticity in the fiber direction measured in flexure, MPa [psi]
- G = total strain energy release rate, kJ/m^2 [in.-lbf/in.²]

- G_{13} = shear modulus out of plane, MPa [psi]
- G_{12} = shear modulus in plane, MPa [psi]
- G_I = opening (Mode I) component of strain energy release rate, kJ/m^2 [in.-lbf/in²]
- G_{II} = shear (Mode II) component of strain energy release rate, kJ/m^2 [in.-lbf/in²]
- G_{II}/G = mode mixture
- G_c = total mixed-mode fracture toughness, kJ/m^2 [in.-lbf/in²]
- G_c^{est} = estimated value of total mixed-mode fracture toughness, kJ/m^2 [in.-lbf/in²]
- h = half thickness of test specimen, mm [in.]
- L = half-span length of the MMB test apparatus, mm [in.]
- m = slope of the load displacement curve, N/mm [lb/in.]
- m_{cal} = slope of the load displacement curve from calibration test, N/mm [lb/in.]
- P = applied load, N [lbf]
- $P_{5\%/\text{max}}$ = critical load at 5 %/max point of loading curve, N [lbf]
- P_{est} = estimated value of critical load, N [lbf]
- P_g = weight of lever and attach apparatus, N [lbf]
- P_{nl} = critical load at nonlinear point of loading curve, N [lbf]
- P_{tab} = expected load on the loading tab, N [lbf]
- P_{vis} = critical load when delamination is observed to grow, N [lbf]
- SD = standard deviation
- t = thickness of calibration bar, mm [in.]
- U = strain energy, N-mm [in.-lbf]
- V = fiber volume fraction, %
- α = mode mixture transformation parameter for setting lever length
- β = non-dimensional crack length correction for mode mixture
- χ = crack length correction parameter,

iTeh Standards
(<https://standards.itih.ai>)

$$\chi = \sqrt{\frac{E_{11}}{11G_{13}} \left\{ 3 - 2 \left(\frac{\Gamma}{1+\Gamma} \right)^2 \right\}}$$

- δ = load point deflection, mm [in.]
- δ^{est} = estimated load point deflection, mm [in.]
- δ^{max} = maximum allowable load point of deflection, mm [in.]
- Γ = transverse modulus correction parameter,

ASTM D6671/D6671M-13e1

<https://standards.itih.ai/catalog/standards/sist/129776e8-3330-406f-9f18-16c29e0f2628/astm-d6671-d6671m-13e1>

$$\Gamma = 1.18 \frac{\sqrt{E_{11}E_{22}}}{G_{13}}$$

4. Summary of Test Method

4.1 The Mixed-Mode Bending (MMB) test apparatus shown in Fig. 1 is used to load split laminate specimens to determine the delamination fracture toughness at various ratios of Mode I to Mode II loading. The composite test specimen, shown in Fig. 2, consists of a rectangular, uniform thickness, unidirectional laminated composite specimen, containing a nonadhesive insert at the midplane which serves as a delamination initiator. Loading forces are applied to the MMB specimen via tabs that are applied near the ends of the delaminated section of the specimen and through rollers that bear against the specimen in the nondelaminated region. The base of the MMB apparatus holds the specimen stationary while the MMB lever loads the specimen. The base attaches to the bottom specimen tab and also bears on the specimen near the far end with a roller. The lever attaches to the top tab and bears

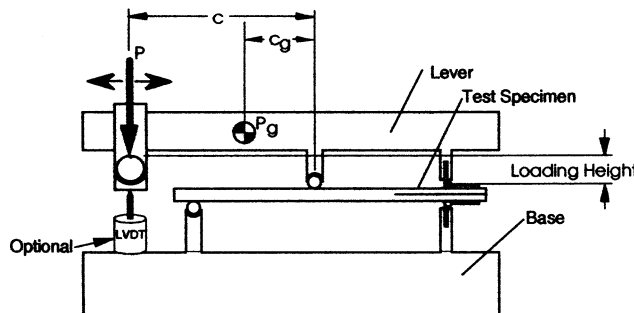

FIG. 1 MMB Apparatus

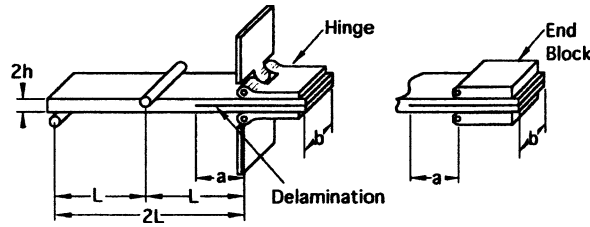

FIG. 2 MMB Test Variables

down on the specimen halfway between the base roller and the tabs. The lever roller acts as a fulcrum so by pushing down on the lever arm opposite the tab, the tab is pulled up. The length of the lever arm, c , can be changed to vary the ratio of the load pulling on the tab to the load bearing through the roller thus changing the mode mixture of the test. The load shall be applied to the lever such that the load remains vertical during the loading process. To reduce geometric nonlinear effects as a result of lever rotation, the lever shall be loaded such that the height of loading is slightly above the pivot point where the lever attaches to the test specimen (1, 2).³

4.2 A record of the applied load versus opening displacement is recorded on an x - y recorder, or equivalent real-time plotting device or stored digitally and post-processed. The interlaminar fracture toughness, G_c , and mode mixture, G_{II}/G , are calculated from critical loads read from the load displacement curve.

5. Significance and Use

5.1 Susceptibility to delamination is one of the major weaknesses of many advanced laminated composite structures. Knowledge of the interlaminar fracture resistance of composites is useful for product development and material selection. Since delaminations can be subjected to and extended by loadings with a wide range of mode mixtures, it is important that the composite toughness be measured at various mode mixtures. The toughness contour, in which fracture toughness is plotted as a function of mode mixtures (see Fig. 3), is useful for establishing failure criterion used in damage tolerance analyses of composite structures made from these materials.

5.2 This test method can serve the following purposes:

5.2.1 To establish quantitatively the effects of fiber surface treatment, local variations in fiber volume fraction, and processing and environmental variables on G_c of a particular composite material at various mode mixtures,

5.2.2 To compare quantitatively the relative values of G_c versus mode mixture for composite materials with different constituents, and

5.2.3 To develop delamination failure criteria for composite damage tolerance and durability analyses.

5.3 This method can be used to determine the following delamination toughness values:

5.3.1 *Delamination Initiation*—Two values of delamination initiation shall be reported: (1) at the point of deviation from linearity in the load-displacement curve (NL) and (2) at the point at which the compliance has increased by 5 % or the load has reached a maximum value (5 %/max) depending on which occurs first along the load deflection curve (see Fig. 4). Each definition of delamination initiation is associated with its own value of G_c and G_{II}/G calculated from the load at the corresponding critical point. The 5 %/Max G_c value is typically the most reproducible of the three G_c values. The NL value is, however, the more conservative number. When the option of collecting propagation values is taken (see 5.3.2), a third initiation value may be reported at the point at which the delamination is first visually observed to grow on the edge of the specimen. The VIS point often falls between the NL and the 5 %/Max points.

³ The boldface numbers in parentheses refer to a list of references at the end of this standard.

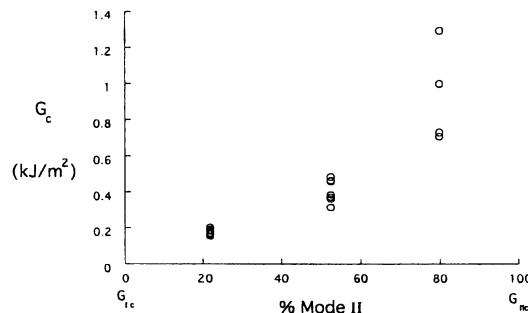

FIG. 3 Mixed-Mode Summary Graph

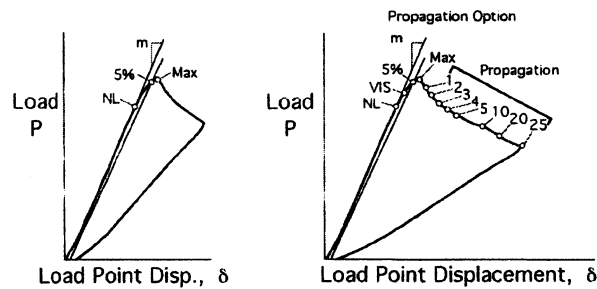

FIG. 4 Load-Displacement Curves

5.3.2 *Propagation Option*—In the MMB test, the delamination will grow from the insert in either a stable or an unstable manner depending on the mode mixture being tested. As an option, propagation toughness values may be collected when delaminations grow in a stable manner. Propagation toughness values are not attainable when the delamination grows in an unstable manner. Propagation toughness values may be heavily influenced by fiber bridging which is an artifact of the zero-degree-type test specimen (3-5). Since they are often believed to be artificial, propagation values must be clearly marked as such when they are reported. One use of propagation values is to check for problems with the delamination insert. Normally, delamination toughness values rise from the initiation values as the delamination propagates and fiber bridging develops. When toughness values decrease as the delamination grows, a poor delamination insert is often the cause. The delamination may be too thick or deformed in such a way that a resin pocket forms at the end of the insert. For accurate initiation values, a properly implanted and inspected delamination insert is critical (see 8.2).

5.3.3 *Precracked Toughness*—Under rare circumstances, toughness may decrease from the initiation values as the delamination propagates (see 5.3.2). If this occurs, the delamination should be checked to insure that it complies with the insert recommendations found in 8.2. Only after verifying that the decreasing toughness was not due to a poor insert, should precracking be considered as an option. With precracking, a delamination is first extended from the insert in Mode I, Mode II, or mixed mode. The specimen is then reloaded at the desired mode mixture to obtain a toughness value.

6. Interferences

6.1 Linear elastic behavior is assumed in the calculation of G_c used in this test method. This assumption is valid when the zone of damage or nonlinear deformation at the delamination front, or both, is small relative to the smallest specimen dimension, which is typically the specimen thickness for the MMB test.

6.2 The application to other materials, layups, and architectures is the same as described in Test Method D5528.

6.3 The nonlinear (NL) initiation value of toughness is normally the more conservative value, but a few materials have exhibited lower propagation toughness values, particularly in the high Mode II regime. In the high Mode II regime, the delamination growth is often unstable, precluding propagation toughness values from being determined. The use of initiation toughness values could result in nonconservative growth predictions in these select materials. The use of longer initial delaminations increases the tendency for stable delamination growth.

7. Apparatus

7.1 The mixed-mode bending fixture, as seen in Fig. 5, uses a lever to load the MMB specimen. Using one applied load at the end of the lever, a downward load is applied to the specimen center creating Mode II, while an upward force is applied to the split end of the laminate creating Mode I. Machine drawings for an example of MMB apparatus may be found in Appendix X2, but other designs that perform the necessary functions are acceptable. The half-span length of the MMB Apparatus L (see Fig. 2) shall be 50 mm [2 in.]. To keep geometric nonlinear effects small, the loading height (the height of the loading point above the hinge point attaching the lever to the test specimen, as shown in Fig. 1) shall be $0.3 L$ and the applied load shall remain vertical as the apparatus is loaded. The load application to the lever and to the test specimen should allow sliding with minimal friction. In the pictured apparatus, this is accomplished with roller bearings, but equivalent means are acceptable.

7.2 *Testing Machine*—A properly calibrated test machine shall be used which can be operated in a displacement control mode with a constant displacement rate in the range of 0.5 to 5.0 mm/min [0.02 to 0.20 in./min]. The testing machine shall conform to the requirements of Practices E4. The testing machine shall be equipped with a clevis which can be attached to the loading yoke of the MMB apparatus and an anvil on which the base of the MMB apparatus can be placed.

7.3 *Load Indicator*—The testing machine load-sensing device shall be capable of indicating the total load carried by the test specimen. This device shall be essentially free from inertia lag at the specified rate of testing and shall indicate the load with an accuracy over the load range(s) of interest of within $\pm 1\%$ of the indicated value.

7.4 *Load Point Displacement Indicator*—The load point displacement may be taken from the crosshead separation of the load frame or from an external gage attached to the MMB apparatus. If the crosshead separation is used as the measurement of load

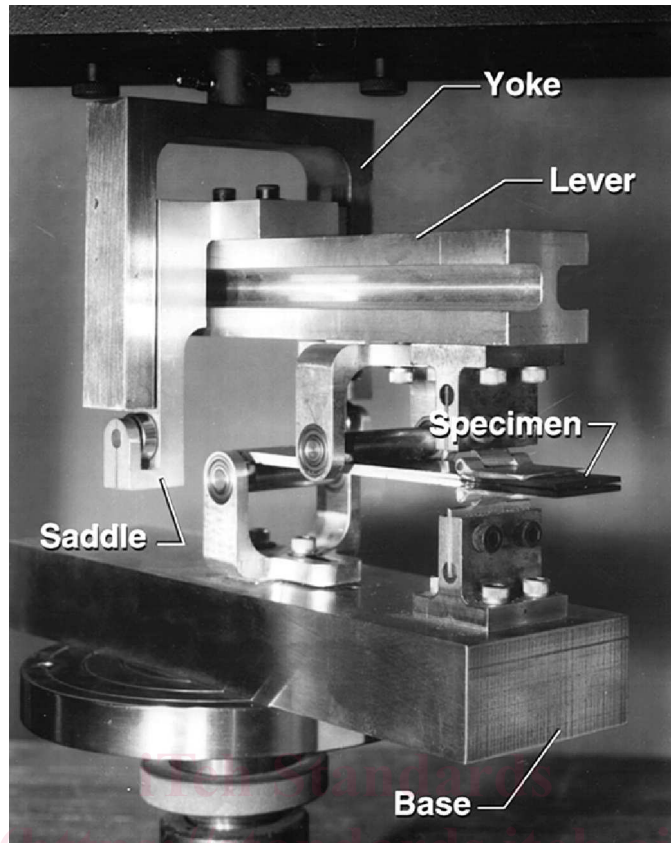

FIG. 5 Mixed-Mode Bending Fixture

Document Preview

point displacement, correction must be made for the compliance of the loading system, C_{sys} which includes the compliance of the load frame and the MMB apparatus. The compliance of the loading system must be measured at each lever length c to be used during testing (see 11.5). The C_{sys} will be used in the equation for specimen modulus to correct for the load system compliance.

7.4.1 The load point displacement may be obtained from a properly calibrated external gage or transducer attached to the MMB apparatus such as the linearly variable displacement transducer (LVDT) shown in Fig. 1. The displacement indicator shall indicate the load point displacement with an accuracy of within $\pm 1\%$ of the indicated value once the delamination occurs. If the load point displacement is taken from an external gage or transducer, the C_{sys} value should be set to zero in the specimen modulus equation (Eq 10).

7.5 *Load Versus Load Point Displacement Record*—An x - y plotter, or similar device, shall be used to make a permanent record during the test of load versus opening displacement at the point of load application. Alternatively, the data may be stored digitally and postprocessed.

7.6 *Optical Microscope (Only for Propagation Option)*—A traveling optical microscope with a magnification no greater than 70 \times , or an equivalent magnifying device, shall be positioned on one side of the specimen to observe the delamination front as it extends along one edge during the test visually. This device shall be capable of pinpointing the delamination front with an accuracy of at least ± 0.5 mm [± 0.02 in.]. A mirror may be used to determine any discrepancy visually in delamination onset from one side of the specimen to the other. Other methods, such as crack length gages bonded to a specimen edge, may be used to monitor delamination length provided their accuracy is as good as the optical microscope so that delamination length may be measured to the accuracy specified above.

7.7 The micrometer(s) shall use a suitable size diameter ball-interface on irregular surfaces such as the bag side of a laminate and a flat anvil interface on machined edges or very smooth tooled surfaces. The accuracy of the instruments shall be suitable for reading to within 1% of the sample width and thickness. For typical specimen geometries, an instrument with an accuracy of ± 0.025 mm [0.001 in.] is desirable for thickness and width measurements.

8. Sampling and Test Specimens

8.1 Test laminates must contain an even number of plies, and shall be unidirectional, with delamination growth occurring in the 0° direction.