



# Standard Test Method for Cyclic Pressure Strength of Reinforced, Thermosetting Plastic Pipe<sup>1</sup>

This standard is issued under the fixed designation D2143; the number immediately following the designation indicates the year of original adoption or, in the case of revision, the year of last revision. A number in parentheses indicates the year of last reapproval. A superscript epsilon ( $\epsilon$ ) indicates an editorial change since the last revision or reapproval.

## 1. Scope—Scope\*

1.1 This test method covers the determination of the failure characteristics of reinforced plastic pipe when subjected to cyclic internal hydraulic pressure. It is limited to pipe in which the ratio of outside diameter to wall thickness is 10:1 or more.

1.2 The values stated in inch-pound units are to be regarded as the standard. The values in parentheses are for information only.

1.3 *This standard does not purport to address all of the safety concerns, if any, associated with its use. It is the responsibility of the user of this standard to establish appropriate safety and health practices and determine the applicability of regulatory limitations prior to use.*

NOTE 1—There is no similar or equivalent ISO known ISO equivalent to this standard.

## 2. Referenced Documents

2.1 *ASTM Standards:*<sup>2</sup>

D618 Practice for Conditioning Plastics for Testing

D2992 Practice for Obtaining Hydrostatic or Pressure Design Basis for “Fiberglass” (Glass-Fiber-Reinforced Thermosetting-Resin) Pipe and Fittings

D3567 Practice for Determining Dimensions of “Fiberglass” (Glass-Fiber-Reinforced Thermosetting Resin) Pipe and Fittings

## 3. Terminology

3.1 *Definitions of Terms Specific to This Standard:*

3.1.1 *failure*—the transmission of the test fluid through the pipe wall in any manner, whether it be wall fracture, localized leaking, or weeping at a distance greater than one diameter from the end closure (specimens failing within one diameter of the end closure shall be discarded).

3.1.2 *failure detector*—a device that measures the electrical resistance between the test fluid and a conductive material, wrapped around the circumference of the test specimen, and which will indicate failure when 1) the resistance is lowered to a range from 10 to 20 meg-ohm or 2) for the case of municipal water, when the first drop of fluid has passed through the wall of the specimen.

3.1.3 *localized leaking*—failure that occurs as small fractures (one or more in a test specimen) that permit the test fluid to be transferred at a rate that is measured by the failure detector.

3.1.4 *weeping*—a general transmission of the test fluid through the pipe, without visible fracture, at a sufficient rate to be measured by the failure detector, or in the case of larger magnitudes of fluid transmission appear to be moisture condensation on the specimen.

3.1.5 *wall fracture*—failure by a break in the pipe wall causing immediate loss of test fluid and continued loss at essentially no pressure.

## 4. Summary of Test Method

4.1 This test method consists of exposing pipe specimens to cyclic internal pressures at several different pressure levels and measuring the cycles to failure at these different levels. Test temperatures are obtained by circulating salt water or municipal water through the specimens.

<sup>1</sup> This test method is under the jurisdiction of ASTM Committee D20 on Plastics and is the direct responsibility of Subcommittee D20.23 on Reinforced Plastic Piping Systems and Chemical Equipment.

Current edition approved Nov. 1, 2010; May 1, 2015. Published March 2011; June 2015. Originally approved in 1963. Last previous edition approved in 2005 (2010) as D2143 – 00 (2005) (2010). DOI: 10.1520/D2143-00R10; 10.1520/D2143-15.

<sup>2</sup> For referenced ASTM standards, visit the ASTM website, www.astm.org, or contact ASTM Customer Service at service@astm.org. For Annual Book of ASTM Standards volume information, refer to the standard’s Document Summary page on the ASTM website.

\*A Summary of Changes section appears at the end of this standard

**5. Significance and Use**

- 5.1 The values obtained by this test method are applicable only to conditions that specifically duplicate the procedures used.
- 5.2 After the regression characteristics of a pipe material and manufacturing process have been determined by this test method, one pressure may be used for quality-control purposes. This pressure shall be one of the points used in the original determination and be agreed upon between the individuals concerned.
- 5.3 This test method deals with cyclic internal pressure performance of a pipe and omits creep and nonrecoverable deformation measurements.
- 5.4 For determination of the cyclic hydrostatic design basis using data from this test method see Practice D2992.
- 5.5 In the application of the following test requirements and recommendations it is assumed that test specimens of a given sample of pipe are truly representative of that material and manufacturing process. In tests conducted to show the effect of temperature and pressures on the life span of the pipe, great care must be taken to ensure that the specimens being tested are representative of the group being studied. Departure from this assumption could introduce discrepancies that are greater than those introduced by departure from the details of the procedure outlined in this test method.

**6. Apparatus**

- 6.1 A schematic diagram of the apparatus is shown in Fig. 1 and shall consist of the following:
  - 6.1.1 *Pressurizing System*—A device capable of exerting cyclic internal pressure of the salt water or municipal water to the test specimens. Fig. 1 shows an oil pump leading to a four-way solenoid-operated valve which directs the fluid alternately to the two pressure legs, each of which contains a spring-operated, manually adjustable, pressure relief valve and an accumulator which acts as a fluid separator transferring the pressurizing medium to the salt solution or municipal water. The solenoid is operated with equal on and off times by an electric pulsator.
  - 6.1.2 *Test Fluid*—The test fluid shall be a 2 % aqueous sodium chloride solution when salt water or municipal water is used.
  - 6.1.3 *Temperature Bath*—A thermostatically controlled bath coupled into the test fluid, which maintains specimen temperature to within  $\pm 5^{\circ}\text{F}$  ( $\pm 2^{\circ}\text{C}$ ). The circulation of this fluid is pumped on the off portion of the pressure cycle.
  - 6.1.4 *Pressure Gages*—Pressure gages having a precision of not less than 1 % of full-scale deflection with a maximum indicating hand. The pressure gage shall be selected such that the final readings are in the mid-60 % range of the scale. The gage should be equipped with a surge protection device.

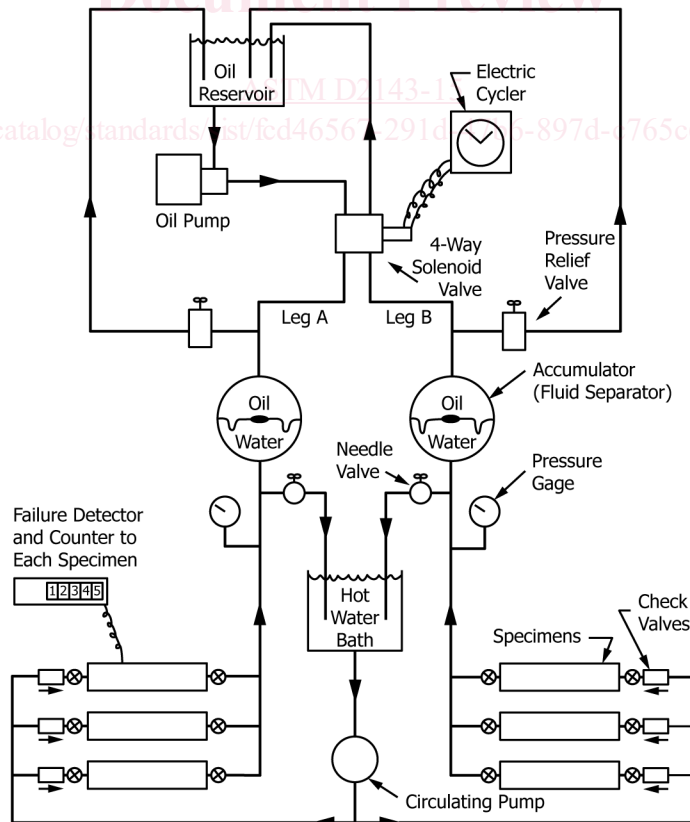

FIG. 1 Schematic Drawing of Cyclic Pressure Apparatus