



Designation: F1235 – 15

Standard Consumer Safety Specification for Portable Hook-On Chairs¹

This standard is issued under the fixed designation F1235; the number immediately following the designation indicates the year of original adoption or, in the case of revision, the year of last revision. A number in parentheses indicates the year of last reappraisal. A superscript epsilon (ϵ) indicates an editorial change since the last revision or reappraisal.

INTRODUCTION

This consumer safety specification addresses incidents associated with portable hook-on chairs (chairs) that were identified by the United States Consumer Product Safety Commission (CPSC).

CPSC has identified injuries which occurred when chairs fell because the child pushed off the table, components of the chair became detached or broke, and, to a lesser extent, when the table to which the chair was attached tipped over. In response to a review of the data received by the CPSC, this specification attempts to minimize the following: falls due to detachment of the chair from the table or due to breakage or detachment of components; a child falling out of the chair; and chair and table tipping over.

This specification does not cover chairs that are either blatantly misused or are used in a careless manner that disregards the warning statements and safety instructions provided with each chair. This specification is written within the current state-of-the-art of chair technology. It is intended that this specification will be updated whenever substantive information becomes available that necessitates additional requirements or justifies revising the existing requirements.

1. Scope

1.1 This specification covers the performance requirements and test methods designed to ensure the satisfactory performance of the portable hook-on chair.

1.2 This specification is intended to minimize injuries to children resulting from normal use and reasonably foreseeable misuse or abuse of chairs.

1.3 For the purposes of this specification a chair is:

1.3.1 A seat made for the express purpose of seating and holding a child who can remain in a sitting position due to his or her own coordination.

1.3.2 Usually a legless seat constructed to locate the occupant at a table in such a position and elevation so that the surface of the table can be used as the feeding surface for the occupant.

1.3.3 Supported solely by the table on which it is mounted. These chairs are intended for use by children between the ages of six months and three years and who weigh no more than 37 lb (16.8 kg) (95th percentile male at three years).

1.4 No chair produced after the approval date of this consumer safety specification shall, either by label or other

means, indicate compliance with this specification unless it conforms to all applicable requirements contained herein.

1.5 The values stated in inch-pound units are to be regarded as standard. The values given in parentheses are mathematical conversions to SI units that are provided for information only and are not considered standard.

1.6 The following precautionary caveat pertains to the test methods portion only, Section 7, of this specification: *This standard does not purport to address all of the safety concerns, if any, associated with its use. It is the responsibility of the user of this standard to establish appropriate safety and health practices and determine the applicability of regulatory limitations prior to use.*

2. Referenced Documents

2.1 *ASTM Standards*:²
D3359 Test Methods for Measuring Adhesion by Tape Test

2.2 *Federal Regulations*:
16 CFR 1303 Ban of Lead-Containing Paint, and Certain Consumer Products Bearing Lead-Containing Paint³

¹ This specification is under the jurisdiction of ASTM Committee F15 on Consumer Products and is the direct responsibility of Subcommittee F15.16 on Highchairs, Hook-On Chairs and Expandable Gates.

Current edition approved May 1, 2015. Published June 2015. Originally approved in 1989. Last previous edition approved in 2014 as F1235 – 14a. DOI: 10.1520/F1235-15.

² For referenced ASTM standards, visit the ASTM website, www.astm.org, or contact ASTM Customer Service at service@astm.org. For *Annual Book of ASTM Standards* volume information, refer to the standard's Document Summary page on the ASTM website.

³ Available from U.S. Government Printing Office, N. Capital and H Streets, NW, Washington, DC 20401.

16 CFR 1500 Hazardous Substances Act Regulations including sections:

1500.48 Technical Requirements for Determining a Sharp Point in Toys or Other Articles Intended for Use By Children Under Eight Years of Age³

1500.49 Technical Requirements for Determining a Sharp Metal or Glass Edge in Toys or Other Articles Intended for Use By Children Under Eight Years of Age³

1500.50.52 Test Methods for Simulating Use and Abuse of Toys and Other Articles Intended for Use by Children³

16 CFR 1501 Method for Identifying Toys and Other Articles Intended for Use by Children Under Three Years of Age Which Present Choking, Aspiration, or Ingestion Hazards Because of Small Parts³

3. Terminology

3.1 *Definitions of Terms Specific to This Standard:*

3.1.1 *conspicuous*—a label that is visible when the portable hook-on chair is in a manufacturer's recommended use position to a person standing near the chair at any one position but not necessarily visible from all positions.

3.1.2 *fabric*—any woven, knit, coated, laminated, extruded or calendered flexible material that is intended to be sewn, welded, heat sealed or glued together as an assembly.

3.1.3 *manufacturer's recommended use position*—any position that is presented as a normal, allowable, or acceptable configuration for the use of the product by the manufacturer in any descriptive or instructional literature. This specifically excludes positions that the manufacturer shows in a like manner in its literature to be unacceptable, unsafe, or not recommended.

3.1.4 *nonpaper label*—any label material (such as plastic or metal) which either will not tear without the aid of tools, or tears leaving a sharply defined edge.

3.1.5 *occupant*—that individual who is in a product that is set up in one of the manufacturer's recommended use positions.

3.1.6 *passive crotch restraint*—a component that separates the openings for the legs of the occupant into two separate bounded openings and requires no action on the part of the caregiver to use, except to position one leg into each opening created by the component.

3.1.7 *paper label*—any label material that tears without the aid of tools and leaves a fibrous edge.

3.1.8 *seam*—a means of joining fabric components such as sewing, welding, heat sealing or gluing.

3.1.9 *static load*—a vertically downward force applied by a calibrated force gage or by dead weights.

4. Calibration and Standardization

4.1 All testing shall be conducted on a concrete floor that may be covered with 1/8 in. (3 mm) thick vinyl flooring covering, unless test instructs differently.

4.2 The product shall be completely assembled, unless otherwise noted, in accordance with the manufacturer's instructions.

4.3 No testing shall be conducted within 48 h of manufacturing.

4.4 The product to be tested shall be in a room with ambient temperature of 73 ± 9°F (23 ± 5°C) for at least 1 h prior to testing. Testing shall then be conducted within this temperature range.

4.5 All testing required by this specification shall be conducted on the same unit.

5. General Requirements

5.1 There shall be no hazardous sharp points or edges as defined by 16 CFR 1500.48 and 16 CFR 1500.49 before and after testing to this consumer safety specification.

5.2 There shall be no small parts as defined by 16 CFR 1501 before testing or liberated as a result of testing to this specification.

5.3 The paint and surface-coatings on the product shall comply with 16 CFR 1303.

5.4 Prior to testing, any exposed wood parts shall be smooth and free from splinters.

5.5 *Latching or Locking Mechanisms*—Any unit that folds shall have a latching or locking device or other provision in the design that will prevent the unit from unintentionally folding when properly placed in the manufacturer's recommended use position. The unit shall remain in its manufacturer's recommended use position during and upon completion of the test in accordance with 7.3. If a unit is designed with a latching or locking device, that device shall remain engaged and operative after testing.

5.6 *Scissoring, Shearing, and Pinching:*

5.6.1 A portable hook-on chair, when in a manufacturer's recommended use position installed per the manufacturer's instructions on the minimum test surface described in 7.1.16.4, shall be designed and constructed so as to prevent injury to the occupant from any scissoring, shearing, or pinching when members or components rotate about a common axis or fastening point, slide, pivot, fold, or otherwise move relative to one another. Scissoring, shearing, or pinching that may cause injury shall not be permissible when the edges of any rigid parts admit a probe greater than 0.210 in. (5.33 mm) and less than 0.375 in. (9.53 mm) diameter at any accessible point throughout the range of motion of such parts.

5.6.2 *Disengagement from Table Support Surface*—Scissoring, shearing, or pinching that may cause injury shall not be permissible when an opening in the spaces described below admits a probe greater than 0.210 in. (5.33 mm) and less than 0.375 in. (9.53 mm) in diameter at any accessible point throughout the range of motion that occurs during the test outlined in 7.13.

(1) between the edges of any rigid part of the product and the test surface, or

(2) between the edges of any two rigid parts on the product that rotate about a common axis or fastening point.

5.7 *Exposed Coil Springs*—Any exposed coil spring that is accessible to the occupant, having or capable of generating a space between coils of 0.210 in. (5.30 mm) or greater during

static load testing in accordance with 7.6, shall be covered or otherwise designed to prevent injury from entrapment.

5.8 *Openings*—Holes or slots that extend entirely through a wall section of any rigid material less than 0.375-in. (9.53-mm) thick and admit a 0.210-in. (5.33-mm) diameter rod shall also admit a 0.375-in. (9.53-mm) diameter rod. Holes or slots that are between 0.210-in. (5.33-mm) and 0.375-in. (9.53-mm) and have a wall thickness less than 0.375-in. (9.53-mm) but are limited in depth to 0.375-in. (9.53-mm) maximum by another rigid surface shall be permissible (see Fig. 1). The product shall be evaluated in all manufacturer’s recommended use positions.

5.9 *Labeling:*

5.9.1 Warning labels (whether paper or non paper) shall be permanent when tested in accordance with 7.11.

5.9.2 Warning statements applied directly onto the surface of the product by hot stamping, heat transfer, printing, wood burning, and so forth shall be permanent when tested in accordance with 7.11.

5.9.3 Nonpaper labels shall not liberate small parts when tested in accordance with 7.11.

5.10 *Protective Components*—If a child can grasp components between the thumb and forefinger, or teeth, (such as caps, sleeves, or plugs used for protection from sharp edges, points, or entrapment of fingers or toes), or if there is at least a 0.040 in. (1.00 mm) gap between the component and its adjacent parent component, such component shall not be removed when tested in accordance with 7.4.

6. Performance Requirements

6.1 *Chair Drop Test*—The chair shall permit subsequent tests and exhibit no mechanical hazards (sharp points, sharp edges, or small parts) when tested in accordance with 7.5.

6.2 *Static Load Test*—The chair shall support a static load on the seat without causing any hazardous conditions as identified within this specification when tested in accordance with 7.6.

6.3 *Seat and Seat Back Disengagement Test*—The seat back and seat shall remain fully attached to the frame of the chair when forces are applied in accordance with 7.7.

6.4 *Chair Bounce Test*—The chair shall remain attached to the standard test surface as described in 7.1.16 and allow no movement greater than 1 in. (25 mm) when forces are applied in accordance with 7.8.

6.5 *Chair Pull/Push Test*—The chair shall remain attached to the standard test surface when tested in accordance with 7.9.

6.6 *Restraint Systems:*

6.6.1 A restraint system shall be provided to secure a child in the seated position in each of the manufacturer’s recommended use positions.

6.6.1.1 The restraint system shall include both waist and crotch restraint. The crotch restraint shall be designed such that its use is mandatory when the restraint system is in use.

NOTE 1—It should be noted that this test applies to all designs of restraining systems, whether they be of the traditional “active” or of the “passive” type.

6.6.2 The restraint system and its closing means (for example, buckle) shall not break, separate or permit removal of the CAMI test dummy (see Fig. 2) from the chair when tested in accordance with 7.10.

6.6.2.1 If during the tests in 7.10 the posterior of the test dummy, with the force applied, is pulled past the front edge of the seat, the dummy shall be considered removed.

6.6.2.2 After the tests in 7.10.6 and 7.10.7, the CAMI dummy shall not be fully released.

6.6.3 The waist restraint shall be capable of adjustment with a positive self-locking mechanism that is capable, when locked, of withstanding the forces of tests in 7.10 without allowing restraint movement or slippage of more than 1 in. (25 mm).

6.6.4 A connecting means and adjustment means for the waist restraint shall be capable of usage independent of one another. The connecting means shall not be an adjustment means, but may have one integrally attached to it.

6.6.5 Before shipment, the restraining system must be attached to the chair in such a manner as to not become detached through normal use. For chairs requiring consumer assembly, buckles must be completely threaded and the restraining system must be attached to a component that would render the chair unusable if not properly assembled.

6.7 *Openings and Passive Crotch Restraint System:*

NOTE 2—A passive crotch restraint required by this section does not meet the restraint system requirement of 6.6.1.1, which requires a crotch restraint as part of the restraint system.

6.7.1 The hook-on chair shall have a passive crotch restraint that meets the following:

6.7.1.1 The passive crotch restraint shall be installed on the product at the time of shipment.

6.7.1.2 The leg openings on each side of the passive crotch restraint shall not allow complete passage of the wedge block when tested in accordance with 7.12.

6.7.2 Completely bounded openings in the surfaces that act as the sides of the seating area shall not allow complete passage of the wedge block when tested in accordance with 7.12.

6.7.3 Completely bounded openings that are located forward of the occupant shall not allow complete passage of the wedge block when tested in accordance with 7.12 (see Fig. 3).

6.7.3.1 Openings in the attachment structure of the product located under the standard test surface are exempt from this requirement (see Fig. 4).

7. Test Methods

7.1 *Test Equipment:*

7.1.1 A push-pull gage.

7.1.2 A CAMI Infant Dummy Mark II (see Fig. 2).⁴

7.1.3 Tension test adapter/clamp (see Fig. 5).

7.1.4 A 0.040 in. (1.00 mm) feeler gage.

7.1.5 A wood block 6 by 6 by ¾ in. thick (150 by 150 by 19 mm). In all cases where there is a hammock type seat, use the weld cap as described in 7.1.6.

⁴ CAMI Infant Dummy (Mark II), Department of Transportation, Federal Aviation Administration, Cami Infant Dummy, Drawing No. SA-100I, Memorandum Report AAC-119-74-14, Revision II, by Richard F. Chandler, July 2, 1974.

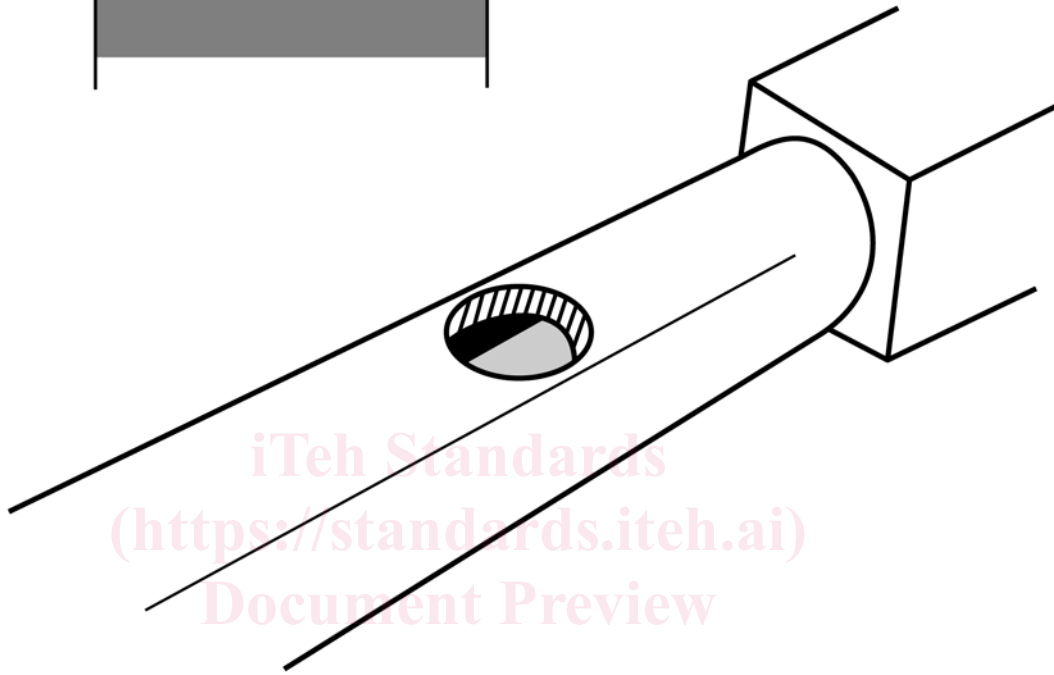
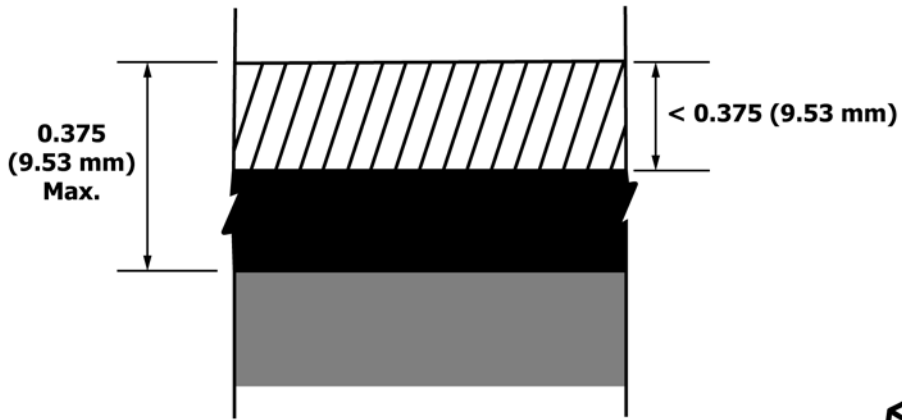

[ASTM F1235-15](https://standards.itih.ai/catalog/standards/sist/9e9e9367-af41-43a8-abc2-3e7230f64d3d/astm-f1235-15)

<https://standards.itih.ai/catalog/standards/sist/9e9e9367-af41-43a8-abc2-3e7230f64d3d/astm-f1235-15>

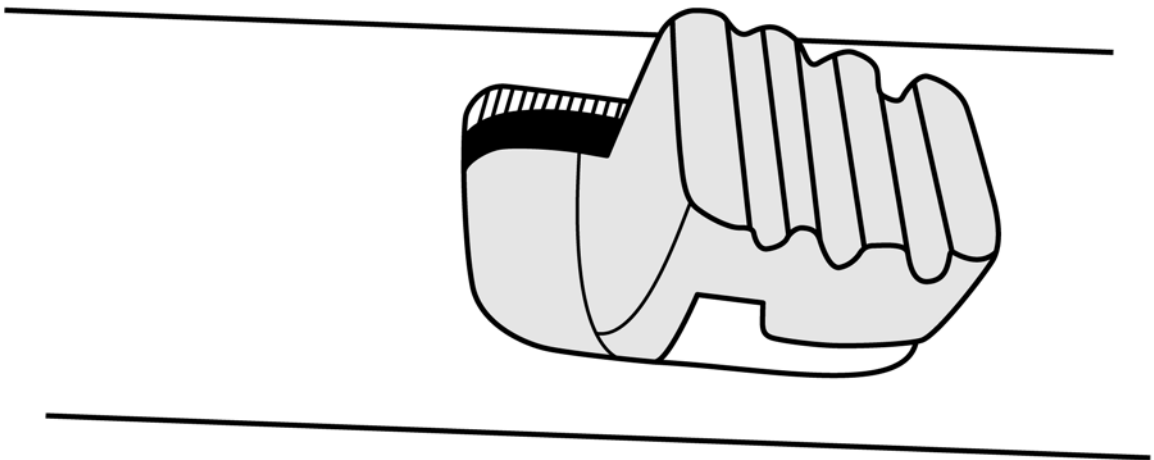

FIG. 1 Opening Example

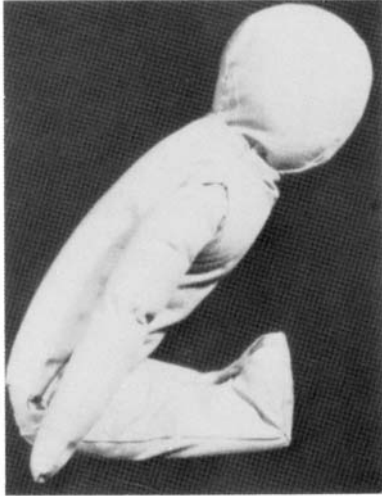

FIG. 2 CAMI Infant Dummy, Mark II⁶

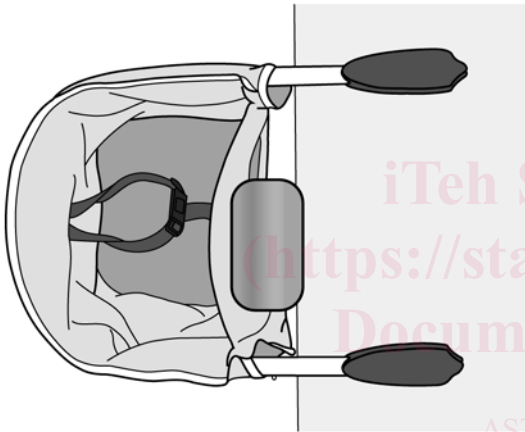

FIG. 3 Hook-On Chair Openings Evaluation

7.1.6 A 6 in. (150 mm) weld cap, as identified in Fig. 6, for use with a hammock type seat.

NOTE 3—If using a weld cap, subtract the weight of the cap from the indicated test weight.

7.1.7 A wood block 2 by 2 by 3/4 in. thick, (50 by 50 by 19 mm).

7.1.8 A 100 lb (45.5 kg) weight.

7.1.9 A 30 lb (13.6 kg) weight.

7.1.10 A 20 lb (9.1 kg) weight.

7.1.11 A 12 lb (5.4 kg) weight.

7.1.12 A 10 lb (4.5 kg) weight.

7.1.13 A 5 lb (2.2 kg) weight.

7.1.14 Webbing tension pull device (see Fig. 7).

7.1.15 A clamp with 3/4 in. (19 mm) diameter clamping surfaces.

7.1.16 *Standard Test Surface, Underlayment, and Thickness:*

7.1.16.1 The standard test surface should be a smooth finish, impregnated high pressure, high gloss laminate.⁵

7.1.16.2 The underlayment should be clean particle board, smooth side down.

7.1.16.3 Two standard test surface thicknesses are required.

7.1.16.4 The minimum test surface shall be equal to or to the nearest 1/4 in. (6 mm) greater than the minimum surface thickness stated by the manufacturer on the retail package.

7.1.16.5 The maximum test surface shall be equal to or to the nearest 1/4 in. (6 mm) less than the maximum thickness stated by the manufacturer on the retail package.

7.2 *Chair Assembly*—Assemble the chair in accordance with the manufacturer’s instructions.

7.3 *Latching Mechanisms for Prevention of Unintentional Folding:*

7.3.1 Securely affix the chair according to the manufacturer’s directions to the maximum test surface so that the normal folding motion is not impeded.

7.3.2 Gradually apply a force of 45 lbf (200 N) within 5 s and maintain for an additional 10 s. Apply the force in the direction normally associated with folding or disassembly of the chair at a position most likely to cause failure. Repeat twice for a total of three times within a 2 min period.

7.4 *Removal of Protective Components From Chairs:*

7.4.1 Any protective component which a child may reasonably be expected to grasp between the thumb and forefinger, or teeth, or that has at least a 0.040 in. (1.00 mm) gap between itself and its adjacent parent component shall be tested in accordance with each of the following methods in the sequence listed.

7.4.2 Secure the chair so that it cannot move during the performance of the following tests.

7.4.3 *Torque Test*—A torque of 3 lbf-in. (0.3 N·m) shall be applied evenly within a period of 5 s in a clockwise direction until a rotation of 180° from the original position has been attained or 3 lbf-in. (0.3 N·m) has been exceeded. The torque or 180° displacement shall be maintained for an additional 10 s. The torque shall then be removed and the test components permitted to return to a relaxed condition. This procedure shall then be repeated in a counterclockwise direction.

7.4.4 *Tension Test:*

7.4.4.1 Attach a force gage to the protective component by means of any suitable device. For components that cannot reasonably be expected to be grasped between thumb and forefinger, or teeth, on their outer diameter, but have at least a 0.040 in. (1.00 mm) gap or more behind the rear surface of the components and the structural member of the chair to which they are attached, a clamp such as shown in Fig. 5 may be a suitable device.

7.4.4.2 Be sure that the attachment device does not compress or expand the component so that it hinders any possible removal of the component.

7.4.4.3 Gradually apply a 15 lbf (67 N) force in a direction that would normally be associated with the removal of the

⁵ Formica, a registered trademark of Formica Corp., has been found suitable for this purpose.

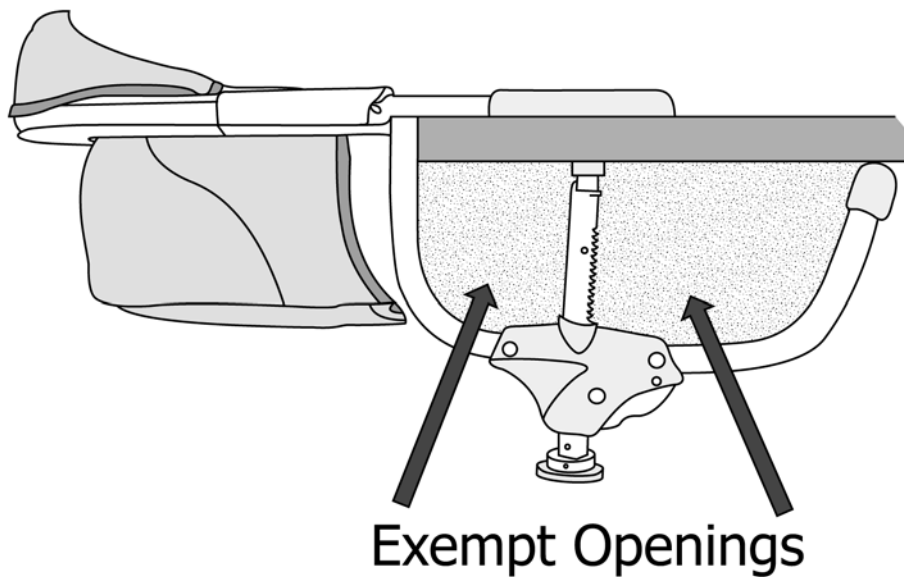
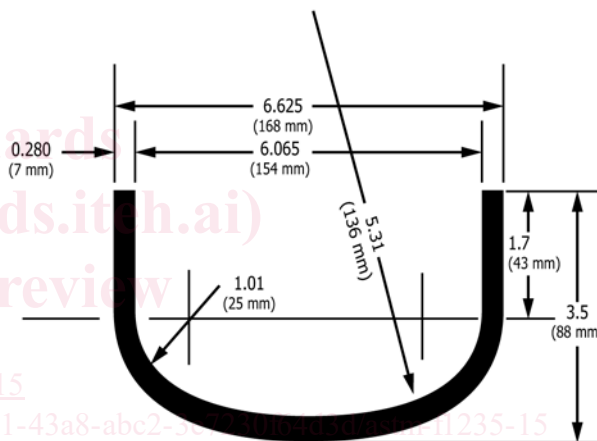

FIG. 4 Example of Exempt Openings Area

15 lbf (67 N) MAX TENSION



FIG. 5 Tension Test Adapter/Clamp



NOTE 1—Caps furnished to ANSI standards unless otherwise specified. Welding caps are formed from steel plate and are ellipsoidal in shape. The minor axis being equal to one half the major axis radii “R” and “r” closely approximate the actual semi-ellipsoidal shape. All dimensions in inches and are in accordance with ANSI B16.9.

FIG. 6 Nominal Weld 6 in. Weld Cap—Weight (Approximately) 6.4 lb

protective component. Gradually apply the force within 5 s and maintain for an additional 10 s.

7.5 Chair Drop Test:

7.5.1 Conduct all drop testing on a concrete floor, with 1/8 in. (3 mm) thick vinyl flooring cover.

7.5.2 Drop a chair that does not fold, from a height of 36 in. (910 mm). Drop the chair twice on each of six different planes.

7.5.3 Drop a chair that does fold, from a height of 36 in. (910 mm). Drop the chair once on each of six different planes, both in the folded and erect configurations.

7.5.4 Conduct all further tests on chairs that have passed this drop test.

7.6 Static Load Test:

7.6.1 Securely affix the chair according to manufacturers directions to the minimum standard test surface.

7.6.2 Place a weight of 100 lb (45.5 kg) on the center of the seat and distribute it upon the 6 by 6 in. wood block.

7.6.3 Maintain this load for 60 s.

7.6.4 Repeat this procedure on the maximum standard test surface.

7.7 Seat and Seat Back Disengagement Test:

7.7.1 All forces in this section shall be gradually applied over 5 s through the 2 by 2 in. wood block and maintained for an additional 10 s.

7.7.2 Step 1:

7.7.2.1 Securely affix the chair according to the manufacturer’s directions to the maximum test surface.