



Designation: **D4895 – 10 D4895 – 15**

Standard Specification for Polytetrafluoroethylene (PTFE) Resin Produced From Dispersion¹

This standard is issued under the fixed designation D4895; the number immediately following the designation indicates the year of original adoption or, in the case of revision, the year of last revision. A number in parentheses indicates the year of last reapproval. A superscript epsilon (ϵ) indicates an editorial change since the last revision or reapproval.

This standard has been approved for use by agencies of the U.S. Department of Defense.

1. Scope*

1.1 This specification² covers ~~dry powder resins of polytetrafluoroethylene (PTFE) that have been prepared from dispersions of PTFE by manufacturing techniques that involve controlled~~ prepared by coagulation of the dispersion. These resins are generally known as “fine powder” resins or “coagulated dispersion powder” resins. The conversion of these resins to finished products normally involves a process called “paste extrusion,” and sometimes involves formative processes such as calendaring. A volatile liquid is present as a processing aid during these formative stages of conversion, and is subsequently removed during the finishing stages of conversion. These PTFE resins are homopolymers of tetrafluoroethylene, or, in some cases, tetrafluoroethylene or modified homopolymers containing not more than 1 % by weight of other fluoromonomers. The usual methods of processing thermoplastics generally are not applicable to these materials because of their viscoelastic properties. The materials ~~materials~~ covered herein do not include mixtures of PTFE with additives such as colors, fillers, or plasticizers; nor do they include reprocessed or reground resin or any fabricated articles because the properties of such materials have been irreversibly changed when they were fibrillated or sintered. ~~The methods and properties included are those required to identify the various resins. An additional procedure is provided in the appendix for further characterization of the resins.~~

1.2 The values stated in SI units as detailed in **IEEE/ASTM SI-10** are to be regarded as standard. The values given in parentheses are for information only.

1.3 The following safety hazards caveat pertains only to the Specimen Preparation Section, Section 9, and the Test Methods Section, Section 10, of this specification: *This standard does not purport to address all of the safety concerns, if any, associated with its use. It is the responsibility of the user of this standard to establish appropriate safety and health practices and determine the applicability of regulatory limitations prior to use.* See Warning note in 9.1.1 for a specific hazards statement.

NOTE 1—Information in this specification is technically equivalent to related information in ISO 12086-1 and ISO 12086-2.

2. Referenced Documents

2.1 ASTM Standards:³

D618 Practice for Conditioning Plastics for Testing

D638 Test Method for Tensile Properties of Plastics

D792 Test Methods for Density and Specific Gravity (Relative Density) of Plastics by Displacement

D883 Terminology Relating to Plastics

D1895 Test Methods for Apparent Density, Bulk Factor, and Pourability of Plastic Materials

D3892 Practice for Packaging/Packing of Plastics

D4052 Test Method for Density, Relative Density, and API Gravity of Liquids by Digital Density Meter

D4441 Specification for Aqueous Dispersions of Polytetrafluoroethylene

D4591 Test Method for Determining Temperatures and Heats of Transitions of Fluoropolymers by Differential Scanning Calorimetry

D4894 Specification for Polytetrafluoroethylene (PTFE) Granular Molding and Ram Extrusion Materials

¹ This specification is under the jurisdiction of ASTM Committee D20 on Plastics and is the direct responsibility of Subcommittee D20.15 on Thermoplastic Materials. Current edition approved July 1, 2010/May 1, 2015. Published August 2010/June 2015. Originally approved in 1989. Last previous edition approved in 2004/2010 as D4895 - 04-D4895 - 10. DOI: 10.1520/D4895-10.10.1520/D4895-15.

² Specifications for other forms of polytetrafluoroethylene are found in Specifications D4441 and D4894.

³ For referenced ASTM standards, visit the ASTM website, www.astm.org, or contact ASTM Customer Service at service@astm.org. For Annual Book of ASTM Standards volume information, refer to the standard's Document Summary page on the ASTM website.

*A Summary of Changes section appears at the end of this standard

[E11 Specification for Woven Wire Test Sieve Cloth and Test Sieves](#)

[E29 Practice for Using Significant Digits in Test Data to Determine Conformance with Specifications](#)

[E177 Practice for Use of the Terms Precision and Bias in ASTM Test Methods](#)

[IEEE/ASTM SI-10 Use of the International System of Units \(SI\): The Modern Metric System](#)

2.2 *ISO Standards*:⁴

[ISO 12086-1 Plastics Fluoropolymer Dispersions and Molding and Extrusion Materials—Part 1: Designation and Specification](#)

[ISO 12086-2 Plastics Fluoropolymer Dispersions and Molding and Extrusion Materials—Part 2: Preparation of Test Specimens and Determination of Properties](#)

[ISO 13322-2 Particle size analysis—Image analysis methods—Part 2: Dynamic image analysis methods](#)

3. Terminology

3.1 *Definitions*—The definitions given in Terminology [D883](#) are applicable to this specification.

3.2 *Definitions of Terms Specific to This Standard*:

3.2.1 *bulk density, n*—the mass in grams per litre of resin measured under the conditions of the test.

3.2.2 *extended specific gravity (ESG), n*—the specific gravity of a specimen of PTFE material molded as described in this specification and sintered (see [3.2.7](#)) for an extended period of time, compared to the sintering time for the measurement of SSG (see [3.2.8](#)), using the appropriate sintering schedule given in this specification.

3.2.3 *lot, n*—one production run or a uniform blend of two or more production runs.

3.2.4 *preforming, vb*—compacting powdered PTFE material under pressure in a mold to produce a solid object, called a preform, that is capable of being handled. Molding and compaction are terms used interchangeably with preforming for PTFE.

3.2.5 *reground resin, n*—resin produced by grinding PTFE material that has been preformed but has never been sintered.

3.2.6 *reprocessed resin, n*—resin produced by grinding PTFE material that has been preformed and sintered.

3.2.7 *sintering, n*—as it applies to PTFE, a thermal treatment during which the PTFE is melted and recrystallized by cooling with coalescence occurring during the treatment.

3.2.8 *standard specific gravity (SSG), n*—the specific gravity of a specimen of PTFE material molded as described in this specification and sintered using the appropriate sintering schedule given in this specification.

3.2.9 *strained specific gravity (strained SG), n*—the specific gravity of a specimen of PTFE material molded, sintered, and strained as described in this specification.

3.2.10 *stretching void index (SVI), n*—a measure of the change in specific gravity of PTFE material which has been subjected to tensile strain as described in this specification.

3.2.11 *thermal instability index (TII), n*—a measure of the decrease in molecular weight of PTFE material which has been heated for a prolonged period of time.

3.2.12 *unstrained specific gravity (USG), n*—the specific gravity, prior to straining, of a specimen of PTFE material used in the Stretching Void Index Test (see [10.9](#)) of this specification.

4. Classification

4.1 This specification covers the following types of PTFE:

4.1.1 *Type I and Type II*—Resin produced from dispersion and normally used with a volatile processing aid. Each type of resin has the same requirements for bulk density, particle size, water content, melting peak temperature, tensile, and elongation. Each type of resin is divided into grades in accordance with standard specific gravity (SSG), Thermal Stability Index (TII), and Stretching Void Index (SVI). Grades are divided into classes according to extrusion pressure.

NOTE 2—See [Tables 1 and 2](#) for details about grades and classes.

⁴ Available from American National Standards Institute (ANSI), 25 W. 43rd St., 4th Floor, New York, NY 10036, <http://www.ansi.org>.

TABLE 1 Detail Requirements for all Types,^A Grades and Classes

Type	Bulk Density, g/L	Particle Size Average Diameter, μm	Water Content, max, %	Melting Peak Temperature, °C		Tensile Strength, min, MPa	Elongation at Break, min, %
				Initial	Second		
I	550 ± 150	500 ± 200	0.04	^B	327 ± 10	19	200
II	550 ± 150	1050 ± 350	0.04	^B	327 ± 10	19	200

^AThe types, grades, and classes are not the same as those in previous editions of Specification D4895.

^BGreater than 5.0°C above the second melting peak temperature.

TABLE 2 Detail Requirements for All Types,^A Grades and Classes

Type	Grade	Class	Standard Specific Gravity		Extrusion Pressure, MPa	Thermal Instability Index, max	Stretching Void Index, max
			min	max			
I	1	A	2.14	2.18	5 to <15 ^B	50	NA ^C
		B	2.14	2.18	15 to <55 ^D	50	NA ^C
		C	2.14	2.18	15 to <75 ^E	50	NA ^C
	2	A	2.17	2.25	5 to <15 ^B	50	NA ^C
		B	2.17	2.25	15 to <55 ^D	50	NA ^C
		C	2.17	2.25	15 to <75 ^E	50	NA ^C
	3	C	2.15	2.19	15 to <75 ^E	15	200
		D	2.15	2.19	15 to <65 ^E	15	100
		E	2.15	2.19	15 to <65 ^E	50	200
4	B	2.14	2.16	15 to <55 ^D	15	50	
	A	2.14	2.25	5 to <15 ^B	50	NA ^C	
II	1	A	2.14	2.25	5 to <15 ^B	50	NA ^C

^AThe types, grades, and classes are not the same as those in previous editions of Specification D4895.

^BTested at a reduction ratio of 100:1 (reduction ratio is the ratio of the cross-sectional area of the preform to the cross-sectional area of the die).

^CNot applicable.

^DTested at a reduction ratio of 400:1.

^ETested at a reduction ratio of 1600:1.

4.2 A line callout system is used to specify materials in this specification. The system uses predefined cells to refer to specific aspects of this specification, as illustrated as follows:

Specification				
Standard Number Block	Type	Grade	Class	Special Notes
Example: Specification D4895 - XX	I	2	C	

For this example, the line callout would be Specification D4895 - XX, I2C, and would specify a coagulated dispersion form of polytetrafluoroethylene that has all of the properties listed for that type, grade, and class in the appropriate specified properties or tables, or both, in the specification identified. A comma is used as the separator between the standard number and the type. Separators are not needed between the type, grade, and class.⁵

5. Mechanical Properties

5.1 The resins covered by this specification shall be in accordance with the requirements prescribed in **Tables 1 and 2**, when tested by the procedures specified herein.

6. Other Requirements

6.1 The resin shall be uniform and shall contain no additives or foreign material.

6.2 The color of the material as shipped by the supplier shall be natural white.

6.3 For purposes of determining conformance, all specified limits for this classification system are absolute limits, as defined in Practice **E29**.

6.3.1 With the absolute method, an observed value is not rounded, but is to be compared directly with the limiting value. Example: In **Table 2** Type I, Grade 4, Class B, under Specific Gravity, 2.14 shall be considered as 2.140000 and 2.16 shall be considered 2.160000.

7. Sampling

7.1 Sampling shall be statistically adequate to satisfy the requirements in Section **11**.

8. Number of Tests

8.1 Lot inspection shall include tests for bulk density, particle size, and extrusion pressure. Periodic tests shall consist of all the tests specified in **Tables 1 and 2** and shall be made at least once per year.

⁵ See the **ASTM Form and Style Manual for ASTM Standards manual**, available from ASTM Headquarters.

8.2 The tests listed in Tables 1 and 2, as they apply, are sufficient to establish conformity of a material to this specification. One set of test specimens as prescribed in Section 9 shall be considered sufficient for testing each sample. The average of the results for the specimens tested shall conform to the requirements of this specification.

9. Specimen Preparation

9.1 Test Disks for Tensile Properties:

9.1.1 Use the die shown in Fig. 1 for the molding of test disks (see Note 2). Place flat aluminum disks, 0.1 to 0.4 mm (0.004 in. to 0.016 in.) thick and 76 mm (3 in.) in diameter, on both sides of the resin. The test resin shall be near ambient temperature prior to molding (see Note 3). (Warning—PTFE resins can evolve small quantities of gaseous products when heated above 204°C (400°F). Some of these gases are harmful. Consequently, exhaust ventilation must be used whenever these resins are heated above this temperature, as they are during the sintering operations that are a part of this specification. Since the temperature of burning tobacco exceeds 204°C (400°F), those working with PTFE resins shall ensure that tobacco is not contaminated.)

NOTE 3—For maximum precision, these weighing and preforming operations shall be carried out at 23 ± 2°C (73.4 ± 3.6°F) (the “near ambient” temperature referred to herein). These operations shall not be performed at temperatures below 21°C (70°F) due to the crystalline transition that occurs in PTFE in this temperature region which leads to possible cracks in sintered specimens and differences in specimen density (as well as changes in other physical properties). Problems caused by the effect of temperature on the specific gravity or density of PTFE shall be minimized when the measurement is made using immersion procedures if a sensitive thermometer (for example, one reading ± 0.1°C) is used in the liquid and the temperature is adjusted to be at least 22°C.

9.1.2 Screen 14.5 g of PTFE resin through a No. 10 sieve into the die. Adjust the lower plug height to allow the resin in the die can be leveled by drawing a straightedge in contact with the top of the die across the top of the die cavity. Insert the die in a suitable hydraulic press and apply pressure gradually (see Note 4) until a pressure of 14 MPa (2030 psi) is attained. Hold this pressure for 3 min. Remove the disk from the die. Write the sample identification number on the preform using an appropriate marker that will not effectaffect the PTFE during sintering.

NOTE 4—As a guide, increasing the pressure at a rate of 3.5 MPa (500 psi)/min is suggested until the desired maximum pressure is attained.

9.1.3 Place the sintering oven in a laboratory hood (or equip it with an adequate exhaust system) and sinter the preforms in accordance with Table 3, Procedure A (see Note 5).

NOTE 5—Although the rate of heat application is not critical, the cooling cycle is most important and the conditions cited in this procedure must be followed very closely. If they are not followed, the crystallinity of the disks and the resulting physical properties will be markedly changed. Therefore,

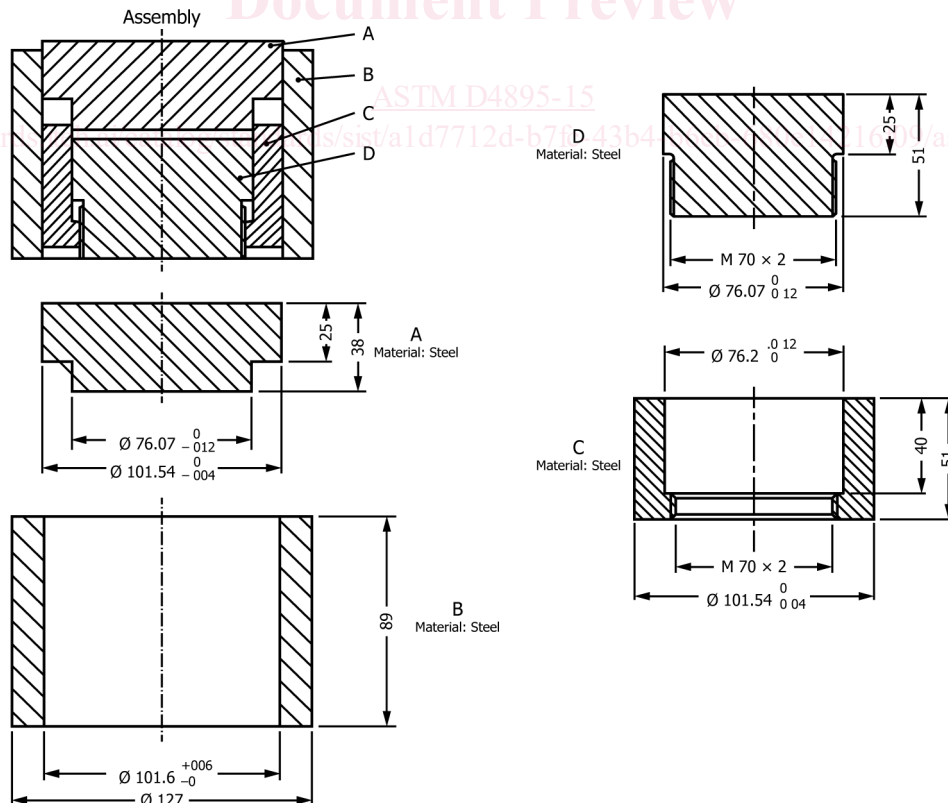

NOTE 1—All dimensions are in millimetres.

FIG. 1 Mold Assembly for the Preparation of Specimens for the Determination of Tensile Properties

TABLE 3 Sintering Procedures

	A	B
Initial temperature, °C (°F)	290 (554)	290 (554)
Rate of heating, °C/h (°F/h)	120 ± 10 (216 ± 18)	120 ± 10 (216 ± 18)
Hold temperature, °C (°F)	380 ± 6 (716 ± 10)	380 ± 6 (716 ± 10)
Hold time, min	30 + 2, -0	360 ± 5
Cooling rate, °C/h (°F/h)	60 ± 5 (108 ± 9)	60 ± 5 (108 ± 9)
Second hold temperature, °C (°F)	294 ± 6 (561 ± 10)	294 ± 6 (561 ± 10)
Second hold time, min	24 + 0.5, -0	24 + 0.5, -0
Period to room temperature, min	≥30	≥30

the use of a programmed oven is recommended for the most precise sintering cycle control and the hood window shall be left down during the entire sintering procedure, the latter being an important safety consideration.

9.2 Test Specimens for Standard Specific Gravity and Thermal Instability Index:

9.2.1 A cylindrical preforming mold, 29-mm (1.14-in.) internal diameter by at least 76 mm (3 in.) deep, is used to prepare the preforms. Clearance shall be sufficient to ensure escape of air during pressing. Place flat aluminum foil disks, normally 0.13 mm (0.005 in.) thick and 29 mm (1.14 in.) in diameter on both sides of the resin. The test resin shall be near ambient temperature prior to molding (see [Note 3](#)).

9.2.2 Weigh out 12.0 ± 0.1 g of resin and place it in the die. Screen ~~non-freeflowing~~ resins through a No. 10 sieve. Compacted resins shall be broken up by hand-shaking cold resin in a half-filled sealed glass container. Condition the resin in the sealed glass container in a freezer or dry-ice chest. After breaking up resin lumps, allow the sealed container to equilibrate to near ambient temperature. Then screen and weigh the 12.0 ± 0.1 -g sample. Insert the die in a suitable hydraulic press and apply pressure gradually (see [Note 4](#)) until a pressure of 14 MPa (2030 psi) is attained. Hold this pressure for 2 min. Remove the preform from the die. Write the sample identification number on the preform using an appropriate marker that will not effect the PTFE during sintering.

9.2.3 Sinter the preforms in accordance with [Table 3](#) (see [Note 5](#)).

9.2.3.1 For SSG specimens use Procedure A.

9.2.3.2 For ESG specimens use Procedure B.

NOTE 6—Improved precision in SSG and ESG test results has been obtained with the use of an upright, cylindrical oven and an aluminum sintering rack. The cylindrical oven has an inside diameter of 140 mm (5.5 in.) and an inside depth of 203 mm (8 in.) plus additional depth to accommodate a 51-mm (2-in.) thick cover, and is equipped with suitable heaters and controllers to sinter specimens in accordance with the procedures in [Table 3](#). The rack, as shown in [Fig. 2](#), allows preforms to be placed symmetrically in the center region of the oven. Place six preforms on each of the middle oven rack shelves (if six or fewer preforms are to be sintered, place them on the middle rack, filling in with “dummies” as needed). Place “dummies” on the top and bottom shelves. Specimens must be spaced evenly in a circle on each shelf, with none of them touching. An oven load must be no less than 18 pieces including “dummies.” “Dummies” are defined as normal 12-g specimens that have previously been through the sintering cycle. “Dummies” must only be used for an additional two or three thermal cycles, due to eventual loss of thermal stability and physical form.

9.2.4 Remove all flash from each specimen so that no air bubbles will cling to the edges when the specimen is immersed in the solution for weighing during the standard specific gravity and thermal instability index tests. It is recommended for this section and during testing that cotton gloves be worn while handling test specimens.

9.3 Test Disks for Stretching Void Index (SVI):

9.3.1 Mold the disk as in [9.1.1](#).

9.3.2 Screen 29 g of PTFE resin through a 2.00-mm (No. 10) sieve into the die. Adjust the lower plug to allow the resin to be leveled by drawing a straightedge in contact with the top of the die across the top of the die cavity. Insert the die in a suitable hydraulic press and apply pressure gradually (see [Note 4](#)) until a pressure of 7 MPa (1015 psi) is attained. Hold this pressure for 2 min, then increase the pressure to 14 MPa (2030 psi) and hold for an additional 2 min. Remove the disk from the die. Write the sample identification number on the preform using an appropriate marker that will not effect the PTFE during sintering.

9.3.3 Sinter the preforms in accordance with [Table 3](#), Procedure A (see [Note 5](#)).

9.3.4 Remove all flash from those portions of these specimens that will be used for determination of specific gravities so that no air bubbles will cling to their edges when the specimens are immersed in liquid during these tests. It is recommended that cotton gloves be worn while handling test specimens.

9.4 Conditioning Test Specimens:

9.4.1 For tests of tensile properties and all tests requiring the measurement of specific gravities, condition the test specimens in general accordance with Procedure A of Practice [D618](#), with the following deviations therefrom: (1) the aging period shall be a minimum of 4 h immediately prior to testing, (2) the laboratory temperature shall be $23 \pm 2^\circ\text{C}$ ($73.4 \pm 3.6^\circ\text{F}$), and (3) there shall be no requirement respecting humidity. The other tests require no conditioning of the molded test specimens.

9.5 Test Conditions:

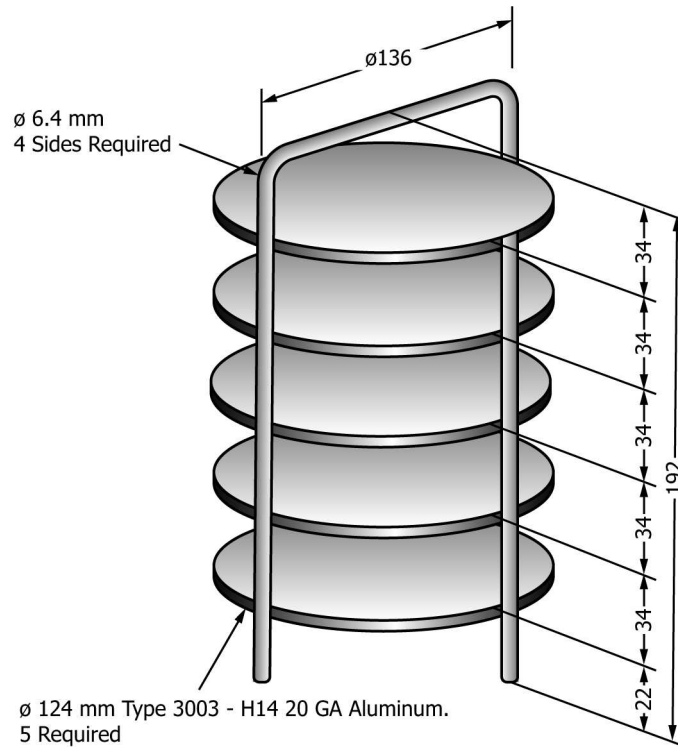

NOTE 1—Aluminum plates tack welded to rods.
 NOTE 2—All dimensions are in millimetres.

FIG. 2 Sintering Rack for SSG Specimens

9.5.1 Tests shall be conducted at the standard laboratory temperature of $23 \pm 2^\circ\text{C}$ ($73.4 \pm 3.6^\circ\text{F}$), unless otherwise specified in the test methods or in this specification. This deviation from the standard laboratory temperature is made because of the necessity for maintaining test temperatures above approximately 21°C (70°F). See Note 3 for additional details. Since these resins do not absorb water, the maintenance of constant humidity during testing is not required.

10. Test Methods

10.1 Melting Characteristics by Thermal Analysis:

10.1.1 Significance and Use—For PTFE resins that have been melted prior to use, the melting peak temperature characteristics of a resin provide important information about the thermal history of the material. Melting peak temperatures (see Fig. 3) are used to determine conformance of a resin to the melting peak temperature requirements in Table 1 of this specification.

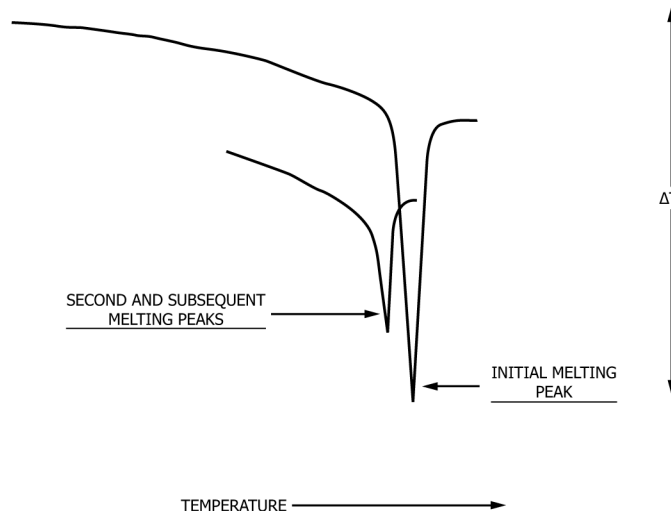

FIG. 3 Melting Characteristics by Thermal Analysis