



Designation: D4530 – 15

Standard Test Method for Determination of Carbon Residue (Micro Method)¹

This standard is issued under the fixed designation D4530; the number immediately following the designation indicates the year of original adoption or, in the case of revision, the year of last revision. A number in parentheses indicates the year of last reapproval. A superscript epsilon (ϵ) indicates an editorial change since the last revision or reapproval.

This standard has been approved for use by agencies of the U.S. Department of Defense.

1. Scope*

1.1 This test method covers the determination of the amount of carbon residue (see [Note 1](#)) formed after evaporation and pyrolysis of petroleum materials under certain conditions and is intended to provide some indication of the relative coke forming tendency of such materials.

1.2 The test results are equivalent to the Conradson Carbon Residue test (see Test Method [D189](#)).

NOTE 1—This procedure is a modification of the original method and apparatus for carbon residue of petroleum materials, where it has been demonstrated that thermogravimetry is another applicable technique.² However, it is the responsibility of the operator to establish operating conditions to obtain equivalent results when using thermogravimetry.

1.3 This test method is applicable to petroleum products that partially decompose on distillation at atmospheric pressure and was tested for carbon residue values of 0.10 % to 30 % (m/m). Samples expected to be below 0.10 weight % (m/m) residue should be distilled to remove 90 % (V/V) of the flask charge (see Section 9). The 10 % bottoms remaining is then tested for carbon residue by this test method.

1.4 Ash-forming constituents, as defined by Test Method [D482](#), or non-volatile additives present in the sample will add to the carbon residue value and be included as part of the total carbon residue value reported.

1.5 Also in diesel fuel, the presence of alkyl nitrates, such as amyl nitrate, hexyl nitrate, or octyl nitrate, causes a higher carbon residue value than observed in untreated fuel, which may lead to erroneous conclusions as to the coke-forming propensity of the fuel. The presence of alkyl nitrate in the fuel may be detected by Test Method [D4046](#).

1.6 The values stated in SI units are to be regarded as standard. No other units of measurement are included in this standard.

1.6.1 *Exception*—[6.4](#) and [6.5](#) include inch-pound units.

¹ This test method is under the jurisdiction of ASTM Committee [D02](#) on Petroleum Products, Liquid Fuels, and Lubricants and is the direct responsibility of Subcommittee [D02.06](#) on Analysis of Liquid Fuels and Lubricants.

Current edition approved June 1, 2015. Published June 2015. Originally approved in 1985. Last previous edition approved in 2011 as D4530 – 11. DOI: 10.1520/D4530-115.

² See [Fuel](#), Vol 63, July 1984, pp. 931–934.

1.7 **WARNING**—Mercury has been designated by many regulatory agencies as a hazardous material that can cause central nervous system, kidney and liver damage. Mercury, or its vapor, may be hazardous to health and corrosive to materials. Caution should be taken when handling mercury and mercury containing products. See the applicable product Material Safety Data Sheet (MSDS) for details and EPA's website—<http://www.epa.gov/mercury/faq.htm>—for additional information. Users should be aware that selling mercury and/or mercury containing products into your state or country may be prohibited by law.

1.8 *This standard does not purport to address all of the safety concerns, if any, associated with its use. It is the responsibility of the user of this standard to establish appropriate safety practices and to determine the applicability of regulatory limitations prior to use.* For specific warning statements, see [8.2.3](#) and [8.4](#).

2. Referenced Documents

2.1 ASTM Standards:³

[D189](#) Test Method for Conradson Carbon Residue of Petroleum Products

[D482](#) Test Method for Ash from Petroleum Products

[D4046](#) Test Method for Alkyl Nitrate in Diesel Fuels by Spectrophotometry

[D4057](#) Practice for Manual Sampling of Petroleum and Petroleum Products

[D4177](#) Practice for Automatic Sampling of Petroleum and Petroleum Products

[E1](#) Specification for ASTM Liquid-in-Glass Thermometers

[E133](#) Specification for Distillation Equipment

2.2 Energy Institute Standard:

[Specification for IP Standard Thermometers](#)⁴

3. Terminology

3.1 Definitions:

³ For referenced ASTM standards, visit the ASTM website, www.astm.org, or contact ASTM Customer Service at service@astm.org. For *Annual Book of ASTM Standards* volume information, refer to the standard's Document Summary page on the ASTM website.

⁴ "Methods for Analysis and Testing," *Institute of Petroleum Standard Methods for Petroleum and Its Products*, Part I, Vol 2. Available from Energy Institute, 61 New Cavendish St., London, WIM 8AR, UK.

*A Summary of Changes section appears at the end of this standard

3.1.1 *carbon residue, n*—the residue formed by evaporation and thermal degradation of a carbon containing material.

3.1.1.1 *Discussion*—The residue is not composed entirely of carbon but is a coke that can be further changed by carbon pyrolysis.

4. Summary of Test Method

4.1 A weighed quantity of sample is placed in a glass vial and heated to 500 °C under an inert (nitrogen) atmosphere in a controlled manner for a specific time. The sample undergoes coking reactions, and volatiles formed are swept away by the nitrogen. The carbonaceous-type residue remaining is reported as a percent of the original sample as “carbon residue (micro).”

4.1.1 When the test result is expected to be below 0.10 % (m/m), the sample can be distilled to produce a 10 % (V/V) bottoms, prior to performing the test.

5. Significance and Use

5.1 The carbon residue value of the various petroleum materials serves as an approximation of the tendency of the material to form carbonaceous type deposits under degradation conditions similar to those used in the test method, and can be useful as a guide in manufacture of certain stocks. However, care needs to be exercised in interpreting the results.

5.2 This test method offers advantages of better control of test conditions, smaller samples, and less operator attention compared to Test Method D189, to which it is equivalent.

5.3 Up to twelve samples may be run simultaneously, including a control sample when the vial holder shown in Fig. 1 is used exclusively for sample analysis.

6. Apparatus

6.1 *Glass Sample Vials*, 2 mL capacity, 12 mm outside diameter by approximately 35 mm high.

6.2 *Larger 4-dram Glass Sample Vials*, 15 mL capacity (20.5 mm to 21 mm outside diameter by 70 mm ± 1 mm high), may be used for samples that are expected to yield residues <0.10 % (m/m) so that a more appreciable mass difference can be determined. It should be noted the precision statements for the test method were determined using the 2 mL capacity vials only (with sample residues between 0.3 % and 26 % (m/m) and that the precision associated with using the larger sample vials has not been determined.

6.3 *Eyedropper, Syringe, or Small Rod*, for sample transfer.

6.4 *Coking Oven* with circular heating chamber approximately 85 mm (3 3/8 in.) in diameter by 100 mm (4 in.) deep, for top loading, with heating capability from 10 °C/min to 40 °C/min rate to 500 °C, with exhaust port 13 mm (1/2 in.) inside diameter for nitrogen purge of oven chamber (inlet near top, exhaust at bottom center) with thermocouple sensor located in oven chamber next to but not touching sample vials, with lid capable of sealing out air, and with removable condensate trap located at the oven chamber base. A schematic diagram is given in Fig. 2.

6.5 *Sample Vial Holder*—Cylindrical aluminum block, approximately 76 mm (3 in.) in diameter by 16 mm (5/8 in.) thick, with twelve evenly spaced holes (for vials) each 13 mm (1/2 in.) in diameter by 13 mm (1/2 in.) deep. The holes are arranged in a circular pattern approximately 3 mm (1/8 in.) from the perimeter. The holder has legs 6 mm (1/4 in.) long, with guides to

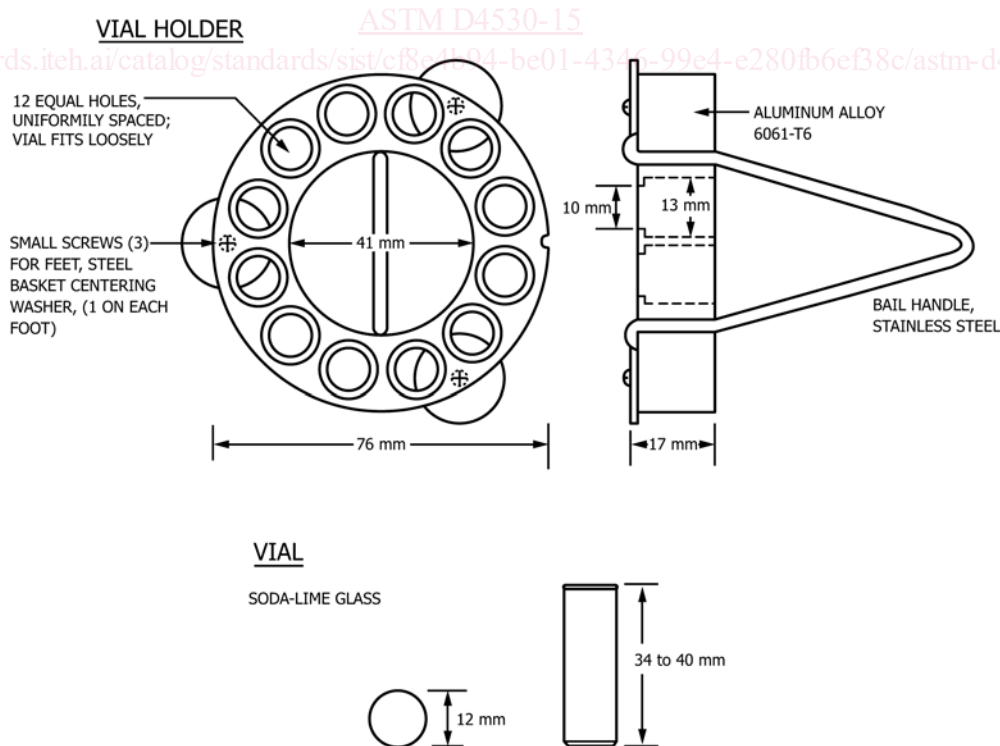

FIG. 1 Sample Vial Holder and Vial

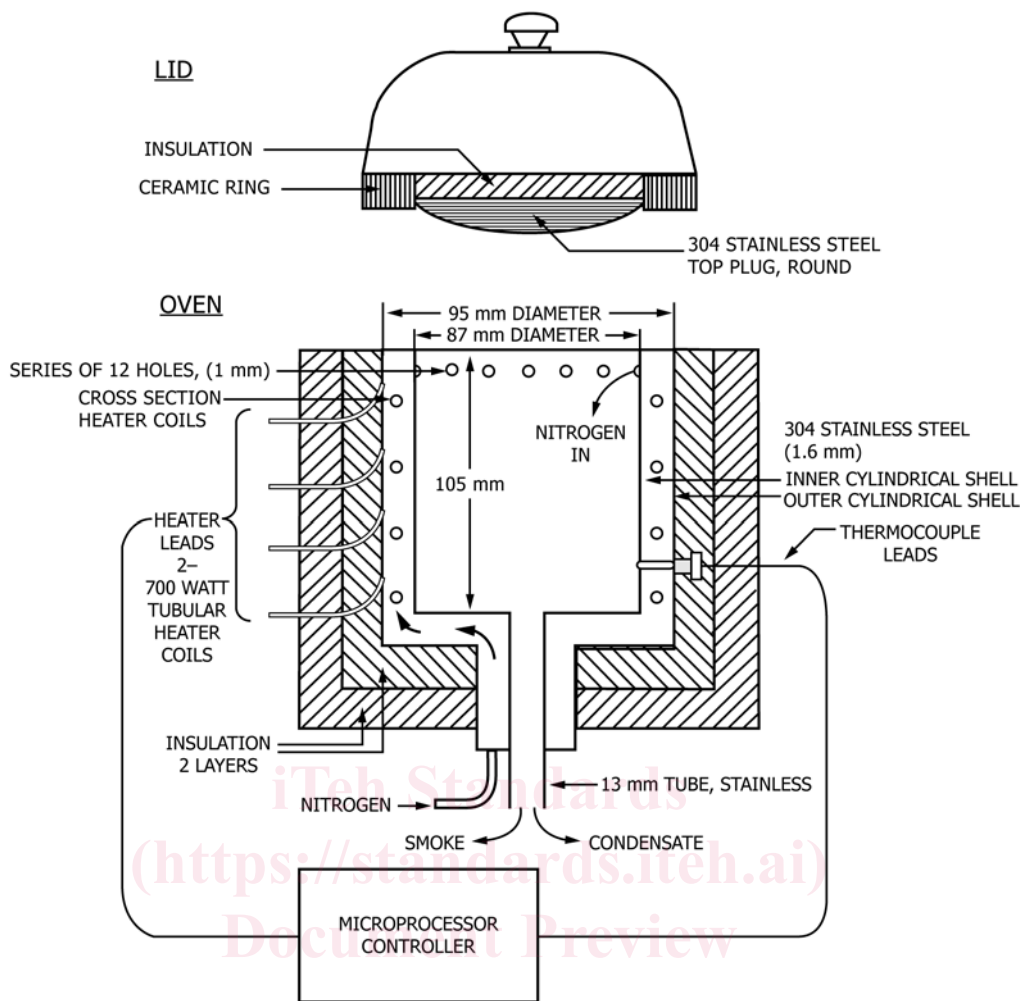

FIG. 2 Coking Oven and Lid

center in oven chamber, and an index mark on the side to use as position reference. The sample vial holder is shown in Fig. 1.

6.6 A modified version of the standard sample vial holder (see Fig. 1) is required when larger glass sample vials (see 6.2) are used. The modified sample vial holder is similar in nature to the twelve hole vial holder, except that there are six evenly spaced holes (for vials) each $21.2 \text{ mm} \pm 0.1 \text{ mm}$ in diameter by approximately 16 mm deep, arranged in a circular pattern.

6.7 *Thermocouple*, suitable for controller and temperature range of interest, with exterior temperature readout, degrees Celsius.

6.8 *Analytical Balance*, with $\pm 0.1 \text{ mg}$ sensitivity to 20 g minimum weighing capacity.

6.9 *Nitrogen*, minimum 99.998 % purity with suitable means of delivering a pressure of 0 kPa to 200 kPa (0 psig to 30 psig). Cylinders of zero grade nitrogen have been found suitable to use.

7. Sampling

7.1 Using the practices outlined in Practice D4057 (manual sampling) or Practice D4177 (automatic sampling), ensure that a representative sample of material to be tested is obtained.

8. Procedure

8.1 Sample Preparation:

8.1.1 Determine the mass of each clean sample vial being used in the sample analysis, and record the mass to nearest 0.1 mg.

8.1.2 During weighing and filling, handle vials with forceps to help minimize weighing errors. Discard the sample vials after use.

8.1.3 It is assumed that a representative sample of the stock or process has been obtained for laboratory use following Practice D4057 or similar standard. Stir the sample to be tested, first warming if necessary to reduce its viscosity. Samples that are homogeneous liquids can be transferred directly to vials using a rod, syringe, or eyedropper. Solid materials may also be heated; or frozen with liquid nitrogen, and then shattered to provide manageable pieces.

8.1.4 Transfer an appropriate mass of the sample (see Table 1) into a tared-sample vial, reweigh to nearest 0.1 mg, and record. Place the loaded sample vials into vial holder (up to twelve), noting position of each sample with respect to index mark.

NOTE 2—A control sample can be included in each batch of samples being tested. This control sample should be a typical sample that has been