



Standard Consumer Safety Specification for Toy Safety¹

This standard is issued under the fixed designation F 963; the number immediately following the designation indicates the year of original adoption or, in the case of revision, the year of last revision. A number in parentheses indicates the year of last reapproval. A superscript epsilon (ϵ) indicates an editorial change since the last revision or reapproval.

^{ε1} NOTE—In 5.10.1.2, the signal word type sizes were editorially corrected in February 2002. Paragraph 8.16.4 was corrected editorially in February 2002. Figures have been renumbered editorially since the original printing of this specification.

^{ε2} NOTE—The warning symbols in section 5 were editorially corrected in May 2002.

INTRODUCTION

The purpose of this consumer safety specification is to establish nationally recognized safety requirements for toys. Although this specification will not eliminate the need for the exercise of parental responsibility in selecting toys appropriate to the age of a child, or parental supervision in situations in which children of various ages may have access to the same toys, its application will minimize accidents in the normal, intended use and reasonably foreseeable abuse of the toys covered by this specification. This specification was developed originally as a Voluntary Product Standard under the auspices of the National Bureau of Standards, Department of Commerce, and published in 1976 (PS 72–76). The present revision is intended to update the safety requirements to include the following by reference: published federal mandatory requirements, relevant voluntary standards, certain new requirements for addressing potential hazards, and several technical revisions based on producer experience with the original standard. In addition, where appropriate, test criteria have been updated to reflect more current anthropometric data on U.S. children.

1. Scope

1.1 This specification² relates to possible hazards that may not be recognized readily by the public and that may be encountered in the normal use for which a toy is intended or after reasonably foreseeable abuse. It does not purport to cover every conceivable hazard of a particular toy. This specification does not cover product performance or quality, except as related to safety. Except for the labeling requirements pointing out the functional hazards and age range for which the toy is intended, this specification has no requirements for those aspects of a toy that present an inherent and recognized hazard as part of the function of the toy. Such an example is a sharp point necessary for the function of a needle. The needle is an inherent hazard that is well understood by the purchaser of a toy sewing kit, and this hazard is communicated to the user as part of the normal educational process.

1.2 On the other hand, while a riding toy has inherent hazards associated with its use (for example, falling off onto the sidewalk), the possible hazards associated with its construction (sharp edges, exposed mechanisms, etc.) will be minimized by the application of this specification.

1.3 This specification covers requirements and contains test methods for toys intended for use by children in age groups through 14 years. Different age limits for various requirements will be found in this specification. These limits reflect the nature of the hazards and expected mental or physical ability, or both, of a child to cope with the hazards.

1.4 Articles not covered by this specification are as follows:

- Bicycles
- Tricycles
- Sling shots and sharp-pointed darts
- Playground equipment
- Non-powder guns
- Kites

Hobby and craft items in which the finished item is not primarily of play value

Model kits in which the finished item is not primarily of play value

Crayons, paints, chalks, and other similar art materials in which the material itself or the finished item is not primarily of play value, except that all art materials, whether or not a component of a toy, must comply to

¹ This consumer safety specification is under the jurisdiction of ASTM Committee F15 on Consumer Products and is the direct responsibility of Subcommittee F15.22 on Toy Safety.

Current edition approved Nov. 10, 1996. Published January 1997. Originally published as F 963 – 86. Last previous edition F 963 – 95.

² The rationale for this specification may be obtained from ASTM Headquarters. Request RR:F15 – 1000. The Toy Manufacturers of America, Inc. (TMA) can provide its interpretations of this specification through its General Counsel as a service to its members and others. The TMA's interpretations are not reviewed or approved by ASTM and should be viewed as TMA's alone.

LHAMA, in accordance with 4.31.1-4.31.3.

Sporting goods, camping goods, athletic equipment, musical instruments, and furniture; however, toys that are their counterparts are covered. (It is recognized that there is often a fine line between, for example, a musical instrument or a sporting item and its toy counterpart. The intention of the producer or distributor, as well as normal use and reasonably foreseeable abuse, determines whether the item is a toy counterpart.)

Powered models of aircraft, rockets, boats, and land vehicles; however, toys that are their counterparts are covered.

1.5 General guidelines for age labeling toys and toy packaging are contained in Annex A1.

1.6 Information regarding packaging and shipping is contained in Annex A2. A table to serve as a guide to the requirements contained in this specification, as applicable to various toy categories, is provided in Annex A3.

1.7 This consumer safety specification includes the following sections:

Title	Section
Scope	1
Referenced Documents	2
Terminology	3
Safety Requirements	4
Material Quality	4.1
Flammability	4.2
Toxicology	4.3
Electrical/Thermal Energy	4.4
Impulsive Noise	4.5
Small Objects	4.6
Accessible Edges	4.7
Accessible Points	4.8
Projections	4.9
Nails and Fasteners	4.10
Wires or Rods	4.11
Packaging Film	4.12
Cords and Elastics	4.13
Wheels, Tires, and Axles	4.14
Folding Mechanisms and Hinges	4.15
Holes, Clearance, and Accessibility of Mechanisms	4.16
Stability and Over-Load Requirements	4.17
Confined Spaces	4.18
Simulated Protective Devices	4.19
Projectile Toys	4.20
Rattles	4.21
Pacifiers	4.22
Squeeze Toys	4.23
Teethers and Teething Toys	4.24
Toys Intended to be Attached to a Crib or Playpen	4.25
Toy Chests	4.26
Battery-Operated Toys	4.27
Flotation Toys	4.28
Stroller and Carriage Toys	4.29
Stuffed and Beanbag-Type Toys	4.30
Art Materials	4.31
Toy Gun Marking	4.32
Balloons	4.33
Marbles	4.34
Balls	4.35
Preschool Play Figures	4.36
Pompoms	4.37
Safety Labeling Requirements	5
Instructional Literature	6
Producer's Markings	7
Test Methods	8
General	8.1
Testing for Hazardous Substance Content	8.2
Method to Dissolve Soluble Matter	8.3
Tests for Cleanliness and Preservative Effectiveness	8.4

Normal Use Testing	8.5
Abuse Testing	8.6
Impact Tests	8.7
Torque Tests for Removal of Components	8.8
Tension Test for Removal of Components	8.9
Compression Test	8.10
Tests for Tire Removal and Snap-in Wheel and Axle Assembly Removal	8.11
Flexure Test	8.12
Test for Mouth-Actuated Toys	8.13
Tests for Toy Chest Lids and Closures	8.14
Projectiles	8.15
Test for Stability of Ride-On Toys	8.16
Identification	9
Age Grading Guidelines	Annex A1
Packaging and Shipping	Annex A2
Requirements Guide by Toy Categories	Annex A3
Design Guidelines for Toys Attached to Cribs or Playpens	Annex A4
Flammability Testing Procedure for Toys	Annex A5

1.8 The values stated in inch-pound units are to be regarded as the standard. The values given in parentheses are for information only.

1.9 The following precautionary statement pertains only to the test methods portion, Section 7, of this specification: *This standard does not purport to address all of the safety concerns, if any, associated with its use. It is the responsibility of the user of this standard to establish appropriate safety and health practices and determine the applicability of regulatory limitations prior to use.*

2. Referenced Documents

2.1 ASTM Standards:

- D 374 Test Methods for Thickness of Solid Electrical Insulation³
- D 642 Test Method for Determining Compressive Resistance of Shipping Containers, Components, and Unit Loads⁴
- D 775 Test Method for Drop Test for Loaded Boxes⁵
- D 880 Test Method for Impact Testing for Shipping Containers and Systems⁴
- D 999 Methods for Vibration Testing of Shipping Containers⁴
- D 1193 Specification for Reagent Water⁶
- D 2240 Test Method for Rubber Property—Durometer Hardness⁷
- D 3421 Practice for Extraction and Determination of Plasticizer Mixtures from Vinyl Chloride Plastics⁸
- D 4236 Practice for Labeling Art Materials for Chronic Health Hazards⁹
- F 1313 Specification for Volatile *n*-Nitrosamine Levels in Rubber Nipples on Pacifiers¹⁰

³ Annual Book of ASTM Standards, Vol 10.01.

⁴ Annual Book of ASTM Standards, Vol 15.09.

⁵ Discontinued; see 1992 Annual Book of ASTM Standards, Vol 15.09.

⁶ Annual Book of ASTM Standards, Vol 11.01.

⁷ Annual Book of ASTM Standards, Vol 09.01.

⁸ Discontinued; see 1986 Annual Book of ASTM Standards, Vol 08.03.

⁹ Annual Book of ASTM Standards, Vol 06.02.

¹⁰ Annual Book of ASTM Standards, Vol 15.07.

2.2 *ANSI Standards:*¹¹

C18.1 American National Standard for Dry Cells and Batteries—Specifications

Z315.1 Safety Requirements for Tricycles

2.3 *Federal Standards:*¹²

15 CFR 1150 Marking of Toys, Look-Alike and Imitation Firearms

16 CFR 1303 Ban of Lead-Containing Paint and Certain Consumer Products Bearing Lead Containing Paint

16 CFR 1500 Hazardous Substances Act Regulations, including the following sections:

1500.3 (c) (6) (vi) Definition of “flammable solid”

1500.14(b) (8) Labeling of hazardous art materials

1500.18 Banned toys and other banned articles intended for use by children

1500.19 Misbranded toys and other articles intended for use by children

1500.44 Method for determining extremely flammable and flammable solids

1500.47 Method for determining the sound pressure level produced by toy caps

1500.48 Technical requirements for determining a sharp point in toys and other articles intended for use by children under 8 years of age

1500.49 Technical requirements for determining a sharp metal or glass edge in toys and other articles intended for use by children under 8 years of age

1500.50-53 Test method for simulating use and abuse of toys and other articles intended for use by children

1500.83 Exemptions for small packages, minor hazards, and special circumstances

1500.85 Exemptions from classification as banned hazardous substances

1500.86 Exemptions from classification as a banned toy or other banned article for use by children

16 CFR 1501 Method for Identifying Toys and Other Articles Intended for Use by Children Under 3 Years of Age which Present Choking, Aspiration, or Ingestion Hazards Because of Small Parts

16 CFR 1505 Requirements for Electrically Operated Toys or Other Electrically Operated Articles Intended for Use by Children

16 CFR 1510 Requirements for Rattles

16 CFR 1511 Requirements for Pacifiers

16 CFR 1610 Standard for Flammability of Clothing Textiles

21 CFR 110 Current Good Manufacturing Practice in Manufacturing, Processing, Packaging, or Holding Human Food

21 CFR 170-189 Food for Human Consumption

49 CFR 173.100, 109 Definition of Class C Explosives

SS-T-312B Tile, Floor: Asphalt, Rubber, Vinyl, VinylAsbestos¹³

3. Terminology

3.1 *Definitions of Terms Specific to This Standard:*

3.1.1 *accessible*—any portion of a toy that can be contacted by a probe designated in 16 CFR 1500.48 and 16 CFR 1500.49. The method for using the probe can be found in 16 CFR 1500.48 (c). An illustration of an accessibility probe is shown in Fig. 1.

3.1.1.1 *Discussion*—Dimensions are provided for two probes corresponding to two age ranges of children.

3.1.2 *art material*—any substance marketed or represented by the producer or repackager as suitable for use in any phase of the creation of any work of visual or graphic art of any medium. This definition includes items that become a component of the work of art such as paint, canvas, inks, crayons, chalk, solder, brazing rods, flux, paper, clay, stone, thread, cloth, and photographic film. It also includes items that are associated closely with the creation of the final work of art such as brushes, brush cleaners, solvents, ceramic kilns, silk screens, molds, mold making material, and photographic developing chemicals.

3.1.3 *ball*—any spherical, ovoid, or ellipsoidal object that is designed or intended to be thrown, hit, kicked, rolled, dropped, or bounced. The term “ball” includes any spherical, ovoid, or ellipsoidal object that is attached to a toy or article by means of string, elastic cord, or similar tether. The term “ball” also includes any multisided object formed by connecting planes into a generally spherical ovoid, or ellipsoidal shape that is designated or intended to be used as a ball. The term “ball” does not include dice, or balls permanently enclosed inside pinball machines, mazes, or similar outer containers. A ball is permanently enclosed if, when tested in accordance with 16 CFR 1500.53, it is not removed from the outer container.

3.1.4 *burr*—a roughness that may be found at an edge or joint of a toy or component if the material is not severed or finished cleanly.

3.1.5 *cord*—a length of slender, flexible material including monofilaments, woven and twisted cord, rope, plastic textile tapes, ribbon, and those fibrous materials commonly called string.

3.1.6 *curled edge*—an edge in which the portion of the sheet adjacent to the edge is bent into an arc and forms an angle of less than 90° with the base sheet, as shown in Fig. 2.

3.1.7 *discharge mechanism*—an inanimate system for releasing and propelling a projectile.

3.1.8 *edge, hazardous*—an accessible edge that presents an unreasonable risk of injury during the normal use and reasonably foreseeable abuse of a toy. Metal and glass edges on toys intended for children under the age of eight years are defined as potentially hazardous if they fail the sharp edge test described in 16 CFR 1500.49. Edges other than metal and glass are defined as potentially hazardous if they are sharp to the touch under casual handling conditions.

¹¹ Available from American National Standards Institute, 11 W. 42nd St., 13th Floor, New York, NY 10036.

¹² Available from U.S. Consumer Product Safety Commission, Washington, DC 20207.

¹³ Available from Superintendent of Documents, U.S. Government Printing Office, Washington, DC 20402.

ASTM F 963 – 96a^{e2}

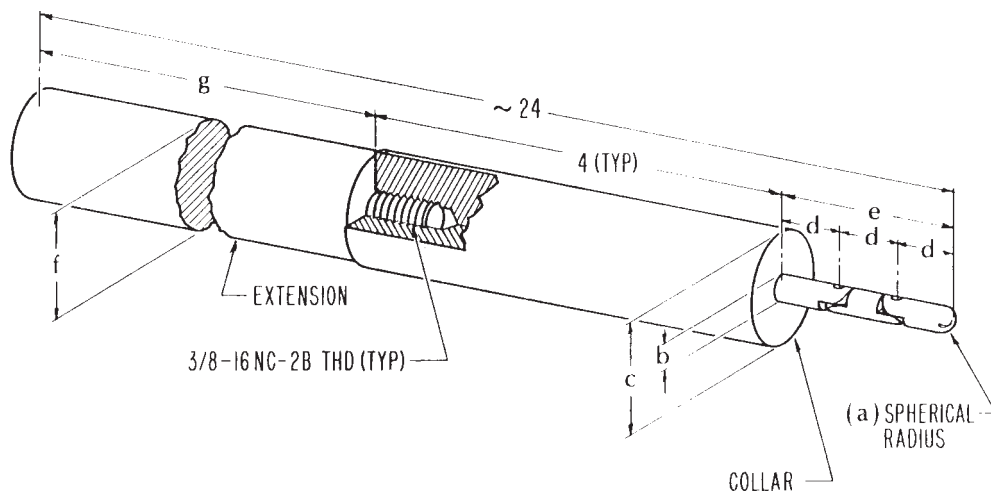

	a	b	c	d	e	f	g
(CHILDREN 0-36 MONTHS INCL)	PROBE A	110	220	1,020	577	1,731	1 18 9/32
(" 37-96 " ")	PROBE B	170	340	1,510	760	2,280	1 1/2 17 25/32

ALL DIMENSIONS IN INCHES

FIG. 1 Accessibility Probes

3.1.9 *elastic*—material that will recover its former size and shape essentially and instantaneously after being elongated at least 10 % at a testing speed of not less than 20 in. (510 mm)/min.

3.1.10 *feathering*—the beveling of an edge (or decrease in thickness moving toward the edge) caused during the shearing or cutting of material.

3.1.11 *flash*—excess material that escapes between the mating parts of a mold assembly.

3.1.12 *folding mechanism*—an assembly of hinged, pivoted, folding, or sliding members that can produce a crushing, scissoring, pinching, or shearing action during operation.

3.1.13 *hazard*—any characteristic of a toy that presents an unreasonable risk of injury or illness during normal use or as a result of reasonably foreseeable abuse.

3.1.15 *hinge-line clearance*—the distance between the stationary portion of a toy and the movable portion along, or adjacent to, a line projected through the axis of rotation, shown as Dimension A in Fig. 4.

3.1.16 *impulsive noise*—one in which the variations in noise level involve maxima at intervals greater than 1 s.

3.1.17 *lap joint*—a joint in which an edge overlaps a parallel surface but is not necessarily attached to it mechanically at all points along the length, as in the examples shown in Fig. 5.

3.1.18 *latex balloon*—any toy or decorative item consisting of a latex bag that is designed to be inflated by air or gas. The term does not include inflatable children's toys that are used in aquatic activities such as rafts, water wings, swim rings, or other similar items.

3.1.19 *marble*—a sphere made of a hard material, such as glass, agate, marble, or plastic, that is used in various children's games, generally as a playing piece or marker. The term "marble" does not include a marble permanently enclosed in a

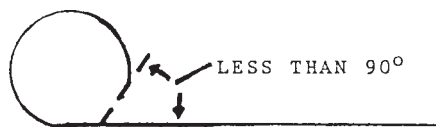
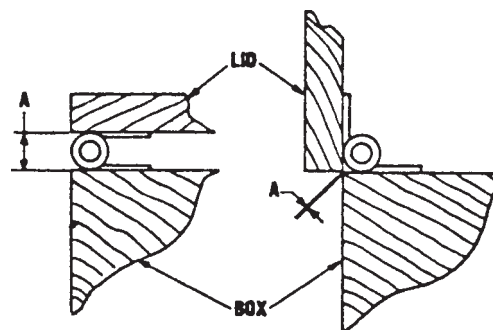

FIG. 2 Curled Edge

3.1.14 *hemmed edge*—an edge in which the portion of the sheet adjacent to the edge is folded back on the sheet itself through an angle of approximately 180°, so that the portion of the sheet adjacent to the edge is approximately parallel to the main sheet, as shown in Fig. 3.



FIG. 3 Hemmed Edge



A = HINGE CLEARANCE AT HINGE LINE

FIG. 4 Changing Clearance at Hinge Line

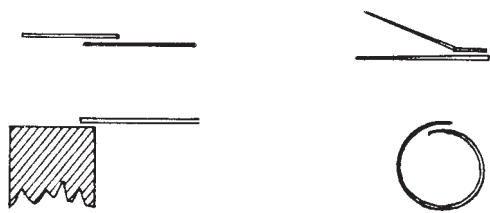

FIG. 5 Typical Lap Joints

toy or game. A marble is permanently enclosed if, when tested in accordance with 16 CFR 1500.53, it is not removed from the toy or game.

3.1.20 *normal use*—play modes that conform to the instructions accompanying the toy, that have been established by tradition or custom, or that are evident from an examination of the toy.

3.1.21 *play cosmetics*—any article intended for play and offered for sale to children through 14 years of age that is intended to be rubbed, sprinkled, or sprayed on, introduced into, or otherwise applied to the human body for cleansing, beautifying, promoting, or enhancing attractiveness or for altering appearance.

3.1.22 *point, hazardous*—an accessible point that presents an unreasonable risk of injury during normal use or reasonably foreseeable abuse. Points on toys intended for children under the age of 8 years are potentially hazardous if they fail the sharp point test described in 16 CFR 1500.48.

3.1.23 *pompom*—lengths or strands of fiber, yarns, or threads clamped or secured and tied in the center, and brushed up to form a spherical shape. Also included are spherical-shaped attachments made of stuffed material.

3.1.24 *principal display panel*—the display panel for a retail package or container, bin, or vending machine that is the side or surface designed to be most prominently displayed, shown, or presented to or examined by prospective purchasers.

3.1.25 *projectile*—an object propelled by means of a discharge mechanism capable of storing and releasing energy under the control of the operator.

3.1.26 *projection, hazardous*—a projection that, because of its material or configuration, or both, may present a puncture hazard if a child should fall onto it. Excluded from this definition are puncture hazards to the eyes or mouth, or both, because of the impossibility of eliminating puncture hazards to those areas of the body by product design.

3.1.27 *protective cap or cover*—a component that is attached to a potentially hazardous edge or projection to reduce the possibility of injury.

3.1.28 *protective tip*—a component that is attached to the impacting end of a projectile to minimize injury if it should impact on the body, and also to prevent damage to the projectile upon striking a target, provide a means of attaching the projectile to the target as in the case of suction cups, or prevent damage to inanimate objects.

3.1.29 *reasonably foreseeable abuse*—conditions to which a child may subject a toy that are not normal use conditions, such as deliberate disassembly, dropping, or using the toy for a purpose for which it was not intended. Simulated use and abuse

tests for toys are given in 16 CFR 1500.50, 1500.51, 1500.52, and 1500.53 (excluding the bite test, Paragraph (c), of each section).

3.1.30 *rigid*—any material having a hardness exceeding 70 Shore A scale durometer, as measured by the latest revision of Test Method D 2240.

3.1.31 *rolled edge*—an edge in which the portion of the sheet adjacent to the edge is bent into an arc and forms an angle between 90 and 120° with the main sheet, as shown in Fig. 6.

3.1.32 *squeeze toy*—a hand-held pliable toy, intended for children under the age of 18 months, usually incorporating a noise-making feature activated by forcing air through an opening when flexed or squeezed, and which recovers to its original shape when released.

3.1.33 *toy*—any object designed, manufactured, or marketed as a plaything for children through the age of 14 years.

4. Safety Requirements

4.1 *Material Quality*—Toys may be made from new or reprocessed materials. If reprocessed materials are used, they must be refined so that the level of hazardous substances conforms to the requirements of 4.3.1.

4.2 *Flammability*—Materials other than textiles (excluding paper) used in toys shall not be flammable, as defined under 16 CFR 1500.3 (c) (6) (vi) under the Federal Hazardous Substances Act (FHSA). For testing purposes, any textile fabrics used in toys should comply with 16 CFR 1610. A test procedure for testing flammability of toys, which is an interpretation of 16 CFR 1500.44, is contained in Annex A5.

4.3 *Toxicology*:

4.3.1 *Hazardous Substances*—Toys or materials used in toys shall conform to the FHSA and to the regulations promulgated under that act. Exemptions to this act for certain types of toys are given in 16 CFR 1500.85. The regulations define limits for substances that are toxic, corrosive, an irritant, sensitizer or pressure generating, and radioactive, flammable, and combustible materials. Testing references for hazardous substance content are given in 8.2. It should be noted that specific states may have hazardous substances regulations that are more restrictive than the Federal regulations.

4.3.2 *Manufacturing and Packaging of Food*—All food products supplied with toys shall be manufactured and packaged in compliance with 21 CFR 110, which is concerned with the sanitation practices for the manufacture, processing, packaging, or holding of human food.

4.3.3 *Indirect Food Additives*—Toy components intended to be used in contact with food, such as toy cooking utensils, shall conform to the applicable requirements of the Food, Drug and Cosmetic Act (FDCA), specifically 21 CFR 170 through 189.

4.3.3.1 *Labeling for Toy Components Used in Contact with Food*—Toys comprising components intended to be used in

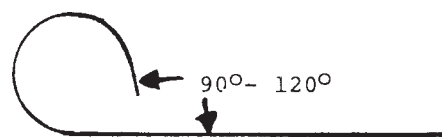

FIG. 6 Rolled Edge

 **F 963 – 96a^{e2}**

contact with food, such as toy cooking utensils and toy tableware, shall bear labeling as described in 5.8.

4.3.3.2 *Ceramicware, Lead, and Cadmium Contamination*—Ceramic toy components intended or likely to hold food, such as a porcelain tea set, shall conform to the applicable requirements of the FDCA, Section 402 (a) (2) (c), and FDA Compliance Policy Guides.

4.3.4 *Cosmetics*—Play cosmetics shall conform to the requirements of the Federal FDCA as codified in 21 CFR. The regulations applicable to cosmetics are stated in 21 CFR 700 through 740. The color additive regulations applicable to cosmetics are found in 21 CFR 73, 74, 81, and 82.

4.3.4.1 In addition, all play cosmetics shall meet all requirements of this specification and the FHSA regulations, notwithstanding the exclusions of 16 CFR 1500.81 and 1500.3 (b) (4) (D) (ii).

4.3.4.2 The requirements from the Food and Drug Administration (FDA) will therefore be additive to those existing for children’s products.

4.3.5 *Paint and Similar Surface-Coating Materials*—Paint and other similar surface-coating materials applied to toys shall comply with the lead content provisions of 16 CFR 1303, issued under the Consumer Product Safety Act (CPSA).

4.3.5.1 The regulation prohibits the use of paints or similar surface-coating materials that contain lead or lead compounds and in which the lead content (calculated as lead metal [Pb]) is in excess of 0.06 % (600 ppm) of the weight of the total nonvolatile content of the paint or the weight of the dried paint film.

4.3.5.2 In addition, surface-coating materials shall not contain compounds of antimony, arsenic, barium, cadmium, chromium, lead, mercury, or selenium, of which the metal content of the soluble material is in excess of the levels by weight of the contained solids (including pigments, film solids, and driers) given in Table 1. The analytical results obtained should be adjusted in accordance with the test method in 8.3.4.3 prior to comparing them to the values in Table 1 to determine conformance. The soluble level shall be determined by dissolving the contained solids (dried film including pigments, film solids, and driers) as specified in 8.3.

4.3.6 *Toy Cosmetics, Liquids, Pastes, Putties, Gels, and Powders*—The purpose of this requirement is to minimize the risk associated with the lack of cleanliness, shelf life, and contamination of toy cosmetics and liquids, gels, and other mobile organic materials used in toys. It sets standards for cleanliness and the ability to withstand extended shelf life or contamination, or both, during use without microbiological degradation.

4.3.6.1 Water used in the manufacturing and filling of toys shall be prepared according to the bacteriological standards for USP Purified Water.

NOTE 1—Caution: The various methods for producing purified water each present different potentials for contaminating the final product. Purified water produced by distillation is sterile, provided that the production equipment is suitable and sterile. On the other hand, ion-exchange columns and reverse osmosis units require special attention in that they afford sites for microorganisms to foul the system and contaminate the effluent. Frequent monitoring may thus be called for, particularly

with the use of these units following periods of shutdown of more than a few hours.

4.3.6.2 The formulations of these products used in toys shall be such that they are not subject to microbial degradation during shelf life or reasonably foreseeable use.

4.3.6.3 The cleanliness of these products used in toys and their ingredients shall be determined in accordance with 8.4.1. Formulations used to prevent microbial degradation shall be evaluated according to 8.4.2.

4.3.7 *Stuffing Materials*—Loose fillers for stuffed toys shall be free of objectionable matter originating from insect, bird, rodent, or other animal infestation and of contaminants, such as splinters and metal chips to the extent possible in good manufacturing practice. The test methods that shall be used to determine objectionable material are in Chapter 16 of *Official Methods of Analysis of the Association of Official Analytical Chemists*.¹⁴ In addition, fiber filling, whether natural or synthetic, should meet the requirements of Title 34, Chapter 47, Section 47.317, “Tolerances of the Commonwealth of Pennsylvania Regulation for Stuffed Toys.”

4.3.8 *DEHP (DOP)*—Pacifiers, rattles, and teethingers shall not intentionally contain DI (2-ethylhexyl) phthalate (also known as dioctyl phthalate). To prevent trace amounts of DEHP (DOP) from affecting analysis, up to 3 % of total solid content will be accepted in the result, when tested in accordance with Practice D 3421.

TABLE 1 Maximum Soluble Migrated Element in ppm (mg/kg) Toy Material

Antimony (Sb)	Arsenic (As)	Barium (Ba)	Cadmium (Cd)	Chromium (Cr)	Lead (Pb)	Mercury (Hg)	Selenium (Se)
60	25	1000	75	60	90	60	500

4.4 *Electrical/Thermal Energy*—Toys operating from nominal 120-V branch circuits shall conform to 16 CFR 1505, issued under the FHSA.

4.5 *Impulsive Noise*—Toys shall not produce impulsive noises with an instantaneous sound pressure level exceeding 138 dB (20 μN/m²) when measured at any position 25 cm from the surface of the toy. The sound levels shall be determined by using the equipment described in 16 CFR 1500.47. When determining sound levels, both the toy and the test equipment shall be at least 1 m from any wall, ceiling, or other large obstruction. As specified herein, the sound levels shall not be exceeded after the toy is tested in accordance with the procedures contained in 8.5-8.10. The sound pressure level for toy caps must not exceed 138 dB when measured as described in 16 CFR 1500.47. The warning statements and notifications to the CPSC, as required by 16 CFR 1500.86 (a) (6), must be observed if the sound pressure level of toy caps exceeds 138 dB when measured using that method.

4.6 *Small Objects*—These requirements are intended to minimize the hazards from ingestion or inhalation to children under 36 months of age created by small objects.

¹⁴ “Extraneous Materials: Isolation,” *Official Methods of Analysis of the Association of Official Analytical Chemists*, 15 ed., Chapter 16, 1990.

4.6.1 Toys that are intended for children under 36 months of age are subject to the requirements of 16 CFR 1501. Criteria for determining which toys are subject to these requirements are provided, in part, in 16 CFR 1500.50 and 1501 and also in Annex A1 of this specification. The requirements of 16 CFR 1501 state, in part, that no toy (including removable, liberated components, or fragments of toys) shall be small enough without being compressed to fit entirely within a cylinder of the specified dimensions as shown in Fig. 7. For the purposes of this specification, fragments of toys include, but are not limited to, pieces of flash, slivers of plastics, pieces of foam, or fine bits or shavings. Pieces of paper, fabric, yarn, fuzz, elastic, and string are excluded from this requirement.

4.6.1.1 The requirements are applicable before and after use and abuse testing in accordance with Section 8 to determine the accessibility of small objects such as small toys or components of toys including eyes, squeakers, or knobs, or pieces that break off or are removed from toys.

4.6.1.2 The following articles are exempt from the requirements: balloons; books and other paper articles; writing materials (crayons, chalk, pencils, and pens); phonograph records; modeling clay and similar products; and fingerpaints, watercolors, and other paint sets. A complete listing of all exempt articles is provided in 16 CFR 1501.3.

4.6.1.3 Toys that are intended to be assembled by an adult and contain potentially hazardous small objects in the unassembled state shall be labeled in accordance with 5.9.

4.6.2 *Mouth-Actuated Toys*—This requirement relates to toys, such as noisemakers, that are intended to be actuated repeatedly by blowing or sucking. Mouth-actuated toys that contain loose objects, such as spheres in a whistle, or inserts, such as reeds in a noisemaker, shall not release an object that will fit within the small parts test cylinder, as shown in Fig. 7,

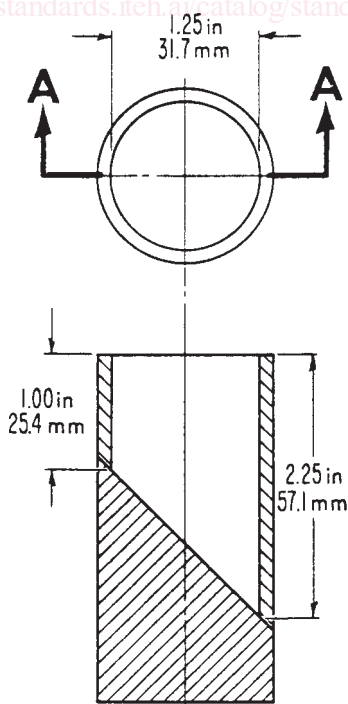

FIG. 7 Small Parts Cylinder

when air is alternately blown and sucked rapidly through the mouthpiece, according to the procedure described in 8.13. The procedure of 8.13 shall also be applied to the outlet if the air outlet is capable of being inserted into or covered by the mouth.

4.6.2.1 Small objects contained in an inflatable toy shall not be liberated during inflation or deflation.

4.6.3 Toys and games that are intended for use by children who are at least three years old (36 months) but less than six years of age (72 months) are subject to the requirements of 16 CFR 1500.19. With the exception of products such as paper punch-out games and similar items, any toy or game that is intended for use by children who are at least three years old (36 months) but less than six years of age (72 months) and includes a small part is subject to the labeling requirements of 5.10.2.

4.7 *Accessible Edges*—Toys shall not have accessible, potentially hazardous sharp edges. Toys that are intended to be assembled by an adult, and may contain unprotected potentially hazardous sharp edges in the unassembled state, shall be labeled in accordance with 5.9.

4.7.1 Potentially hazardous sharp metal and glass edges are defined in 16 CFR 1500.49. Toys intended for use by children under 8 years of age are subject to this requirement before or after use and abuse testing, or both, as specified in 8.5-8.10. An illustration of a sharp edge tester is shown in Fig. 8.

4.7.2 Toys containing potentially hazardous edges that are a necessary part of the function of a toy shall carry cautionary labeling as specified in 5.2 if the toy is intended for use by children from 48 to 96 months. Toys intended for children aged less than 48 months shall not have accessible hazardous functional sharp edges.

4.7.3 *Metal Toys*—Accessible metal edges, including holes and slots, shall be free of hazardous burrs and feathering, or shall be hemmed, rolled, or curled, or shall be covered with a permanently affixed device or finish.

NOTE 2—Regardless of the manner in which edges are finished, they are subject to the sharp edge technical requirements as described in 4.7.1. If a device is used to protect an edge, it shall not become detached after being tested in accordance with the appropriate procedures described in 8.5-8.10.

4.7.4 *Molded Toys*—Accessible edges, corners, or mold parting areas of molded toys should be free of hazardous edges produced by burrs and flash or so protected that hazardous edges are not exposed.

4.7.5 *Exposed Bolts or Threaded Rods*—If the ends of bolts or threaded rods are accessible, the thread shall be free of exposed, hazardous sharp edges and burrs, or the ends shall be covered by smooth finish caps so that hazardous sharp edges and burrs will not be exposed. Any caps that are used shall be subjected to the compression test noted in 8.10, regardless of whether the cap is accessible to flat-surface contact during the appropriate impact test(s) described in 8.7. Protective caps shall also be subjected to the tension test in 8.9 and the torque test in 8.8.

4.8 *Accessible Points*—Toys shall not have accessible, potentially hazardous sharp points that may occur because of the following: configuration of the toy; assembly devices such as wires, pins, nails, and staples that are fastened poorly; poorly

ASTM F 963 – 96a^{e2}

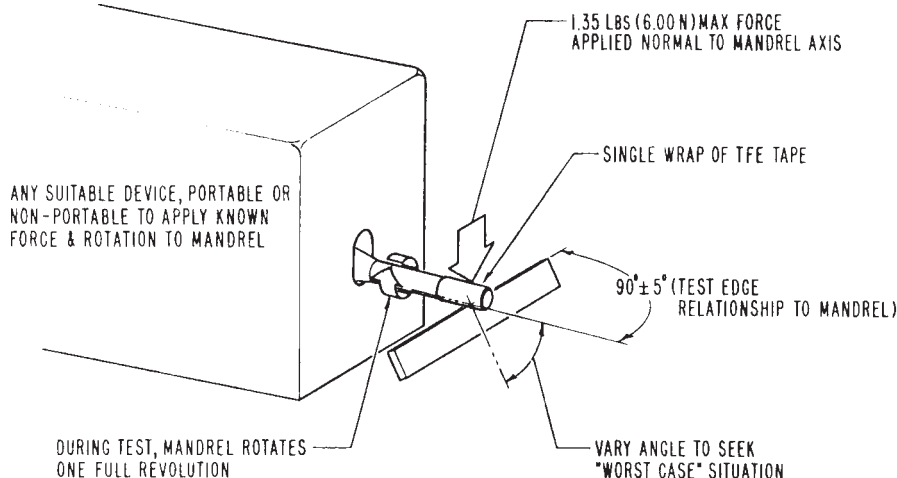

FIG. 8 Principle of Sharp Edge Test

sheared sheet metal; burrs on screws; and splintered wood. Toys that are intended to be assembled by an adult and may contain potentially hazardous sharp points in the unassembled state shall be labeled in accordance with 5.9.

4.8.1 Potentially hazardous sharp points are defined by 16 CFR 1500.48. Toys intended for use by children under 8 years of age are subject to this requirement before or after use and abuse testing, or both, as specified in 8.5-8.10. An illustration of a sharp-point tester is shown in Fig. 9.

4.8.2 Toys in which an accessible, potentially hazardous sharp point is a necessary function of the toy, such as a needle in a sewing kit, shall carry cautionary labeling as specified in 5.2, if the toy is intended for children from 48 to 96 months old. Toys intended for children less than 48 months old shall not have accessible hazardous functional points.

4.8.3 *Wood*—The accessible surfaces and edges of wood used in toys shall be free of splinters, both before and after being tested in accordance with the appropriate procedures described in 8.5-8.10.

4.9 *Projections*—This requirement relates to potentially hazardous projections in toys intended for use by children under 8 years of age. This requirement is intended to minimize possible puncture hazards to the skin that might be caused should a child fall on a rigid projection, such as unprotected ends of axles, actuating levers, and decorative features. Due to the extremely sensitive nature of the eyes and interior of the mouth, this requirement will not, nor is it intended to, provide protection to those areas of the body. If a projection appears to present a potential skin puncture hazard, the projection shall be protected by suitable means, such as by turning back the end of

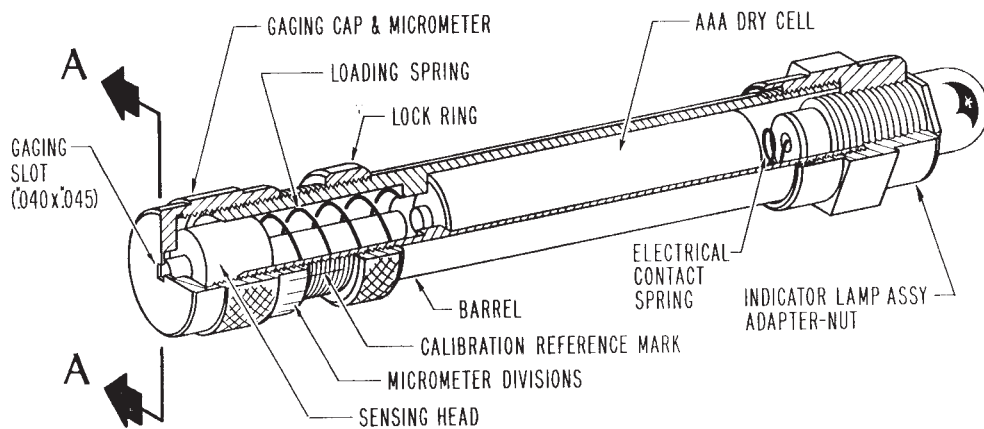
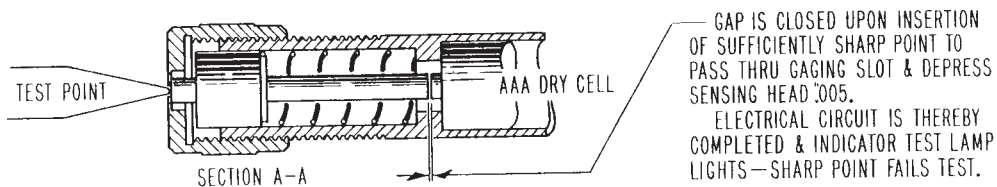

FIG. 9 Sharp Point Tester

a wire or by affixing a smoothly finished protective cap or cover, which effectively increases the surface area for potential contact with the skin. The toy shall meet this requirement both before and after testing in accordance with 8.5-8.10.

4.10 *Nails and Fasteners*—Nails and fasteners shall not present a point, edge, ingestion, or projection hazard. Points of nails or fasteners shall not protrude so as to be accessible. Additional requirements for nails and fasteners used as axles are given in 4.14.

4.11 *Wires or Rods*—Wires or rods used in the interior of toys shall have their ends finished to avoid potentially hazardous points and burrs, shall be turned back, or shall be covered with smoothly finished protective caps or covers, if they can become accessible after use or reasonably foreseeable abuse. Metal wires or other metal materials used for stiffening or for retention of form in toys shall not fracture to produce a hazardous point, edge, or projection hazard when tested in accordance with 8.12, if the component can be bent through a 60° arc by the applicable maximum force. When applied perpendicularly to the major axis of the component at a point 2 ± 0.05 in. (50 ± 1.3 mm) from the intersection of the component with the main body of the toy or at the end of the component if the component is less than 2 in. (50 mm) long, the maximum force shall be as follows (within a tolerance of ± 0.5 lb (± 0.02 kg)):

10 lbf (45 N)	toys intended for use by children 18 months of age or less
15 lbf (67 N)	toys intended for use by children over 18 but not over 96 months of age

4.12 *Packaging Film*—This requirement is intended to minimize the possibility of asphyxiation hazards that might be caused by thin packaging films. Flexible plastic film bags and flexible plastic sheets used as packaging materials for shelf packages or used with toys shall be at least 0.00150 in. (0.03810 mm) in nominal thickness, but the actual thickness shall never be less than 0.00125 in. (0.03175 mm). The thickness shall be determined in accordance with Test Method C of Test Methods D 374. This requirement does not apply to the following:

4.12.1 Bags that have an opening perimeter less than 14 in. (360 mm) after the perimeter has been stretched to its fullest extent.

4.12.2 Bags that have an opening perimeter of 14 in. (360 mm) or greater after the perimeter has been stretched to its fullest extent, in which the combined length and fully extended opening perimeter are less than 23 in. (584 mm).

4.12.3 Shrink film of less than 0.00150 in. (0.03810 mm) nominal thickness that is in the form of an overwrap that would normally be destroyed when the package is opened by a consumer.

4.13 *Cords and Elastics*—These requirements are intended to minimize entanglement and strangulation hazards that might be caused by accessible cords and elastics. The requirements are applicable before and after use and abuse testing in accordance with 8.5-8.10.

4.13.1 *Cords and Elastics in Toys*—Cords or elastics included with or attached to toys intended for children less than 18 months of age (excluding pull toys, see 4.13.2) shall be less than 12 in. (305-mm) long when measured to the maximum

length in a free state and under a load of 5 lb (2.25 kg). If cords/elastics or multiple cords/elastics can tangle or form a loop, or both, in connection with any part of the toy, including beads or other attachments on the ends of cords/elastics, the perimeter of the loop shall be less than 14 in. (356 mm) under a load of 5 lb (2.25 kg).

4.13.1.1 *Self Retracting Pull Cords*—Accessible cords used in cord-activated mechanisms in toys intended for use by children under 18 months of age, except monofilament-type cords $\frac{1}{16}$ in. (2 mm) or less in diameter, shall not retract more than $\frac{1}{4}$ in. (6 mm) when a weight of 2 lb (0.9 kg) is attached to the fully extended cord with the cord held vertical and the toy held firmly in the most favorable position for retraction. Monofilament cords, $\frac{1}{16}$ in. (2 mm) or less in diameter, shall not retract under a load of 1 lb (0.45 kg) when tested in the manner described above.

4.13.2 *Pull Toys*—Cords and elastics greater than 12 in. (300 mm) long for pull toys intended for children under 36 months of age shall not be provided with beads or other attachments that could tangle to form a loop.

4.13.3 *Strings and Lines for Flying Devices*—Kite strings and hand-held lines over 6 ft (1.8 m) long, attached to flying devices intended for use as playthings, shall have an electric resistivity of more than $10^8 \Omega \cdot \text{cm}$ when tested at a relative humidity of not less than 45 % and a temperature of not greater than 75°F (24°C), when measured by a high-voltage, resistance breakdown meter.

4.14 *Wheels, Tires, and Axles*—These requirements are intended to eliminate the possibility of ingestion hazards (as described in 4.6) that might be caused by small wheels or tires that separate during normal use or reasonably foreseeable abuse, as well as laceration or puncture hazards from projecting axles, either on the toy or on wheel assemblies that may be removed from the toy during abuse. The requirements shall apply to transportation wheels on both preassembled and knocked-down toys intended for children aged 96 months or less, except for ingestion hazards from small wheels and axles, which apply to toys intended for children under 36 months of age, as covered in 4.6. In the case of knocked-down toys, the toy shall be tested in the form that it would be assembled by the purchaser, using simple household tools or special tools provided by the manufacturer, if any, or both. After being subjected to the use and abuse tests of 8.5-8.11, wheels, tires, or axles shall not present a laceration, puncture, or ingestion hazard as defined in 3.1.19, 3.1.21, and 4.6.1, respectively.

4.15 *Folding Mechanisms and Hinges*—These requirements are intended to eliminate possible crushing, laceration, or pinching hazards that might occur in folding mechanisms and hinges used in toys capable of supporting the weight of a child. Examples are the sudden collapse or unexpected motion of a folding mechanism or hinge that produces a scissor action; and the changing clearances at the hinge line between two hinged portions, such that the gap will admit fingers at one position of the hinge but not at all positions. These requirements do not relate to the recognized and familiar hazards associated with the changing clearances around the edges of doors or pivoted or hinged sections in toy truck bodies, toy earth moving machinery, and similar toys not capable of supporting the

 **F 963 – 96a^{e2}**

weight of a child. Toys shall meet the requirements specified in 4.15.1 and 4.15.2 after they are tested in accordance with 8.5-8.10. Requirements for toy chests are contained in 4.26.

4.15.1 *Folding Mechanisms*—Toy furniture and other toys in which a folding mechanism, arm, or bracing is intended to support a child or comparable weight for normal use or reasonable foreseeable abuse shall have a safety stop or locking device to prevent unexpected or sudden movement or collapse of the article, or have adequate clearance to provide protection for the fingers, hands, and toes from crushing or laceration in the event of sudden movement or collapse of the article.

4.15.2 *Hinge-Line Clearance*—Toys having a gap or clearance along the hinge line between a stationary portion and a moveable portion that weighs more than ½ lb (0.2 kg) shall be so constructed that, if the accessible gap at the hinge line will admit a 3/16-in. (5-mm) diameter rod, it will also admit a ½-in. (13-mm) diameter rod at all positions of the hinge.

4.16 *Holes, Clearance, and Accessibility of Mechanisms*—These requirements are intended to eliminate possible hazards that may be caused by changing clearances. Toys shall meet these requirements after they are tested in accordance with 8.5-8.10. The different pinch clearance requirements listed in 4.16.1-4.16.6 reflect the different modes of entrapment or pinching that may be encountered.

4.16.1 *Accessible Clearances for Moveable Segments*—This requirement concerns clearances between movable segments on toys intended for children under 96 months only, where the potential for pinching or crushing fingers or other appendages exists. It includes, but is not limited to, wheels and rigid-wheel wells, fenders, or the radial clearance between the wheels and chassis of ride-on toys, or the driven wheels and other parts of toys powered by electrical, spring, or inertial energy. If such accessible clearances admit a 3/16-in. (5-mm) diameter rod, they shall also admit a ½-in. (13-mm) diameter rod in order to prevent the trapping of fingers.

4.16.2 *Circular Holes in Rigid Materials*—This requirement is intended to prevent finger entrapment (which may cut off blood circulation) in accessible holes in sheet metal and other rigid material in toys intended for children aged 60 months or less. (Noncircular holes are believed to present no significant hazard of cutting off blood circulation in entrapped fingers.) If an accessible, circular hole in any rigid material less than 0.062 in. (1.58 mm) in thickness can admit a ¼-in. (6-mm) diameter rod to a depth of 3/8 in. (10 mm) or greater, it shall also admit a ½-in. (13-mm) diameter rod.

4.16.3 *Chains and Belts*—These requirements are to prevent finger crushing through entrapment between links of supporting chains or between chains and sprockets or pulleys and belts.

4.16.3.1 *Supporting Chains*—Chains in toys that support the weight of a child, such as hanging seats or similar indoor devices, intended for children 36 months or less in age, shall be shielded if the chain is accessible and if a 0.19-in. (5-mm)

diameter rod can be inserted between two links, as in Fig. 10, with the chain in slack configuration.

4.16.3.2 *Chains or Belts for Ride-On Toys*—Power transmission chains and belts in ride-on toys shall be shielded.

4.16.4 *Inaccessibility of Mechanisms*—Clockwork, battery-operated, inertial, or other power-driven mechanisms in toys intended for children aged 60 months or less shall not have any accessible part of the mechanism present a pinch or laceration hazard. (For circular holes, also see the requirement under 4.16.2.)

4.16.5 *Winding Keys*—This requirement is to prevent the pinching or laceration of fingers by entrapment between the key and body of the toy. It applies to toys intended for children under 36 months of age that use winding keys that rotate as the mechanism unwinds. This requirement applies to keys with flat plates attached to the stem and that protrude from a rigid surface; the requirement does not apply to those circular knobs to which the torque is applied. If the clearance between the flukes of the key and body of the toy will admit a 0.25-in. (6-mm) diameter rod, it shall also admit a 0.5-in. (13-mm) diameter rod at all positions of the key. For keys covered by this requirement, there shall be no opening in the flukes of the key that can admit a 0.19-in. (5-mm) diameter rod.

4.16.6 *Coil Springs*—These requirements are intended to prevent the pinching or crushing of fingers or toes by toys containing springs. Coil springs (either compression or extension) that form part of a component that carries the weight of a child shall be shielded so as to prevent access during use or reasonably foreseeable abuse unless either of the following occurs:

4.16.6.1 A 0.12-in. (3-mm) diameter rod cannot be inserted freely; or

4.16.6.2 A 0.25-in. (6-mm) diameter rod can be inserted freely between the adjacent coils at all points in the action cycle when the spring is subjected first to a weight of 3 lb (1.4 kg) and then to a weight of 70 lb (32 kg).

4.17 *Stability and Over-Load Requirements:*

4.17.1 *Stability of Ride-On Toys and Seats*—These requirements are intended to minimize unexpected hazards that could be caused by a toy that can tip easily. They take into account the use of the child's legs as stabilizing means and recognize that a child learns instinctively to compensate for inclined positions. The requirements listed in 4.17.2 and 4.17.3 shall apply to the following classes of toys intended for use by children aged 60 months or less: ride-on toys, with three or more load bearing wheels, such as wagons; ride-on, action-type toys such as hobby horses; and stationary toys with seats, such as play furniture. Ride-on toys of spherical, cylindrical, or other shape that do not normally have a stable base are not covered by these requirements. The toy shall conform to these requirements after it is tested in accordance with 8.5-8.10.

4.17.2 *Sideways Stability Requirements*—These requirements recognize two types of possible stability hazards: those

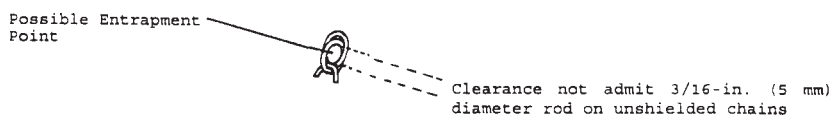

FIG. 10 Clearance for Chain Links

associated with ride-on toys or seats in which the feet can provide stabilization, and those situations in which the feet are restricted by an enclosing structure.

4.17.2.1 *Sideways Stability, Feet Available for Stabilization*—There shall be no sideways stability test for those ride-on toys or seats in which the height of the seat from the ground is one third or less than one third of the height indicated in Table 2 at the lowest age of the age range for which the ride-on toy or seat is intended, and in which the legs of the child are unrestricted in their sideways motion and thus are available for stabilization. (The values given in Table 2 represent the lower of the following two numbers: (1) the fifth percentile group of boys at each age from 1 up to and including 5 years and (2) the fifth percentile group of girls at each age from 1 up to and including 5 years.) For those ride-on toys, or seats in which the height of the seat from the ground is greater than one third of the height indicated in Table 2 at the lowest age of the age range for which the ride-on toy or seat is intended, and in which the legs of the child are unrestricted in their sideways motion and thus are available for stabilization, the toy shall not tip when tested in accordance with 8.16.

4.17.2.2 *Sideways Stability, Feet Unavailable for Stabilization*—If the sideways motion of the feet or legs, or both, is restricted, such as by the enclosed sides of a toy automobile, the ride-on toy or seat shall not tip when tested as specified in 8.16, except that the surface shall be inclined 15° to the horizontal.

4.17.3 *Fore and Aft Stability*—This requirement relates to the stability of the ride-on toy in the front and back direction with respect to the rider, where the rider cannot easily use the legs for stabilization. All ride-on toys falling within the scope of 4.17 shall not tip forward or backward when the toy, which shall be loaded with a simulated child’s weight, is tested both facing down and up the slope using the test method of 8.16, except that the surface shall be inclined 15° to the horizontal. The stability of ride-on toys is to be tested not only with the steering wheels in a forward position, but also at an angle of 45° to the left and to the right of the forward position.

4.17.4 *Stability of Stationary Floor Toys*—This requirement is intended to minimize hazards that might be caused by a toy that tips when a door, drawer, or other movable portion is extended to its fullest travel. Stationary floor toys of greater than 30 in. (760 mm) in height and weighing more than 10 lb (4.5 kg) shall not tip when placed on a 10° incline with all movable portions extended to their fullest travel and facing in the direction of the downslope side. The toy shall conform to this requirement after it is tested in accordance with 8.5-8.10.

4.17.5 *Overload Requirements for Ride-On Toys and Seats*—This requirement is intended to minimize unexpected

hazards that could be caused by a toy that is not capable of withstanding an overload. All ride-on toys, toys intended for use as seats, or toys designed to support all or part of the weight of the child shall support a load applied to the seat, or to other such intended load-bearing components, without collapsing to produce a hazardous condition. (Examples of hazardous conditions if collapse occurs would include the following: exposure of hazardous edges or points, projections, crushing or pinching hazards, and power-driven mechanisms.) This load shall be three times the weight indicated in Table 3 at the highest age of the age range for which the toy is intended. The toy shall conform to this requirement after being tested in accordance with 8.5-8.10. The test for overload requirements shall be conducted so that it will be consistent with the advertised weight capacity if that figure is higher than the minimum weight capacity in accordance with Table 3.

4.18 *Confined Spaces*—The purpose of these requirements is to minimize the possible entrapment of children in toys that form enclosures, such as toy refrigerators, and to prevent possible suffocation in head-enclosing toys such as space helmets. Toys shall meet the requirements listed in 4.18.1-4.18.3 after the toys are tested in accordance with 8.5-8.10. See 4.26 for requirements for toy chests.

4.18.1 *Ventilation*—Any toy having a door or lid, which encloses a continuous volume greater than 1.1 ft³ (0.03 m³), and in which all internal dimensions are 6 in. (150 mm) or more, shall provide an unobstructed ventilation area of greater than a total of 2 in.²(1300 mm²) over two or more separate openings situated at least 6 in. (150 mm) apart when the toy is placed on the floor in any position and adjacent to two vertical plane surfaces meeting at a 90° angle, so as to simulate the corner of a room. The ventilation area shall not be required if a permanent partition or bars (two or more), which effectively limit the continuous space by making the largest internal dimension less than 6 in. (150 mm), are used to subdivide a continuous space.

4.18.2 *Closures*—Closures (such as lids, covers, and doors) to enclosures falling within the scope of 4.18.1 shall not be fitted with automatic locking devices. Closures shall be of a type that can be opened with a force of 10 lbf (45 N) or less when treated as follows:

TABLE 3 Weight of 95th Percentile Children (Values Given for Boys or Girls, Whichever is Higher)

Age, years	Weight, lb (kg)
1	28 (12.6)
2	29 (13.2)
3	42 (18.9)
4	43 (19.7)
5	50 (22.6)
6	59 (26.6)
7	69 (31.2)
8	81 (37.0)
9	89 (40.4)
10	105 (47.9)
11	121 (55.0)
12	120 (54.7)
13	140 (63.6)
14	153 (69.6)

TABLE 2 Height of Fifth Percentile Children (Values Given for Boys or Girls, Whichever is Lower)

Age, years	Height, in. (cm)
1	27 (69.8)
2	29 (74.4)
3	33 (85.1)
4	37 (93.8)
5	40 (100.5)