



Designation: D7466/D7466M – 10 (Reapproved 2015)^{ε1}

Standard Test Method for Measuring Asperity Height of Textured Geomembranes¹

This standard is issued under the fixed designation D7466/D7466M; the number immediately following the designation indicates the year of original adoption or, in the case of revision, the year of last revision. A number in parentheses indicates the year of last reapproval. A superscript epsilon (ϵ) indicates an editorial change since the last revision or reapproval.

^{ε1} NOTE—Designation was changed to dual and units information was corrected editorially in June 2015.

1. Scope

1.1 This test method covers a procedure to measure the asperity height of textured geomembranes.

1.2 This test method does not provide for measurement of the spacing between the asperities nor of the complete profile of the textured surface.

1.3 The values stated in either SI units or inch-pound units are to be regarded separately as standard. The values stated in each system may not be exact equivalents; therefore, each system shall be used independently of the other. Combining values from the two systems may result in non-conformance with the standard.

1.4 *This standard does not purport to address all of the safety concerns, if any, associated with its use. It is the responsibility of the user of this standard to establish appropriate safety and health practices and determine the applicability of regulatory limitations prior to use.*

2. Referenced Documents

- 2.1 *ASTM Standards*:²
- D4439 Terminology for Geosynthetics
 - D5994/D5994M Test Method for Measuring Core Thickness of Textured Geomembranes
 - E177 Practice for Use of the Terms Precision and Bias in ASTM Test Methods
 - E691 Practice for Conducting an Interlaboratory Study to Determine the Precision of a Test Method
 - E2554 Practice for Estimating and Monitoring the Uncertainty of Test Results of a Test Method Using Control Chart Techniques

¹ This test method is under the jurisdiction of ASTM Committee D35 on Geosynthetics and is the direct responsibility of Subcommittee D35.10 on Geomembranes.

Current edition approved May 1, 2015. Published June 2015. Originally approved in 2008. Last previous edition approved in 2010 as D7466-10. DOI: 10.1520/D7466_D7466M-10R15E01.

² For referenced ASTM standards, visit the ASTM website, www.astm.org, or contact ASTM Customer Service at service@astm.org. For *Annual Book of ASTM Standards* volume information, refer to the standard's Document Summary page on the ASTM website.

3. Terminology

3.1 For definitions of other terms used in this test method, refer to Terminology D4439.

3.2 Definitions:

3.2.1 *asperity, n*—the individual projections of polyethylene that extend above the core surface of a textured geomembrane resulting in the textured surface profile.

3.2.2 *core thickness, n*—the average thickness of a textured geomembrane as measured using Test Method D5994/D5994M.

3.2.3 *geomembrane, n*—an essentially impermeable geosynthetic composed of one or more synthetic sheets. D4439

3.2.4 *setting block, n*—the component part of a depth gauge that rests on top of the asperities.

3.2.5 *thickness, n*—the perpendicular distance between one surface and its opposite.

3.2.6 *thickness gauge contact point, n*—the tip of a thickness gauge which contacts the base sheet of the geomembrane surface.

4. Summary of Test Method

4.1 The asperity height of a textured geomembrane is measured with a depth gauge, the setting block of which rests on the top of the asperities while the contact point extends to the sheet's core surface.

4.2 The asperity height of a textured geomembrane is calculated as the average value of ten (10) individual measurements taken across the roll width of the sample under investigation.

5. Significance and Use

5.1 The asperity height is an index property used to quantify one of the physical attributes related to the surface roughness of textured geomembranes.

5.2 This test method is applicable to all currently available textured geomembranes that are deployed as manufactured geomembrane sheets.

6. Apparatus

6.1 *Depth Gauge*—The depth gauge shall consist of three components that conform the requirements of this section; a dial indicator, a setting block and a contact point with extension.

6.1.1 *Dial Indicator*—Capable of measuring to depth of at least 2.5 mm [0.10 in.] with an accuracy of ± 0.025 mm [0.001 in.].

6.1.2 *Setting Block*—The setting block shall have a base dimension of 50 mm to 63.5 mm long by 20 mm to 12.7 mm wide [2.0 in. to 2.5 in. long by 0.75 in. to 0.50 in. wide] and a height of 15 mm [0.60 in.].

6.1.3 *Contact Point with Extension*—The contact point is 1.3 mm [0.051 in.] in diameter with the tip tapered to a point. An extension of approximately 17 mm [0.66 in.] is required to achieve the necessary travel beyond the base surface of the setting block. The contact point should protrude at least 10 mm below the setting block when not in use in order to ensure that a competent “zero” setting is achieved. See Figs. 1-3.

6.1.4 The mass of the depth gauge fully assembled with the dial indicator, setting block, contact point with extension should not exceed 300 g.

7. Sampling

7.1 *Sample*—For the sample, take a full width sample at least 75-mm [3-in.] wide. Exclude the inner and outer wraps of the roll or any material not representative of the sample. Either the entire strip may be tested or individual test specimens may be taken from this sample, with a minimum diameter of 75 mm [3 in.], spaced such that a total of ten (10) asperity height determinations will be made approximately evenly across the sample.

7.2 *Sample Labeling*—For textured geomembrane samples that are textured on both sides, identify one surface as “Side A” and the other as “Side B.” Side A should correspond to the outside surface of the product when on the parent roll, and Side B the inside surface whenever this relationship is known.

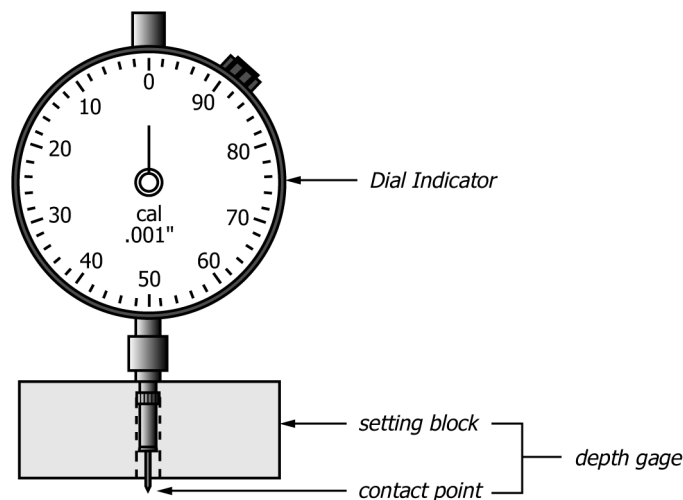

FIG. 1 Asperity Height Test Gauge

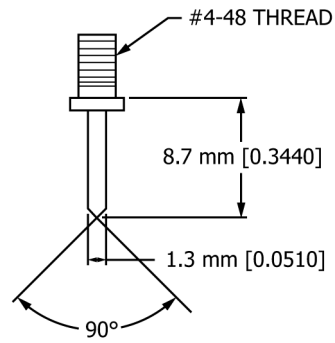

FIG. 2 Contact Point

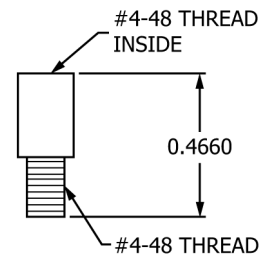

FIG. 3 Contact Extension

8. Conditioning and Testing

8.1 Bring the specimens to temperature equilibrium at $21 \pm 2^\circ\text{C}$ [$70 \pm 4^\circ\text{F}$] and at a relative humidity of $60 \pm 10\%$.

9. Procedure

9.1 Test the conditioned specimens in the standard laboratory atmosphere specified in 8.1.

9.2 Place the depth gauge on a flat, rigid supporting surface to zero the contact point with the bottom of the setting block.

9.3 Place the geomembrane specimen being tested on a flat, rigid, supporting surface being vigilant to keep the specimen flat for the measurements. For two side textured geomembranes, measure the asperity height of Side A first.

9.4 Place the depth gauge on the surface of the textured geomembrane specimen, with the long axis of the setting block perpendicular to the machine direction of the roll. Do not to apply downward hand pressure on the gauge as this would compress the asperities under the setting block. Allow the contact point to come into contact with the “low spots” or “valleys,” in between the asperities, or into the indentations, of the textured surface(s). Move the depth gauge slightly on the test specimen to obtain the local maximum reading. Repeat the above within a search radius of approximately 12 mm [0.5 in.] so that a total of three observations are obtained. Record the highest value of the three observations to the nearest 0.025 mm or 0.001 in. as the asperity height determination.

NOTE 1—Be vigilant not to drag the extended contact point while moving the depth gauge laterally across the sample between determinations as this can result in damage to the contact point.

NOTE 2—The parent standard for this procedure, GRI GM-12, originally specified that the local highest asperity measurement is taken for each asperity height determination. This is consistent with procedure for determining the thickness of a textured geomembrane in accordance with