



Designation: B80 – 15

# Standard Specification for Magnesium-Alloy Sand Castings<sup>1</sup>

This standard is issued under the fixed designation B80; the number immediately following the designation indicates the year of original adoption or, in the case of revision, the year of last revision. A number in parentheses indicates the year of last reappraisal. A superscript epsilon ( $\epsilon$ ) indicates an editorial change since the last revision or reappraisal.

*This standard has been approved for use by agencies of the U.S. Department of Defense.*

## 1. Scope

1.1 This specification covers magnesium-alloy sand castings designated as shown in [Table 1](#).

1.2 The values stated in inch-pound units are to be regarded as the standard. The SI values in parentheses are provided for information only.

1.3 *This standard does not purport to address all of the safety concerns, if any, associated with its use. It is the responsibility of the user of this standard to establish appropriate safety and health practices and determine the applicability of regulatory limitations prior to use.*

## 2. Referenced Documents

2.1 The following documents of the issue in effect on date of order acceptance form a part of this specification to the extent referenced herein:

2.2 *ASTM Standards:*<sup>2</sup>

[B93/B93M Specification for Magnesium Alloys in Ingot Form for Sand Castings, Permanent Mold Castings, and Die Castings](#)

[B296 Practice for Temper Designations of Magnesium Alloys, Cast and Wrought](#)

[B557 Test Methods for Tension Testing Wrought and Cast Aluminum- and Magnesium-Alloy Products](#)

[B660 Practices for Packaging/Packing of Aluminum and Magnesium Products](#)

[B661 Practice for Heat Treatment of Magnesium Alloys](#)

[B951 Practice for Codification of Unalloyed Magnesium and Magnesium-Alloys, Cast and Wrought](#)

[E29 Practice for Using Significant Digits in Test Data to Determine Conformance with Specifications](#)

[E35 Test Methods for Chemical Analysis of Magnesium and Magnesium Alloys \(Withdrawn 2008\)](#)<sup>3</sup>

[E88 Practice for Sampling Nonferrous Metals and Alloys in Cast Form for Determination of Chemical Composition](#)

[E94 Guide for Radiographic Examination](#)

[E155 Reference Radiographs for Inspection of Aluminum and Magnesium Castings](#)

[E165 Practice for Liquid Penetrant Examination for General Industry](#)

[E527 Practice for Numbering Metals and Alloys in the Unified Numbering System \(UNS\)](#)

[E716 Practices for Sampling and Sample Preparation of Aluminum and Aluminum Alloys for Determination of Chemical Composition by Spectrochemical Analysis](#)

2.3 *Federal Standards:*<sup>4</sup>

[Fed. Std. No. 123 Marking for Shipment \(Civil Agencies\)](#)

[Fed. Std. No. 184 Identification Marking of Aluminum, Magnesium and Titanium](#)

2.4 *Military Standards:*<sup>4</sup>

[MIL-STD-129 Marking for Shipment and Storage \(Military Agencies\)](#)

[MIL-STD-276 Impregnation of Porous Non-ferrous Metal Castings](#)

[MIL-I-13857 Impregnation of Metal Castings](#)

[MIL-M-46062 Magnesium Alloy Castings, High Strength](#)

[MIL-M-6857 Heat Treatment of Magnesium Alloy Castings](#)

2.5 *ANSI Standard:*<sup>5</sup>

[ANSI Z1.4 Sampling Procedures and Tables for Inspection by Attributes](#)

## 3. Terminology

3.1 *Definitions:*

3.1.1 *casting lot, n*—unless otherwise agreed, shall consist of not more than 1000 lb of cleaned castings from the same

<sup>1</sup> This specification is under the jurisdiction of ASTM Committee B07 on Light Metals and Alloys and is the direct responsibility of Subcommittee B07.04 on Magnesium Alloy Cast and Wrought Products.

Current edition approved May 1, 2015. Published June 2015. Originally approved in 1930. Last previous edition approved in 2009 as B80–09. DOI: 10.1520/B0080-15.

<sup>2</sup> For referenced ASTM standards, visit the ASTM website, [www.astm.org](http://www.astm.org), or contact ASTM Customer Service at [service@astm.org](mailto:service@astm.org). For *Annual Book of ASTM Standards* volume information, refer to the standard's Document Summary page on the ASTM website.

<sup>3</sup> The last approved version of this historical standard is referenced on [www.astm.org](http://www.astm.org).

<sup>4</sup> Available from Standardization Documents Order Desk, DODSSP, Bldg. 4, Section D, 700 Robbins Ave., Philadelphia, PA 19111-5098, <http://www.dodssp.daps.mil>.

<sup>5</sup> Available from American National Standards Institute (ANSI), 25 W. 43rd St., 4th Floor, New York, NY 10036, <http://www.ansi.org>.

**TABLE 1 Chemical Requirements<sup>A</sup>**

NOTE 1—Analysis shall regularly be made only for the elements specifically mentioned in this table. If, however, the presence of other elements is suspected or indicated in amounts greater than the specified limits, further analysis shall be made to determine that these elements are not present in excess of the specified limits.

NOTE 2—The following applies to all specified limits in this table: For purposes of acceptance and rejection, an observed value or a calculated value obtained from analysis shall be rounded to the nearest unit in the last right-hand place of figures used in expressing the specified limit.

Chemical Composition Limits for Registered Magnesium Alloys																			
Alloy Number <sup>B</sup>	ASTM	UNS	Magne- sium	Alu- minum	Copper	Gado- linium	Iron	Lithium	Man- gane- sium	Neo- dymium	Nickel	Rare Earths	Silicon	Silver	Yttrium	Zinc	Zirconium	Others (Metallic Impurities) Each	Total <sup>C</sup> Impu- rities
AM100A	M10100	remainder	9.3–10.7	0.10	...	...	...	...	0.10–0.35	...	0.01	...	0.30	...	...	0.30	...	...	0.30
AZ63A	M11630	remainder	5.3–6.7	0.25	...	...	...	...	0.15–0.35	...	0.01	...	0.30	...	...	2.5–3.5	...	...	0.30
AZ81A	M11810	remainder	7.0–8.1	0.10	...	...	...	...	0.13–0.35	...	0.01	...	0.30	...	...	0.40–1.0	...	...	0.30
AZ91C	M11914	remainder	8.1–9.3	0.10	...	...	...	...	0.13–0.35	...	0.01	...	0.30	...	...	0.40–1.0	...	...	0.30
AZ91E	M11919	remainder	8.1–9.3	0.015	...	...	...	...	0.17–0.35	...	0.0010	...	0.20	...	...	0.40–1.0	...	0.01	0.30
AZ92A	M11920	remainder	8.3–9.7	0.25	...	...	...	...	0.10–0.35	...	0.01	...	0.30	...	...	1.6–2.4	...	...	0.30
EQ21A	M18330	remainder	...	0.05–0.10	...	...	...	...	...	...	0.01	1.5–3.0 <sup>F</sup>	...	1.3–1.7	...	...	0.40–1.0	...	0.30
EV31A <sup>F</sup>	M12310	remainder	...	0.01	1.0–1.7	0.010	...	...	...	2.6–3.1	0.0020	0.4 <sup>G</sup>	...	0.05	...	0.20–0.50	0.40–1.0	0.01	...
EZ33A	M12330	remainder	...	0.10	...	...	...	...	...	...	0.01	2.5–4.0 <sup>H</sup>	...	...	...	2.0–3.1	0.50–1.0	...	0.30
K1A	M18010	remainder	...	...	...	...	...	...	...	...	...	...	...	...	...	...	0.40–1.0	...	0.30
QE22A	M18220	remainder	...	0.10	...	...	...	...	...	...	0.01	1.8–2.5 <sup>F</sup>	...	2.0–3.0	...	...	0.40–1.0	...	0.30
WE43A	M18430	remainder	...	0.03	...	...	0.01	0.2	0.15	2.0–2.5	0.005	1.9 <sup>I</sup>	0.01	...	3.7–4.3	0.20	0.40–1.0	0.2	...
WE43B	M18432	remainder	...	0.02	...	...	0.010	0.2	0.03	2.0–2.5	0.005	1.9 <sup>I</sup>	...	J	3.7–4.3	J	0.40–1.0	0.01	...
WE54A	M18410	remainder	...	0.03	...	...	...	0.2	0.03	1.5–2.0	0.005	2.0 <sup>I</sup>	0.01	...	4.75–5.5	0.20	0.40–1.0	0.20	...
ZC63A	M16331	remainder	...	2.4–3.0	...	...	...	...	0.25–0.75	...	0.01	...	0.20	...	...	5.5–6.5	...	...	0.30
ZE41A	M16410	remainder	...	0.10	...	...	...	...	0.15	...	0.01	0.75–1.75 <sup>H</sup>	...	...	...	3.5–5.0	0.40–1.0	...	0.30
ZK51A	M16510	remainder	...	0.10	...	...	...	...	...	...	0.01	...	...	...	...	3.6–5.5	0.50–1.0	...	0.30
ZK61A	M16610	remainder	...	0.10	...	...	...	...	...	...	0.01	...	...	...	...	5.5–6.5	0.6–1.0	...	0.30

<sup>A</sup> Limits are in weight % max unless shown as a range or stated otherwise.

<sup>B</sup> ASTM alloy designations were established in accordance with Practice B951. UNS designations were established in accordance with Practice E527.

<sup>C</sup> Includes listed elements for when no specific limit is shown.

<sup>D</sup> If iron exceeds 0.005 %, the Iron to Manganese ratio shall not exceed 0.032.

<sup>E</sup> Rare earth elements are in the form of Didymium, with not less than 70 % Neodymium, and the remainder substantially Praseodymium.

<sup>F</sup> Alloy EV31A is a patented composition, suitable for elevated temperature applications. Interested parties are invited to submit information regarding the identification of alternatives to these compositions to ASTM International. Your comments will receive careful consideration at a meeting of the responsible technical committee, which you may attend. ASTM International takes no position respecting the validity of any patent rights asserted in connection with any item mentioned in this specification. Users of this specification are expressly advised that determination of the validity of any such patent rights, and the risk of infringement of such rights, are entirely their own responsibility.

<sup>G</sup> Other Rare Earths may also be present to a total maximum of 0.4 %. These Rare Earths shall principally be Cerium, Lanthanum, and Praseodymium.

<sup>H</sup> Total Rare Earths (TRE) are principally a mixture of Cerium, Lanthanum, Neodymium and Praseodymium. The Cerium content should not be less than 45% of TRE.

<sup>I</sup> Other Rare Earths shall be principally heavy rare earths, such as, Gadolinium, Dysprosium, Erbium, and Ytterbium. Other Rare Earths are derived from the Yttrium, typically 80 % Yttrium, and 20 % heavy rare earths.

<sup>J</sup> Zinc + Silver shall not exceed 0.20 % in WE43B.

melt or heat, except where this weight limit may be exceeded by a single casting. In such cases, each casting shall be considered a lot.

3.1.2 *heat treat lot, n*—for the purpose of mechanical property testing, a lot shall consist of all castings heat treated in the same furnace charge to the same temper.

3.1.3 *sand casting, n*—metal object produced by pouring molten metal into a sand mold and allowing it to solidify.

#### 4. Ordering Information

4.1 Orders for castings under this specification shall include the following information:

- 4.1.1 Applicable drawing or part number,
- 4.1.2 Quantity of each casting,
- 4.1.3 Specification number and title,
- 4.1.4 Alloy (Section 9 and Table 1),
- 4.1.5 Temper (Section 11, Table 2 and X1.2),
- 4.1.6 Whether foundry control is required (Section 8),
- 4.1.7 Whether test specimens cut from castings are required in addition to, or instead of, separately cast test specimens (Section 12 and Table X1.2),
- 4.1.8 Whether liquid penetrant inspection is required (15.2),
- 4.1.9 Whether radiographic inspection is required (15.3),
- 4.1.10 Whether pressure testing is required (15.4),
- 4.1.11 Whether source inspection is required (Section 17),

4.1.12 Whether repairs are permissible (Section 19),

4.1.13 Whether chemical analysis and mechanical property reports or certifications, or both, are required (Section 20), and

4.1.14 Whether special packaging is required for shipment (Section 22).

#### 5. Responsibility for Quality Assurance

5.1 *Responsibility for Inspection*—Unless otherwise specified in the contract or purchase order, the supplier is responsible for the performance of all inspection requirements as specified herein. Except as otherwise specified in the contract or order, the supplier may use his own or any other facilities suitable for the performance of the inspection requirements specified herein, unless disapproved by the purchaser. The purchaser reserves the right to perform any of the inspections set forth in the specification where such inspections are deemed necessary to ensure supplies and services conform to prescribed requirements.

#### 6. Material Requirements

6.1 Unless otherwise specified, only magnesium alloy ingots or producer's foundry scrap conforming to Specification B93/B93M shall be used for pouring castings. Additions of small amounts of grain refining elements and material for melt process losses are permitted.

**TABLE 2 Tensile Requirements**

NOTE 1—For purposes of determining conformance with this specification, each value for tensile strength and yield strength shall be rounded to the nearest 0.1 ksi and each value for elongation shall be rounded to the nearest 0.5 %, both in accordance with the rounding method of Practice E29.

Alloy Number		Temper <sup>A</sup>	Tensile Strength, min, ksi (MPa)	Yield Strength <sup>B</sup> (0.2 % offset), min, ksi (MPa)	Elongation in 2 in., (50.8 mm) min, %
ASTM	UNS				
AM100A	M10100	T6	35.0(241)	17.0(117)	<sup>C</sup>
AZ63A	M11630	F	26.0(179)	11.0(76)	4
		T4	34.0(234)	11.0(76)	7
		T5	26.0(179)	12.0(83)	2
		T6	34.0(234)	16.0(110)	3
AZ81A	M11810	T4	34.0(234)	11.0(76)	7
AZ91C	M11914	F	23.0(158)	11.0(76)	<sup>C</sup>
		T4	34.0(234)	11.0(76)	7
		T5	23.0(158)	12.0(83)	2
		T6	34.0(234)	16.0(110)	3
AZ91E	M11919	T6	34.0(234)	16.0(110)	3
AZ92A	M11920	F	23.0(158)	11.0(76)	<sup>C</sup>
		T4	34.0(234)	11.0(76)	6
		T5	23.0(158)	12.0(83)	<sup>C</sup>
		T6	34.0(234)	18.0(124)	1
EQ21A	M18330	T6	34.0(234)	25.0(172)	2
EV31A	M12310	T6	36.0(248)	21.0(145)	2
EZ33A	M12330	T5	20.0(138)	14.0(96)	2
K1A	M18010	F	24.0(165)	6.0(41)	14
QE22A	M18220	T6	35.0(241)	25.0(172)	2
WE43A	M18430	T6	32.0(221)	25.0(172)	2
WE43B	M18432	T6	32.0(221)	25.0(172)	2
WE54A	M18410	T6	37.0(255)	26.0(179)	2
ZC63A	M16331	T6	28.0(193)	18.0(124)	2
ZE41A	M16410	T5	29.0(200)	19.5(133)	2.5
ZK51A	M16510	T5	34.0(234)	20.0(138)	5
ZK61A	M16610	T6	40.0(276)	26.0(179)	5

<sup>A</sup> These temper designations were established in accordance with Practice B296.

<sup>B</sup> See X1.4.1.

<sup>C</sup> Not required.

6.2 Pure materials and master alloys may be used provided chemical analysis verifying conformance to **Table 1** is done prior to pouring any castings.

## 7. Manufacture

7.1 The responsibility of furnishing castings that can be laid out and machined to the finished dimensions within the permissible variations specified, as shown on the blueprints or drawings, shall rest with the supplier, except when pattern equipment is furnished by the purchaser. Sufficient stock shall be allowed for shrinkage, and where requested, for finishing; but castings of excessive weight shall not be furnished.

7.2 The castings may be subjected to such heat treatment as deemed necessary to produce material that will conform to the requirements specified. Heat treatment shall be performed on the whole of a casting, never on a part only, and shall be applied in a manner that will produce the utmost uniformity.

## 8. Foundry Control

8.1 When specified, castings shall be produced under foundry control approved by the purchaser. Foundry control shall consist of examination of the castings by radiographic or other approved methods for determining internal discontinuities until the gating, pouring, and other foundry practices have been established to produce castings meeting the quality standards set by purchaser or agreed to between the purchaser and the producer. When foundry practices have been so established, the production method shall not be significantly changed without demonstrating to the satisfaction of the purchaser that the change does not adversely affect the quality of the castings. Minor changes in pouring temperature of  $\pm 50^\circ\text{F}$  from the established nominal temperature are permissible.

## 9. Chemical Composition Requirements

9.1 *Limits*—The castings shall conform to the chemical composition limits prescribed in **Table 1**. Conformance shall be determined by analyzing samples taken when the castings are poured, or by analyzing samples taken from the finished product. If the chemical composition has been determined during the course of manufacture, sampling and analysis of the finished product shall not be necessary.

## 10. Sampling for Chemical Composition

10.1 For determination of chemical composition, one sample of each casting lot shall be taken in accordance with Practice **E88** for chemical analysis or Practice **E716** for spectrochemical analysis.

10.1.1 Samples for other methods of chemical analysis shall be suitable for the form of material being analyzed and the type of analytical method used. In case of dispute, analyses should be made by methods given in Methods **E35**.

## 11. Heat Treatment

11.1 Unless otherwise specified, heat treatment for the applicable tempers designated in **Tables 2 and X1.2** shall be in accordance with Military Specification MIL-M-6857 or Prac-

tice **B661**. Heat treatment shall be performed on the whole casting and never on a portion.

11.2 Each heat treat furnace charge shall contain at least one set of test bars of the same composition range as the castings. The satisfactory heat treatment of the furnace charge shall be determined by the results from these test bars, which must conform to the requirements of **Table 2** or **Table X1.2** where required.

## 12. Tensile Requirements

12.1 *Limits*—The tension test specimens representing the castings shall conform to the requirements of **Table 2**.

12.2 *Number of Tests*—At least one tension test specimen shall be tested from each casting lot, or fraction thereof, to represent the castings poured from the same melt. If the castings are to be heat treated, the specimens shall be heat treated with production castings of the same alloy and in the same temper as the specimens. The specimens shall then be tested to judge the ability of their corresponding melts to respond to the type of heat treatment to which the specimens were subjected.

12.2.1 *Test Specimens*—The tension test specimens shall be separately cast in the system sand mix in use and shall be cast to size in accordance with the dimensions shown in **Fig. 1** or **Fig. 2**.

12.3 When specified, the tensile strength and yield strength values of specimens cut from castings shall conform to **Table X1.2**. Elongation values shall not be less than 25 % of the values specified in **Table 2**.

12.3.1 When tensile properties of castings are to be determined, tension test specimens shall be cut from the locations designated on the drawing. If no locations are designated, specimens shall be taken from each test casting to include at least one from the thinnest and one from thickest section of the casting. At least three specimens are required.

12.3.2 The machined tension test specimen shall be the standard 0.500-in. diameter specimen or the largest smaller size specimen proportional to the standard specimen shown in **Fig. 8** of Test Methods **B557**.

12.3.3 Where a round specimen is not feasible a standard  $\frac{1}{2}$  in. wide rectangular specimen shown in **Fig. 6** of Test Methods **B557** may be used, but in no case shall its area be less than that of the sub size  $\frac{1}{4}$  in. wide specimen.

12.4 If any tension test specimen is improperly machined or shows flaws upon testing, it may be discarded and another specimen for the same heat or melt used instead. If no additional specimen is available, the supplier and the purchaser shall agree on an alternative procedure.

12.5 *Test Methods*—The tension tests shall be made in accordance with Test Methods **B557**.

12.6 *Mechanical properties at 400 to 500°F*—Alloys EQ21A, EV31A, EZ33A, QE22A, WE54A, WE43A and WE43B shall be capable of meeting the requirements shown in **Table X1.2** when tested in the following manner. Tensile test specimens shall be heated to 400 to 500°F  $\pm 5^\circ\text{F}$ , as applicable, held for 10 min before testing and loaded at this temperature at

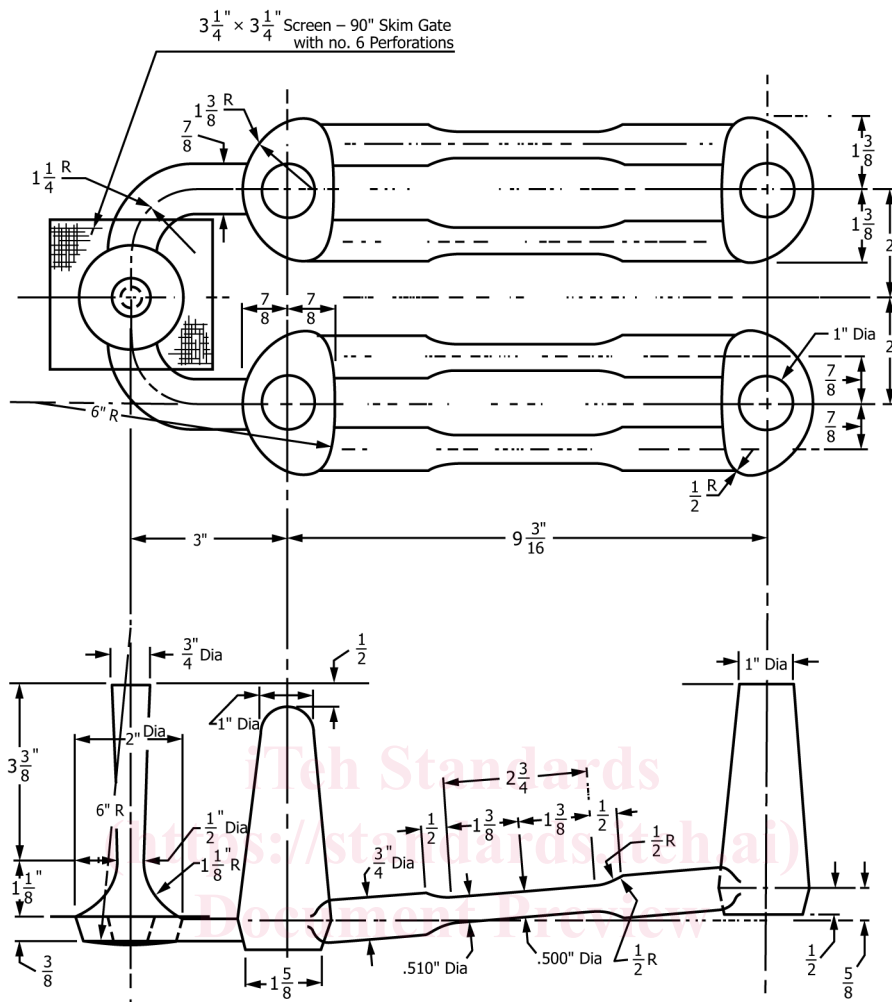

ASTM B80-15

<https://standards.iteh.ai/catalog/standards/sist/784f4d0d-44fd-4429-8e4a-f0215a3b29fd/astm-b80-15>

Metric Equivalents

in.	mm	in.	mm	in.	mm	in.	mm
0.500	12.70	7/8	22.2	1 3/8	34.9	3	76.2
0.510	12.95	1	25.4	1 5/8	41.37	3 1/4	82.5
3/8	9.5	1 1/8	28.6	2	50.8	6	152.4
1/2	12.7	1 1/4	31.8	2 3/4	69.8	9 3/16	233.4
5/8	15.9						

FIG. 1 AFS Test Bar for Sand-Cast Magnesium Alloys

a rate of 0.005 in./in./min up to the yield strength, and at a rate of 0.10 in./in./min above the yield strength.

13. Special Test Methods

13.1 When the castings have critical functional requirements, special tests to simulate the stress conditions incurred in service may be requested. The requirements and methods of these tests shall be as agreed upon between the producer and the purchaser.

14. Finish

14.1 The finished castings shall be uniform in quality, free of injurious blowholes, porosity, shrinkage, cracks, and other

discontinuities except as designated and agreed upon as acceptable by the purchaser.

14.2 Prior to shipment, castings shall be coated with a light corrosion-inhibiting oil, unless chrome pickling is required by the purchaser (see X1.5).

15. Foundry Inspection

15.1 Requirements of surface finish parting lines, and removal of gates and risers may be checked visually. It is advisable to have mutually agreed upon observational standards to represent acceptable material.

15.2 Liquid Penetrant Inspection:



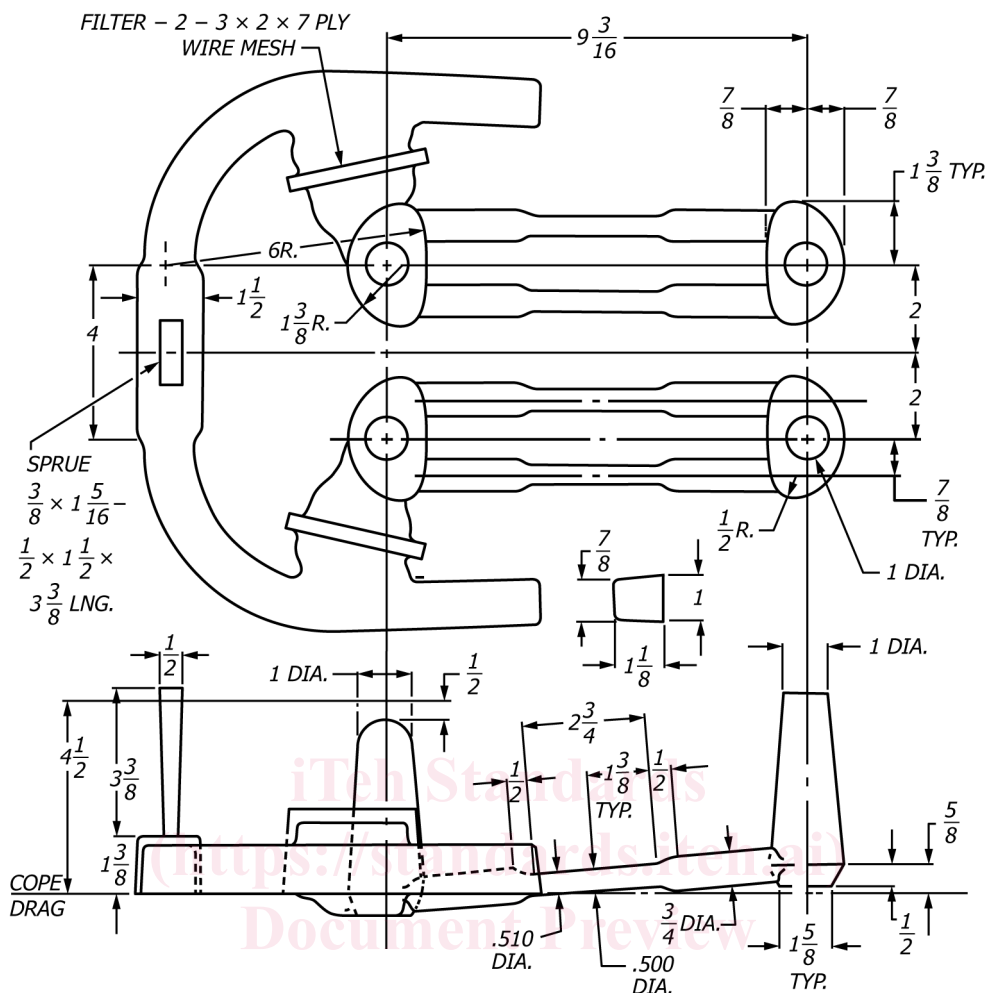

NOTE 1—This test bar mold is particularly suitable for those magnesium alloys containing Zr.

FIG. 2 Proposed Gating System for ASTM Magnesium Test Bars

<https://standards.iteh.ai/catalog/standards/sls/78414d0d-44fd-4429-8e4a-10215a3b29fd/astm-b80-15>

15.2.1 When specified liquid penetrant inspection shall be in accordance with Practice E165, and the required sensitivity shall be specified.

15.2.2 Acceptance standards for discontinuities shall be agreed upon, including size and frequency per unit area and location.

15.3 Radiographic Inspection:

15.3.1 When specified, radiographic inspection shall be in accordance with Guide E94 and Reference Radiographs E155 to determine soundness. Areas of the casting subject to

soundness requirements shall be specified by the purchaser. It is advisable to document an agreed upon radiographic technique including source parameters, film size, and orientation of the radiographs.

15.3.2 Radiographic acceptance shall be in accordance with requirements selected from Table 3. Any modifications of this table and the frequency per unit area and location should also be agreed upon between the producer and purchaser.

15.4 When specified, the castings shall be subject to hydrostatic or aerostatic pressure as required. Acceptance pressure

TABLE 3 Discontinuity-Level Requirements for Magnesium Sand Castings (Reference Radiographs E155)

Discontinuity	Grade A		Grade B			Grade C		Grade D	
	1/4	3/4	1/4	3/4	1/4	3/4	1/4	3/4	
Gas holes	none	1	1	1	2	2	5	5	
Microshrinkage (feathery)	none	1	1	1	2	2	4	3	
Microshrinkage (sponge)	none	1	1	1	2	2	4	3	
Foreign material (less dense)	none	1	1	1	2	2	4	4	
Foreign material (more dense)	none	1	1	1	2	2	4	3	
Cracks	none		none			none		none	
Cold shuts	none		none			none		none	
Surface irregularity									
Core shift									