



Designation: ~~D711~~ – ~~10 D711~~ – 10 (Reapproved 2015)

## Standard Test Method for No-Pick-Up Time of Traffic Paint<sup>1</sup>

This standard is issued under the fixed designation D711; the number immediately following the designation indicates the year of original adoption or, in the case of revision, the year of last revision. A number in parentheses indicates the year of last reapproval. A superscript epsilon ( $\epsilon$ ) indicates an editorial change since the last revision or reapproval.

*This standard has been approved for use by agencies of the U.S. Department of Defense.*

### 1. Scope

1.1 This test method covers a laboratory procedure for determining the no-pick-up time of a traffic paint. The method uses a wheel consisting of a metal cylinder with rubber O-rings. The wheel is rolled down a ramp over a freshly applied traffic paint film repeatedly until there is no transfer of paint to the rubber rings. The elapsed time from paint film application to point of no paint transfer is the no-pick-up time. Key variables to be controlled during testing are film thickness, temperature, humidity, and air flow.

1.2 The values stated in SI units are to be regarded as the standard. The values given in parentheses are for information only.

1.3 *This standard does not purport to address all of the safety concerns, if any, associated with its use. It is the responsibility of the user of this standard to establish appropriate safety and health practices and determine the applicability of regulatory limitations prior to use.*

### 2. Referenced Documents

2.1 *ASTM Standards:*<sup>2</sup>

[D823 Practices for Producing Films of Uniform Thickness of Paint, Varnish, and Related Products on Test Panels](#)

[D1212 Test Methods for Measurement of Wet Film Thickness of Organic Coatings](#)

[D1414 Test Methods for Rubber O-Rings](#)

[D2000 Classification System for Rubber Products in Automotive Applications](#)

[D4414 Practice for Measurement of Wet Film Thickness by Notch Gages](#)

[D5741 Practice for Characterizing Surface Wind Using a Wind Vane and Rotating Anemometer](#)

### 3. Significance and Use

3.1 This test method serves as a laboratory control test. Types of traffic paints that can be tested with this method are waterborne, solventborne, and some 100 % solids liquid traffic paints. This test is most commonly used with fast-dry waterborne traffic paints. If wet film thickness, temperature, and humidity are controlled within the tolerances specified herein, this method can be useful for relative testing of traffic paints and potentially for qualification of traffic paints for field application in approved specifications. For improved repeatability and meaningful comparison of paint samples being tested, consistent air flow over the paint films during testing is important. Although a no-air-flow (static) test environment is standard, the buyer and seller should agree upon the air flow conditions, whether it be static or carefully regulated air flow (see 4.6.1 and 4.6.2). No-pick-up times for fast-dry waterborne traffic paints are typically less than 10 min in a static air flow condition. Because of the many variables operative in the field application of traffic paint (for example, film thickness, air temperature, humidity, wind speed, pavement type (asphalt or concrete), film profile over pavement, pavement temperature, pavement porosity, pavement moisture content, and the presence or absence of direct sunlight during striping), a direct correlation between the results of this test and field applications is difficult to obtain. However, relative field performance can be predicted using this method if the testing protocol is adhered to.

<sup>1</sup> This test method is under the jurisdiction of ASTM Committee D01 on Paint and Related Coatings, Materials, and Applications and is the direct responsibility of Subcommittee D01.44 on Traffic Coatings.

Current edition approved Dec. 1, 2010; June 1, 2015. Published January 2011; June 2015. Originally approved in 1943. Last previous edition approved in 2004 as D711 – 89 (2004) 10. DOI: 10.1520/D0711-10; 10.1520/D0711-10R15.

<sup>2</sup> For referenced ASTM standards, visit the ASTM website, www.astm.org, or contact ASTM Customer Service at service@astm.org. For *Annual Book of ASTM Standards* volume information, refer to the standard's Document Summary page on the ASTM website.

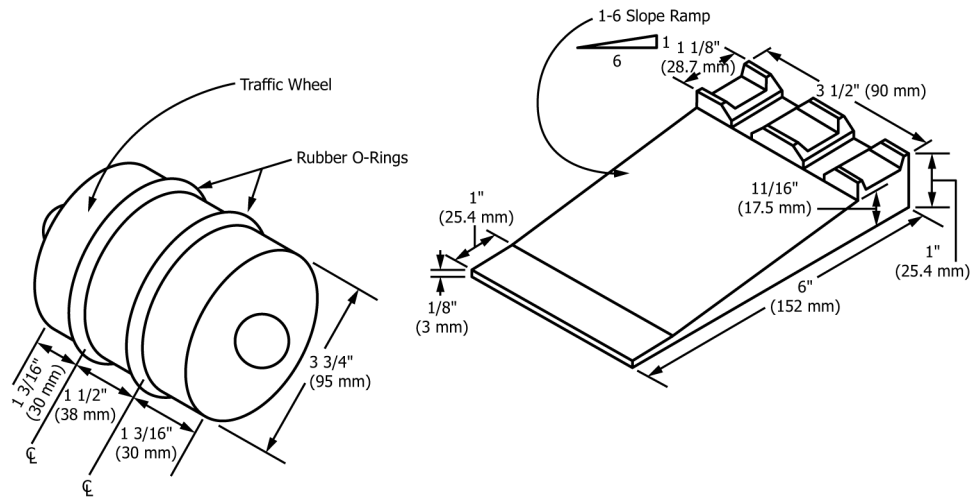
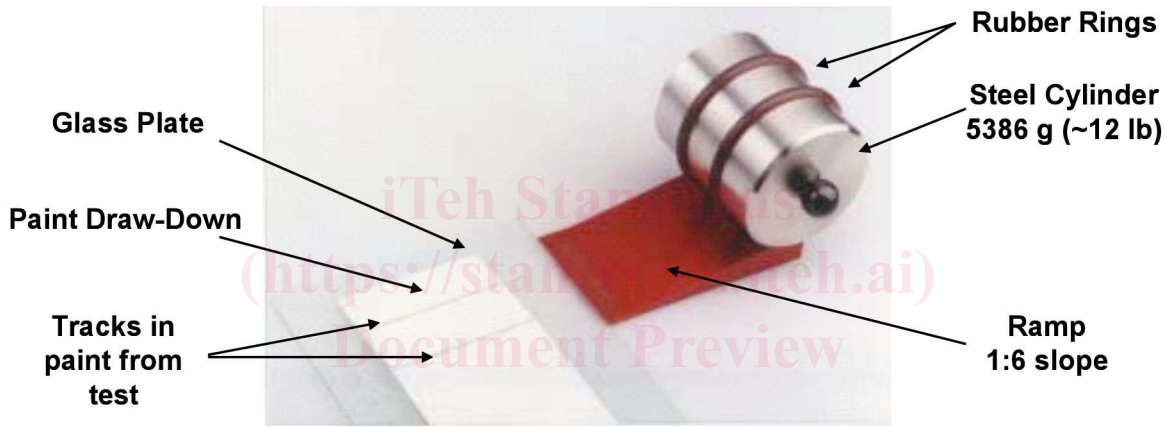

FIG. 1 Traffic Paint Drying Time Wheel and Ramp—Dual Model



Each pass of wheel over the paint film should be at least 2.5 mm (1 in.) from each end of the paint film.

FIG. 2 Picture of Apparatus and Traffic Paint Film Being Tested

4. Apparatus

4.1 The apparatus<sup>3</sup> as shown in Fig. 1 shall consist of a steel cylinder of the shape and dimensions as indicated, fitted with two replaceable O-rings and a ramp of shape and dimensions as shown.

4.2 The detailed dimensional requirements of the steel cylinder are given in Fig. 1. The total weight of the assembly complete with O-rings shall be 5386 ± 28 g (11 lb 14 oz ± 1 oz).

4.3 The detailed dimensional requirements of the ramp are shown in Fig. 1 and a picture of the apparatus with paint film being tested is shown in Fig. 2.

4.4 The replaceable O-rings shall be made of synthetic rubber or rubber-like material meeting the requirements of HK 715 of Classification D2000. Standards for O-rings and rubber products are also found in Test Methods D1414 and Classification D2000.

4.5 The dimensional requirements of the O-ring are as follows:

Outside diameter	104 mm (4 1/8 in.)
Inside diameter	85 mm (3 3/8 in.)
Cross section	9.5 mm (3/8 in.)

4.6 This test method is typically conducted in a laboratory or QC facility. In this method, values and tolerances are specified for wet film thickness, temperature, and relative humidity. Each of these factors can have a strong effect on no-pick-up time if not carefully controlled. Other things being equal, no-pick-up times are reduced (faster) with a thinner film, higher temperature, or lower relative humidity. Although tolerances for air flow are not specified, air flow also has a strong effect on no-pick-up time (See

<sup>3</sup> The sole source of supply of the apparatus known to the committee at this time that meets the requirements is available from Paul N. Gardner Co., Inc., 316 NE 1st St., Pompano Beach, FL 33060. If you are aware of alternative suppliers, please provide this information to ASTM International Headquarters. Your comments will receive careful consideration at a meeting of the responsible technical committee,<sup>1</sup> which you may attend.

Fig. 3) and is faster at higher flow rate. Even minor variations in air movement at different locations within the same laboratory can affect no-pick-up time results. The conditions and associated apparatus for controlling air flow are described in the following subsections.

4.6.1 To minimize the effects of air flow, a location for testing in the laboratory should be selected that is free of drafts with no perceptible air movement. An air flow meter (anemometer) may be helpful in detecting drafts. The use of an anemometer is detailed in Practice D5741. If drafts are detected, air flow can be minimized by using an enclosure (open front with solid top, back, and sides) around the test apparatus with approximate dimensions 61 cm wide by 46 cm deep by 46 cm tall (24 by 18 by 18 in.). The enclosure can be made of plastic or other suitable material. If an air conditioning system is used to control room temperature and humidity, the system should be set to “On” rather than “Auto” to maintain constant air movement during testing. Note that test chambers with high air turnover may give much faster no-pick-up times.

4.6.2 Upon mutual agreement by purchaser and seller, another option for regulating air flow during testing is to establish controlled air flow over the applied paint film at some fixed wind speed. One possible apparatus to control wind speed is shown in Fig. 4. This setup includes a 51 cm (20 in.) box fan, a variable transformer (voltage regulator) for fan speed control, and a precision anemometer for measurement and adjustment of the air flow. In a standard format, the glass plate for paint film drawdown is located 61 cm (24 in.) from the fan perpendicular to the air flow. A precision anemometer is located on the opposite side of the glass plate. The variable transformer is adjusted to obtain the desired wind speed over the glass plate. Once the correct wind speed is obtained, the paint film is drawn down on the glass plate and no-pick-up testing is conducted. If this approach is used, a wind speed of 3.2 to 6.4 kph (2 to 4 mph) is recommended where the slope of dry time versus wind speed is lower and in the linear region (see Fig. 3). For most consistent results, the air flow should be controlled to within  $\pm 0.16$  kph ( $\pm 0.1$  mph).

## 5. Procedure

5.1 Prepare a test stripe at least 75 mm (3 in.) in width of the paint to be tested by a mechanical spreader, or other suitable means on a clean plate glass panel at a wet film thickness of  $0.38 \pm 0.01$  mm ( $15 \pm 0.5$  mils). Use a plate glass panel approximately 100 by 200 by 3 mm (4 by 8 by  $\frac{1}{8}$  in.). Procedures for producing uniform paint films are found in Practices D823: Practice C, Motor Driven Blade Film Applicators, and Practice E, Hand Held Blade Film Applicators. Be aware that the number (in mils, microns, or mm) printed on many types of film applicator “draw-down” bars is the clearance (gap), and that the thickness of the paint applied using those applicators is often significantly less than the gap (typically 50 to 70 % of the clearance for waterborne traffic paints). Some “Bird” applicators have markings that indicate the approximate wet film thickness expected, while some “bird type” applicators have markings indicating the gap. The applied paint films should be checked for wet film thickness to ensure that they are within  $0.381 \pm 0.0127$  mm ( $15 \pm 0.5$  mils). Procedures for measurement of wet film thickness are found in Test Methods D1212 and Practice D4414. Appropriate notched or roller gauges may be used.

5.1.1 Record the time of application. Allow the panel to dry in a horizontal position under the laboratory conditions specified:  $23 \pm 2^\circ\text{C}$  ( $73.5 \pm 3.5^\circ\text{F}$ ) and  $50 \pm 5$  % relative humidity.

5.1.2 Test the paints without drop-on beads unless otherwise specified or agreed upon between the purchaser and the seller.

5.2 Butt the glass plate against the ramp. Position the wheel so that the rubber ring rolls an area of the film at least 2.54 cm (1 in.) from the edge (either end) of the test stripe. At regular intervals remove the wheel from its rest, hold against the rest as a

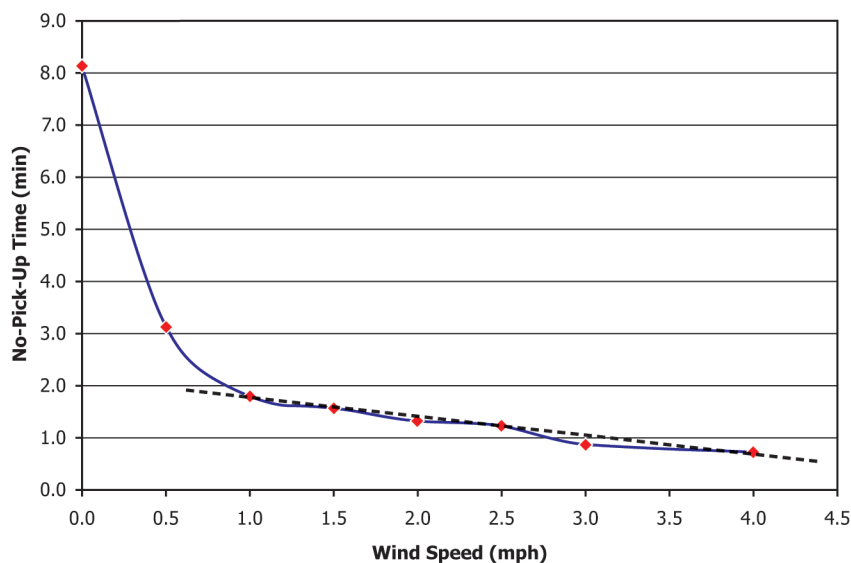

Testing was conducted on individual drawdowns of the paint at 16 mil wet film thickness,  $23^\circ\text{C}$ , and 52 % relative humidity with wind speed varied over the paint films. Wind speed was controlled by box fan, variable transformer to adjust fan speed, and precision air flow meter as shown in Fig. 4.

FIG. 3 Effect of Wind Speed on No-Pick-Up Time for a Fast-dry Traffic Paint