

---

# International Standard



# 3680

---

INTERNATIONAL ORGANIZATION FOR STANDARDIZATION • МЕЖДУНАРОДНАЯ ОРГАНИЗАЦИЯ ПО СТАНДАРТИЗАЦИИ • ORGANISATION INTERNATIONALE DE NORMALISATION

---

## Paints, varnishes, petroleum and related products — Flash/no flash test — Rapid equilibrium method

*Peintures, vernis, produits pétroliers et assimilés — Essai de point d'éclair par tout ou rien — Méthode rapide à l'équilibre*

Third edition — 1983-06-15

**ITeH STANDARD PREVIEW**  
**(standards.iteh.ai)**

[ISO 3680:1983](https://standards.iteh.ai/catalog/standards/sist/1958c183-b259-4db5-ae18-21fba2771e10/iso-3680-1983)

<https://standards.iteh.ai/catalog/standards/sist/1958c183-b259-4db5-ae18-21fba2771e10/iso-3680-1983>

---

UDC 667.612 : 536.468 : 614.835.3

Ref. No. ISO 3680-1983 (E)

**Descriptors** : paints, varnishes, petroleum products, solvents, binders (materials), tests, determination, flash point, test equipment, sampling.

## Foreword

ISO (the International Organization for Standardization) is a worldwide federation of national standards bodies (ISO member bodies). The work of developing International Standards is carried out through ISO technical committees. Every member body interested in a subject for which a technical committee has been authorized has the right to be represented on that committee. International organizations, governmental and non-governmental, in liaison with ISO, also take part in the work.

Draft International Standards adopted by the technical committees are circulated to the member bodies for approval before their acceptance as International Standards by the ISO Council.

International Standard ISO 3680 was developed jointly by Technical Committees ISO/TC 35, *Paints and varnishes*, and ISO/TC 28, *Petroleum products and lubricants*. This third edition was submitted directly to the ISO Council, in accordance with clause 6.11.2 of part 1 of the Directives for the technical work of ISO. It cancels and replaces the second edition (i.e. ISO 3680-1981), which had been approved by the member bodies of the following countries : <https://standards.iteh.ai/catalog/standards/sist/1958c183-b259-4db5-ae18-21fa2771e10/iso-3680-1983>

Australia	Hungary	Poland
Austria	India	Romania
Brazil	Ireland	South Africa, Rep. of
Canada	Israel	Sweden
Chile	Italy	Switzerland
China	Kenya	United Kingdom
Egypt, Arab Rep. of	Korea, Rep. of	USA
Germany, F. R.	Netherlands	USSR

The member body of the following country had expressed disapproval of the document on technical grounds :

France

# Paints, varnishes, petroleum and related products — Flash/no flash test — Rapid equilibrium method

## 0 Introduction

This International Standard sets out one of two methods for carrying out the flash/no flash test for paints, varnishes, petroleum and related products, and it should be read in conjunction with ISO 1516 when selecting a method.

This method of test does not determine the flashpoint of the product under test, but merely its behaviour at the selected equilibrium temperature as may be required to comply with laws or regulations relating to the storage, transport and use of flammable products. For this purpose it is unnecessary to determine the exact flashpoint but it is necessary to determine whether or not flashing occurs at a single given temperature.

In ISO 1516, a similar determination is specified, using cups as described in various national standards. The apparatus specified in this International Standard enables a similar result to be determined using a more rapid procedure and with a smaller test portion (2 ml) of material than that given in ISO 1516. Because of the small volume of test portion taken, thermal equilibrium is rapidly reached. In addition, the apparatus can be made portable to the extent of being suitable for on-site testing as well as for normal use in laboratories. Collaborative work<sup>1)</sup> has shown that results obtained by these procedures are comparable.

### NOTES

1) The determination of the exact flashpoint using the same equipment is given in ISO 3679.

2) The difference between this edition and the second is that the tolerance on the position of the nozzle (4.1) has been diminished from 1,0 to 0,1 mm and more exactly specified.

## 1 Scope and field of application

This International Standard specifies a method to determine if a flammable material such as a paint, varnish, paint binder, sol-

vent, petroleum or a related product, when maintained at a selected equilibrium temperature between 0 and 110 °C and under the conditions of test, gives off sufficient flammable vapour at this temperature to cause ignition on the application of an external source of flame applied in a standard manner.

## 2 References

ISO 1512, *Paints and varnishes — Sampling.*

ISO 1513, *Paints and varnishes — Examination and preparation of samples for testing.*

ISO 1516, *Paints, varnishes, petroleum and related products — Flash/no flash test — Closed cup equilibrium method.*

ISO 3170, *Petroleum products — Liquid hydrocarbons — Manual sampling.*

ISO 3171, *Petroleum products — Liquid hydrocarbons — Automatic pipeline sampling.*

ISO 3679, *Paints, varnishes, petroleum and related products — Determination of flashpoint — Rapid equilibrium method.*<sup>2)</sup>

## 3 Principle

The test portion is heated in the specified apparatus. The ignition trial is carried out after the test portion has been maintained under equilibrium conditions for 60 s at the selected equilibrium temperature. This procedure ensures that the air/vapour space above the test portion has attained the saturation concentration of flammable vapour before the ignition trial is performed. The test report records whether the test portion at this temperature flashed or did not flash.

1) BELL, L.H. *J. Inst. Petrol.* **57** (556) July 1971.

2) At present at the stage of draft. (Revision of ISO 3679-1976.)

## 4 Apparatus

**4.1 Flashpoint tester**, consisting of a block of aluminium alloy or other suitable corrosion-resistant metal of high thermal conductivity. The block has a cylindrical depression or test portion well, of depth approximately 10 mm and diameter approximately 50 mm, over which is fitted a cover. A thermometer is embedded in the block. A plan diagram is given in figure 1 and the essential dimensions are given in figures 2 to 5. The cover is fitted with an opening slide and a device capable of inserting an ignition flame (diameter  $3,5 \pm 0,5$  mm) into the well when the slide is open. When inserted, the extremity of the nozzle of the ignition device shall just intersect the plane of the underside of the cover; a tolerance of  $\pm 0,1$  mm shall be permitted. The cover is also provided with an orifice extending into the well for insertion of the test portion and with a suitable clamping device for securing the cover tightly to the metal block so that the three openings in the cover are within the diameter of the well. It is important that when the slide is in the open position the two openings in the slide coincide exactly with the two corresponding openings in the cover.

**4.2 Thermometer**, of appropriate range and dimensions which, when embedded in the metal block as specified, measures the temperature of the block within a maximum error of  $0,5$  °C. A thermometer having a graduation at each  $0,5$  °C is recommended. When required, the accuracy of the thermometer shall be checked against a reference standard by an authorized laboratory, using the stipulated immersion.

**4.3 Heating device**, fitted with a temperature controller such that the temperature of the metal block can be maintained within  $\pm 0,2$  °C of the required temperature. A signal light is necessary to indicate when heating is on. If the apparatus is intended to be portable, the heating device shall be electrical and shall be part of the complete apparatus.

**4.4 Means of cooling the well** : Ice, solid carbon dioxide (CO<sub>2</sub>), or a Peltier or other suitable cooling device.

**4.5 Syringe**, capable of delivering 2 ml to an accuracy of  $\pm 0,1$  ml or, for use with highly viscous products, **micropipette** or **spatula** (see the note in 7.1.5).

**4.6 Fuel source** for the ignition device : Normally butane fuel, but coal gas or natural gas are satisfactory alternatives.

**4.7 Suitable timing device.**

## 5 Sampling and sample treatment

**5.1** Take a representative sample of the product to be tested using the appropriate sampling procedure for the product concerned. References to sampling procedures for various products are given in the annex.

The sample shall be kept in an airtight container until it is to be tested. The ullage, i.e. the air-space above the contents of the container, shall not be more than 10 % of the total capacity of the container.

NOTE – Samples should not be stored in plastics (polyethylene, polypropylene, etc.) bottles since volatile material may diffuse through the walls of the bottle.

**5.2** Because of the possibility of loss of volatile constituents, the sample container shall be cooled to at least  $10$  °C below the selected equilibrium temperature, before opening it to remove the test portion, except when method 2 (see 7.2) is used. In this case, the sample shall be cooled to  $3$  to  $5$  °C below the specified test temperature. The sample shall receive only the minimum mixing treatment to ensure uniformity. After removal of the test portion, the sample container shall immediately be tightly closed to ensure that loss of volatile flammable components from the container is minimized. If this is not carried out, the product sample shall be deemed unsuitable for further testing.

## 6 Preparation of apparatus

Place the test apparatus in a position where it is not exposed to draughts, and preferably in subdued light.

## 7 Procedure

### 7.1 Method 1 : Flash/no flash test when the selected equilibrium temperature is between ambient temperature and $110$ °C

NOTE 1 – When the selected equilibrium temperature is close to ambient, it may be more appropriate to use method 2.

**7.1.1** Ensure that the well and cover/slide are clean and free from contamination, using a paper tissue if necessary. Close the cover and ensure that the slide is in the closed position.

**7.1.2** Turn on the heating device (4.3). When the thermometer (4.2) reads approximately  $3$  °C below the selected equilibrium temperature of the product to be tested, slowly adjust the controller of the heating device to the point at which the signal light is just extinguished. Allow the temperature of the well to stabilize, as indicated by the signal light cycling ON/OFF.

**7.1.3** The selected equilibrium temperature shall be corrected for variation from an atmospheric pressure of  $101,3$  kPa ( $1013$  mbar or  $760$  mmHg), by raising the temperature for a higher pressure or lowering it for a lower pressure at the rate of  $1$  °C for each  $4$  kPa ( $40$  mbar or  $30$  mmHg) difference.

NOTE – Although this correction is only strictly valid within the atmospheric pressure range  $98,0$  to  $104,7$  kPa, for pressures outside this range the error is sufficiently small to be ignored.

**7.1.4** Further slight adjustment of the controller shall then be made to obtain the precise temperature by bringing the temperature of the block to the corrected selected equilibrium temperature.

**7.1.5** Ensure that the syringe (4.5) is clean and dry. Charge the syringe with 2 ml of the cooled sample (5.2) and transfer the syringe to the filling orifice, taking care not to lose any of

the contents. Quickly discharge the test portion into the well, remove the syringe, and immediately start the timing device (4.7).

NOTE — If the viscosity of the product under test is so high as to prevent discharge through the orifice, a test portion of 2 to 3 ml may be transferred with a micro-pipette or a spatula into the well while the cover is open.

**7.1.6** Open the gas control valve and light the pilot and test flames. Adjust the test flame size to  $3,5 \pm 0,5$  mm diameter.

**7.1.7** When 60 s have elapsed, by which time the test portion is deemed to have reached the test temperature, perform the ignition trial by opening the slide, inserting and removing the jet, and closing the slide again over a period of  $2,5 \pm 0,5$  s. Watch for a flash between opening and closing the slide.

**7.1.8** Record whether a flash has occurred.

#### NOTES

1 When the vapour mixture under test is near the flashpoint, application of the ignition flame may give rise to a halo; however, the product is only deemed to have flashed if a comparatively large blue flame appears and propagates itself over the surface of the liquid. In case of doubt, the test shall be repeated with a fresh test portion and if the doubt is unresolved by the second test, the product shall be regarded as having flashed.

2 If a continuous luminous flame burns in the orifice when the slide is opened and the ignition flame is introduced, then the flashpoint lies considerably below the selected equilibrium temperature.

**7.1.9** Close the gas control valve and clean the apparatus.

**7.1.10** Carry out a duplicate test following the procedure from 7.1.1 and using a fresh test portion. If either test results in a flash, the product shall be considered as having flashed at the selected equilibrium temperature.

## 7.2 Method 2 — Flash/no flash test when the selected equilibrium temperature is below ambient temperature

**7.2.1** Ensure that the sample and its container are at 3 to 5 °C below the selected equilibrium temperature.

**7.2.2** Cool the well (see 4.4) until its temperature is 3 to 5 °C below the selected equilibrium temperature (see 7.1.3). Ensure that the well and cover/slide are clean and dry, and free from any residue of carbon dioxide. Close the cover and ensure that the slide is in the closed position.

**7.2.3** Ensure that the syringe (4.5) is clean and dry. Charge the syringe with 2 ml of the cooled sample (5.2) and transfer the syringe to the filling orifice, taking care not to lose any of the contents. Quickly discharge the test portion into the well (see the note in 7.1.5) and remove the syringe.

**7.2.4** Open the gas control valve and light the pilot and test flames. Adjust the test flame size to  $3,5 \pm 0,5$  mm diameter.

**7.2.5** When the temperature of the well reaches the corrected selected equilibrium temperature (see 7.1.3), perform the ignition trial by opening the slide, inserting and removing the jet, and closing the slide again over a period of  $2,5 \pm 0,5$  s. Watch for a flash between opening and closing the slide (see notes in 7.1.8).

**7.2.6** Record whether a flash has occurred.

**7.2.7** Close the gas control valve and clean the apparatus.

**7.2.8** Carry out a duplicate test following the procedure from 7.2.1 and using a fresh test portion. If either test results in a flash, the product shall be considered as having flashed at the selected equilibrium temperature.

## 8 Precision

Precision data are not quoted for this method. However, when selecting a temperature to be specified for this method, an indication of the repeatability and reproducibility of results close to a selected equilibrium temperature is obtained from the precision data given in ISO 3679, which is a similar method used for the determination of the flash point temperature.

## 9 Test report

The test report shall include at least the following information :

- the type and identification of the product tested;
- a reference to this International Standard (ISO 3680) and the method used : method 1 or 2 (as appropriate);
- the selected equilibrium temperature used, in degrees Celsius, the correction applied, the atmospheric pressure and whether the product flashed or did not flash;
- any deviation, by agreement or otherwise, from the test procedure specified;
- the date of the test.

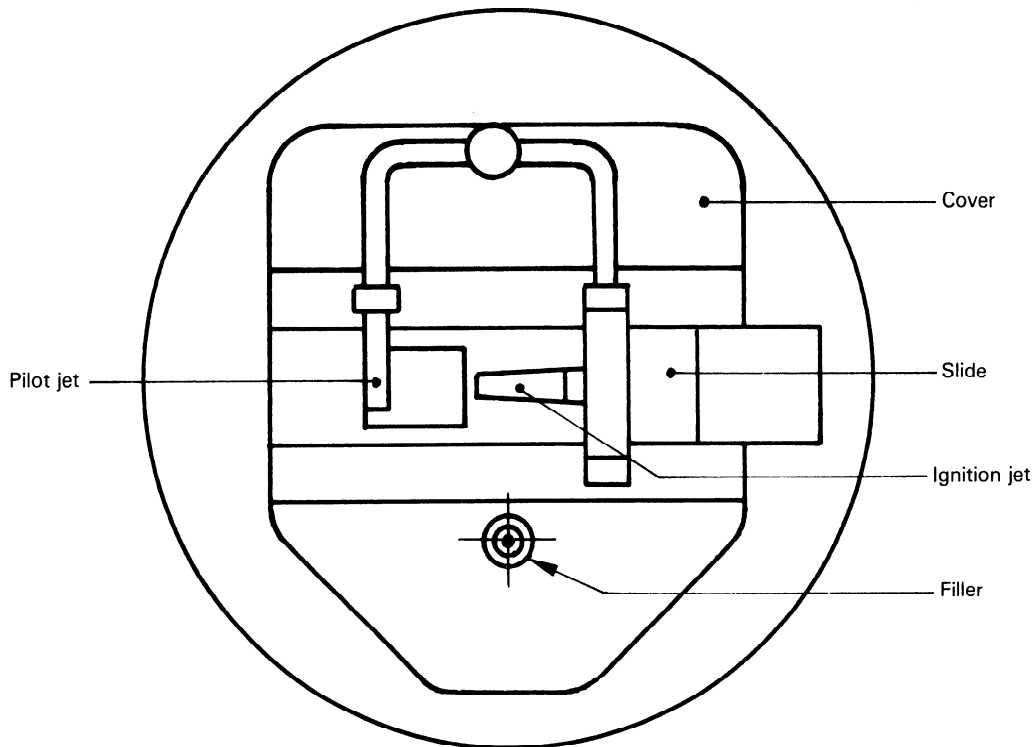

iTeh STANDARD PREVIEW

Figure 1 — Plan diagram of flashpoint tester

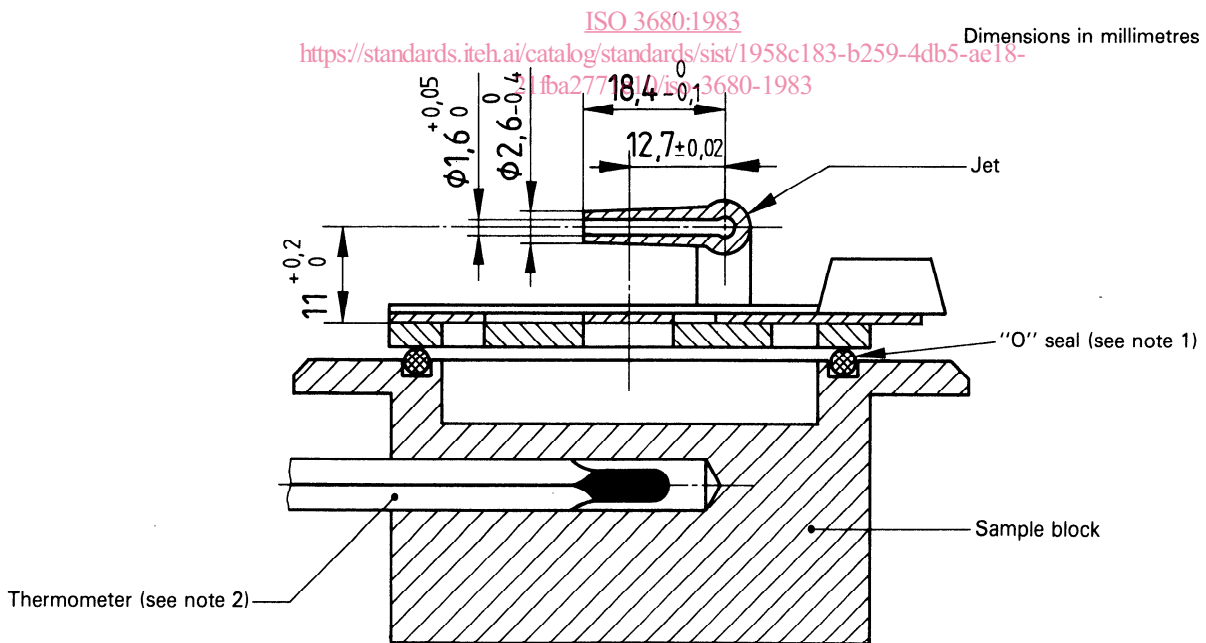
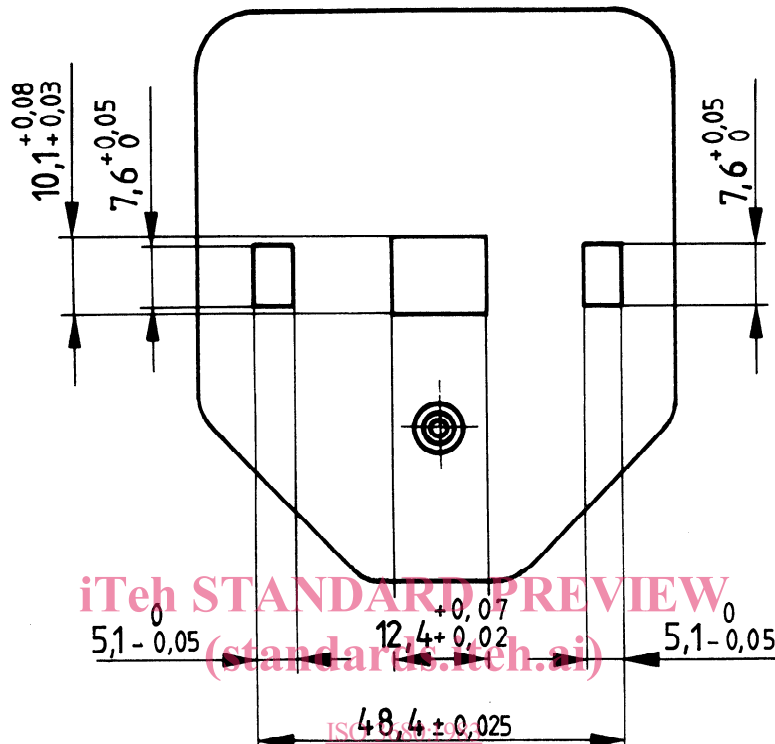

Figure 2 — Section of block through jet

- NOTES
- 1 The "O" seal or gasket which provides a tight seal when the cover is shut shall be made of a heat-resistant material to withstand temperatures up to 150 °C.
  - 2 When in position, the thermometer bulb shall be surrounded with a suitable thermal conducting thermoplastic compound.
  - 3 The slide should be fitted with a spring to ensure that it stays in the fully closed position when shut.

Dimensions in millimetres



<https://standards.iteh.ai/catalog/standards/sist/1958c183-b259-4db5-ae18-21fba2771e10/iso-3680-1983>

Figure 3 — Cover

(brass or other suitable metal, approximately 2 mm thick)

Dimensions in millimetres

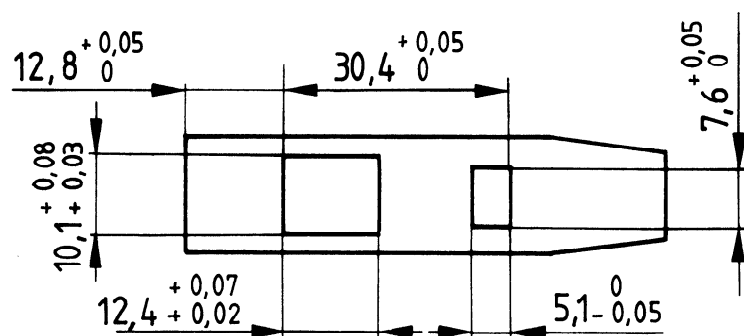
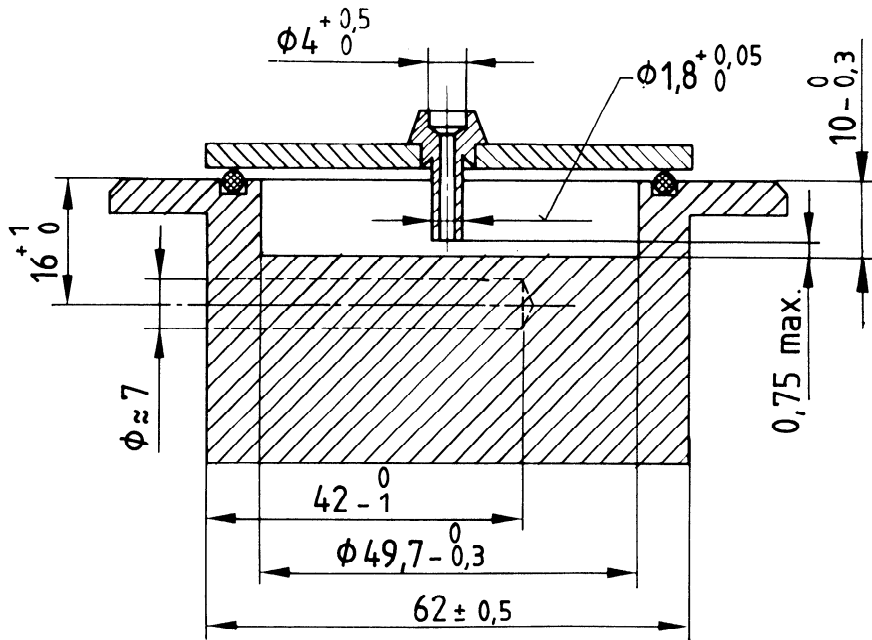

Figure 4 — Slide

(stainless steel or other suitable metal, approximately 1,2 mm thick)



Dimensions in millimetres



**iTeh STANDARD PREVIEW**  
 Figure 5 – Section of block through filler hole  
 (standards.iteh.ai)

ISO 3680:1983

<https://standards.iteh.ai/catalog/standards/sist/1958c183-b259-4db5-ae18-21fba2771e10/iso-3680-1983>

## Annex

### Sampling procedures

#### A.1 Paints, varnishes and related products

Take a representative sample of the product to be tested as specified in ISO 1512 and examine and prepare it for testing as specified in ISO 1513. In addition observe the precautions of 5.2, as appropriate.

#### A.2 Petroleum and related products

Take a representative sample of the product to be tested as specified in ISO 3170 or ISO 3171, as appropriate. In addition observe the precautions of 5.2, as appropriate.